

California High-Speed Train Project



TECHNICAL MEMORANDUM

CHSTP CADD Guidelines TM 1.1.5

Prepared by: Signed document on file 01 March 12
Rebecca Mincio _____ Date

Checked by: Signed document on file 01 March 12
John Chirco, PE _____ Date

Approved by: Signed document on file 21 June 12
Ken Jong, PE, Engineering Manager _____ Date

Released by: Signed document on file 18 Jul 12
Hans Van Winkle, Program Director _____ Date

Revision	Date	Description
0	03 Apr 07	Initial Release
1	10 Oct 08	Revised for Preliminary Design
2	05 Oct 09	Revised for Caltrans Standards Updates
3	01 Mar 12	Revised for 30% Design and Procurement

Note: Signatures apply for the latest technical memorandum revision as noted above.

Prepared by **PARSONS
BRINCKERHOFF**

for the California High-Speed Rail Authority

This document has been prepared by **Parsons Brinckerhoff** for the California High-Speed Rail Authority and for application to the California High-Speed Train Project. Any use of this document for purposes other than this Project, or the specific portion of the Project stated in the document, shall be at the sole risk of the user, and without liability to PB for any losses or injuries arising from such use.



TABLE OF CONTENTS

ABSTRACT 1

1.0 INTRODUCTION..... 2

1.1 PURPOSE OF GUIDELINES DOCUMENT 2

1.2 MINIMUM SYSTEM REQUIREMENTS 2

1.2.1 SHEET PRODUCTION 2

1.2.2 DESIGN FILES 2

1.3 GENERAL INFORMATION 2

1.3.1 PROJECTSOLVE DOCUMENT MANAGEMENT SYSTEM..... 2

1.3.2 PROJECTWISE DOCUMENT MANAGEMENT SYSTEM..... 3

1.3.3 DEFINITION OF TERMS..... 3

1.3.4 ACRONYMS..... 4

1.3.5 UNITS..... 4

1.3.6 HARD COPY DELIVERABLES 5

1.3.7 ELECTRONIC “SOFT” COPY DELIVERABLES 5

1.3.8 CADD RESOURCE LIBRARY 6

1.3.9 CHSTP CADD INBOX 6

1.3.10 CHSTP CADD CONTACTS 6

1.3.11 CHSTP CADD STANDARDS REQUEST FORM 6

2.0 CADD FILE OVERVIEW..... 7

2.1 CADD FILES 7

2.2 MASTER FILES 7

2.3 SHEET FILES..... 7

2.4 NESTING FILES..... 7

2.5 WORKING FILES 7

2.6 FILE MANAGEMENT AND DIRECTORY STRUCTURE..... 8

2.7 PROJECT COORDINATE SYSTEM 9

2.8 PROJECT VERTICAL DATUM..... 9

2.9 PROJECT WORKING UNITS 9

2.10 PROJECT SEED FILES 9

2.11 PROJECT RESOURCE FILES 11

3.0 CADD FILE NAMING CONVENTION 12

3.1 MASTER FILES 12

3.1.1 MASTER FILE NAMING CONVENTION..... 12



3.1.2	MASTER FILE CODE (ONE CHARACTER).....	13
3.1.3	GEOGRAPHIC LOCATION SEGMENT CODE (TWO CHARACTERS) / SUBDIVISION PACKAGE CODE (TWO CHARACTERS).....	13
3.1.4	DISCIPLINE CODE (TWO CHARACTERS).....	15
3.1.5	MAJOR DESCRIPTION CODES (FOUR CHARACTERS).....	15
3.1.6	USER DEFINED DESCRIPTION CODES (FOUR CHARACTERS).....	15
3.2	LOGICAL NAMES	16
3.3	WORKING FILES	16
3.4	SHEET FILES.....	17
3.4.1	SHEET FILE NAMING CONVENTION	17
3.4.2	LEVEL 1 & 2 DISCIPLINE CODE	17
3.4.3	SHEET TYPE DESIGNATORS.....	18
3.4.4	SEQUENCE NUMBER	18
3.4.5	USER DEFINED DESIGNATOR	18
3.4.6	DRAWING NUMBER	18
3.5	PLAN SHEET FILES	19
3.5.1	NESTING FILES.....	19
3.5.2	BORDERS	19
3.5.3	PLAN SHEET DRAWING SCALES.....	20
3.5.4	ELEVATION, SECTION AND DETAIL SHEET FILES	20
3.5.5	MIXING DRAWING SCALES.....	21
4.0	LEVELS AND SYMBOLOGY	22
4.1	GENERAL	22
4.2	DESIGN FILE LIBRARIES (DGNLIB).....	22
4.3	FONTS AND TEXT.....	22
4.3.1	TEXT PLACEMENT GUIDELINES	23
4.4	DIMENSIONING	23
4.5	LINE STYLES.....	24
5.0	PLOTTING AND PEN TABLES	25
5.1	PLOTTING	25
5.2	PLOT DRIVERS	25
5.3	PEN TABLE	25
	Appendix A – CHSTP CADD STANDARDS REQUEST FORM.....	26
	Appendix B – BORDERS	27
	Appendix C – LEVEL 1 & LEVEL 2 DISCIPLINE DESIGNATOR	30
	Appendix D – MAJOR DESCRIPTION CODES	36
	Appendix E – SHEET TYPE DESIGNATORS.....	45
	Appendix F – DGNLIB.....	46



Appendix G – LINSTYLE RESOURCE FILE 88
Appendix H – CALIFORNIA COORDINATE SYSTEM (CCS83)..... 94



ABSTRACT

This document presents guidelines for the development of Computer Aided Design and Drafting (CADD) drawings for the design of the California High-Speed Train Project (CHSTP). These guidelines are intended to provide a means to maintain consistency in the presentation of contract drawings and to organize the electronic database so that it can be easily accessed across the project disciplines and geographic regions and utilized throughout the duration of the project.

The intended audience for this document is the various regional design teams and design builders preparation CADD drawings for the CHSTP. Adherence to the CADD Guidelines will produce a consistent set of drawings that are organized and contain sufficient information to clearly convey the design intent. The CADD Guidelines shall be followed by all CADD users to assure a unified set of documents is presented to the client.

The document includes guidance on the drawing standards, software platforms, file management and file types.

Guidelines for the development and maintenance of electronic files and information are also included in this document. Concurrent with the release of this guidelines document, drawing files containing the CHSTP drawing border will be made available for use by designers in preparing project drawings.



1.0 INTRODUCTION

1.1 PURPOSE OF GUIDELINES DOCUMENT

The purpose of this guidelines document is to establish uniform policies and procedures for the Design, Drafting, and Management of electronic files and information for the California High-Speed Train Project (CHSTP) drawing delivery process.

The guidelines document presents the methods and standards to be used to develop CADD drawings for the CHSTP and are intended to provide a means to maintain consistency and uniformity in the presentation of contract drawings and to organize the electronic database in a manner that can be easily accessed and utilized across the project disciplines and geographic regions and utilized throughout the duration of the project.

The guidelines are to be adhered to throughout the project development process in order to provide a consistent set of organized drawings that contain sufficient information to clearly convey the design intent.

Special situations that require a deviation from the CADD guidelines must be presented to the CHSTP CADD manager for suggestions and solutions via the CHSTP CADD Standards request form discussed in Appendix A of this manual.

1.2 MINIMUM SYSTEM REQUIREMENTS

1.2.1 Sheet Production

The CHSTP standard CADD production platform shall be Bentley's MicroStation V8i (Select Series 1 or higher). Information regarding the system requirements for this production platform can be found on the Bentley website, link shown below:

http://ftp2.bentley.com/dist/collateral/docs/microstation/microstation_product_data_sheet.pdf

1.2.2 Design Files

The CHSTP standard vertical design platform shall be Bentley's Inroads Suite V8i. Information regarding the system requirements for this design platform can be found on the Bentley website, link shown below:

<http://www.bentley.com/en-US/Products/InRoads+Suite/Technical-Requirements.htm>

1.3 GENERAL INFORMATION

1.3.1 ProjectSolve Document Management System

The CHSTP management team has established ProjectSolve as its primary document management system. Its' purpose includes centralizing and maintaining all necessary documents between the management and design teams. Links to folders and files managed within ProjectSolve can be found throughout this document.

A formal request is required for any/all parties that need access to the CHSTP ProjectSolve site. The workflow shown has been established to streamline the process of granting new users permission to the site.



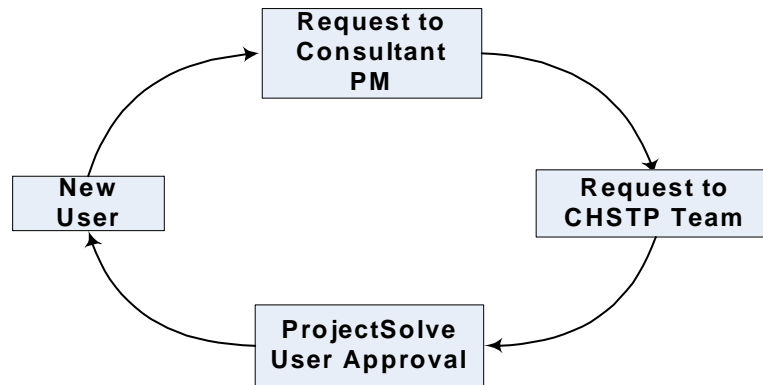

1.3.2 ProjectWise Document Management System

The CHSTP management team has also established Bentley's ProjectWise V8i (Select Series 1 or higher) as its primary electronic (DGN file) design drawing management system for Preliminary Design for Procurement and procurement drawing submittals.

1.3.3 Definition of Terms

The following technical terms are used in this document and have specific connotations with regard to the CHSTP:

As-Built Drawings	Construction Drawings modified to reflect design changes and actual conditions of construction, conformed from field and design changes directly from the Ready for Construction (RFC) drawings
Contract drawings	Drawings files that are specific to the project and contract. Contract drawings include preliminary design drawings and construction drawings
Construction Drawings	Drawings furnished by the contractor representing the post preliminary design project delivery, from final design through completion of construction. Construction drawings include Final Design drawings, Ready for Construction (RFC) drawings as As-Built drawings
Contract Number	The number assigned to an individual design or construction project
Directive Drawings	Directive Drawings provide mandatory design criteria in a graphical format that the Contractor shall follow and apply to ensure consistency during design for system-wide elements and features
Drawing Number	Number found in the titleblock assigned to an preliminary, construction, standard or directive drawings
Preliminary Engineering for Procurement	Preliminary engineering that demonstrate technical feasibility and constructability for procurement
Ready for Construction Drawings (RFC)	Construction drawings designed to 100% that are ready and used during construction. They are the basis for the as-built drawings



Regional Consultant	The consultant selected by the Authority to be responsible for the overall preliminary design of the project
Resolution	The 'worst-case' accuracy for the design environment that occurs at the very outer limits of the working area/plane/volume
Seed File	A CADD template file that contains settings such as the project global origin and working units and does not contain design elements
Standard Drawings	Standard project elements for general use in the construction of the California High-Speed Train system, as determined applicable by the Contractor
Title Block	The title block in these guidelines is defined as the lower portion of the drawing containing information such as drawing title, signature blocks, project logos, et al

1.3.4 Acronyms

CADD	Computer Aided Design and Drafting
CC	Carbon Copy
CCS	California Coordinate System
Caltrans	California Department of Transportation
CHSTP	California High-Speed Train Project
DGN	MicroStation V8i cad file
EMT	Engineering Management Team
NIST	National Institute of Standards and Technology
PDF	Portable Document Format
PMT	Program Management Team

1.3.5 Units

The California High-Speed Train Project is based on U.S. Customary Units and defined by the National Institute of Standards and Technology (NIST). U.S. Customary Units are officially used in the United States, and are also known in the US as "English" or "Imperial" units. In order to avoid confusion, all formal references to units of measure should be made in terms of U.S. Customary Units. See the CHSTP Plans Preparation Manual for additional information regarding units.



1.3.6 Hard Copy Deliverables

Hard Copy files shall be available for transmittal in the following format:

- Black and white on recycled white copy paper for half size copies. Full size sets printed on 24lb bond plotter paper
- Each paper copy submittal shall be accompanied by a PDF submittal for each of the plan set packages.

Plot size is dependent on the submittal and shall be prepared as shown in the below chart:

Drawing submittal	PDF Half (11x17)	PDF Full (22x34)
15% Record Set	X	
Preliminary Design for Procurement	X	
Construction Design Drawings	X	X
Ready for Construction (RFC)	X	X
As-Built	X	X

1.3.7 Electronic “Soft” Copy Deliverables

Electronic CADD files deliverables shall be available for transmittal with the following requirements:

- MicroStation V8i design files (DGN) format
- One model per DGN file (external models or models within the same DGN)

DGN requirements are dependent on the submittal and shall be prepared as shown in the below chart:

Drawing submittal	DGNs merged	DGNs unmerged
15% Record Set		X
Preliminary Design for Procurement		X
Construction Design Drawings		X
Ready for Construction (RFC)	X	
As-Built	X	



1.3.8 CADD Resource Library

The CHSTP PMT utilizes ProjectSolve as the central repository for all CADD resources files. Files residing in the CADD resources shall be, but not limited to, the list shown below:

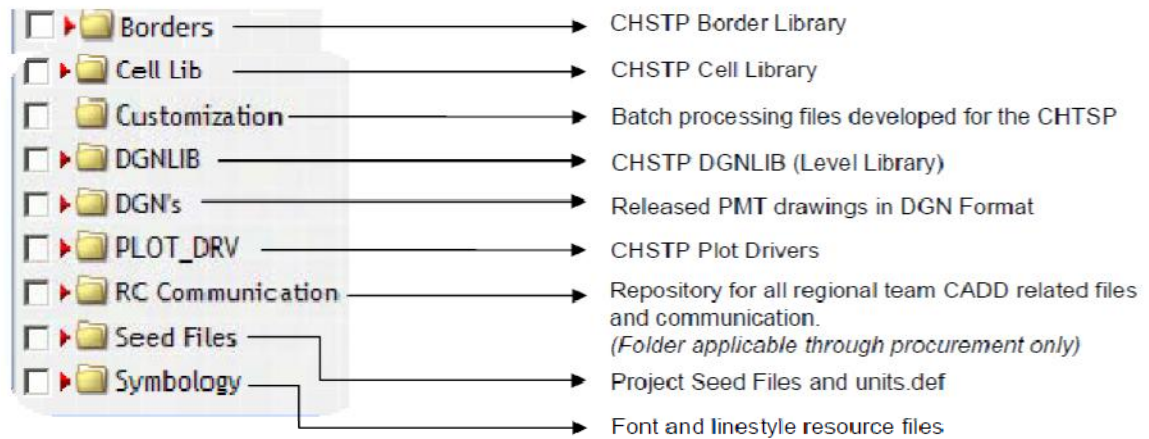

Link to CADD Resources Folder:

https://ww3.projectsolve2.com/eRoom/SFOF7/Engineering/0_48e9b

1.3.9 CHSTP CADD Inbox

The PMT has established a dedicated ProjectSolve Inbox to house all CADD related correspondence. It is required, for all CADD related correspondence transmitted to the PMT, to CC the CHSTP CADD Inbox.

Email Address:

CHSTPCAD@projectsolvemail.com

1.3.10 CHSTP CADD Contacts

It is vital throughout the duration of the CHSTP Project to maintain a primary CADD Contact list. To date, the list includes names, emails and phone numbers for the EMT CADD Manager, EMT CADD Lead and all design consultants CADD leads. It shall be maintained throughout the lifecycle of the project, from preliminary design thru construction. Any revisions to the CADD contact list must be transmitted to the management team to ensure the contact list remains current.

Link to CHSTP CADD Contacts List:

https://WW3.projectsolve2.com/eRoom/SFOF7/Engineering/0_c3556

1.3.11 CHSTP CADD Standards Request Form

The CHSTP CADD Standard Request form has been established to maintain and certify any variances in the CADD Standard throughout the life cycle of the project.

A copy of the CHSTP CADD Standards Request can be found in Appendix A of this manual. Users must use the link below to the official PDF Form for all CADD standard variance request. As stated above in Section 1.3.10, all email requests shall CC the CHSTP CADD Inbox in addition to emailing the CADD manager:

Link to CHSTP CADD Standards Request Form:

https://WW3.projectsolve2.com/eRoom/SFOF7/Engineering/0_c3557



2.0 CADD FILE OVERVIEW

2.1 CADD FILES

The Design efforts will result in the creation of numerous CADD files, including master files, sheet files, nested files and working files.

2.2 MASTER FILES

Master files are intended as overlays to other CADD files and are used to share design data between disciplines and designers. Typically master files include survey, mapping topography, utilities, and track alignment.

See Section 3.1.1 for Master File Naming Convention

2.3 SHEET FILES

Sheet files will contain only sheet dependent information such as title block information, north arrow, bar scales, dimensions, and notes. Master files are attached to the sheet files and clipped to display design information particular to that sheet. Information viewed in the sheet can be manipulated with level controls. Details, sections, and elevations will be drawn to a scale as required to convey the necessary design information and design intent. Sheet files incorporate necessary design information to create a design discipline drawing for inclusion in a specific deliverable plan set. Plotting for drawings shall be done from the sheet files. Saved view titled "PLOT" shall be created for each sheet view.

See Section 3.4.1 for Sheet File Naming Convention.

See Plans Preparation Manual for additional information regarding sheet file generation

2.4 NESTING FILES

Nesting files are master files that are attached to the sheet files using the "live nesting" feature. A nesting file is a compilation of master files that are displayed with the settings and level structure that are to be displayed in the sheet file. When the nesting file is attached to the sheet file with "live nesting" turned on, the sheet will display all of the levels and settings for all master files attached to the nesting file.

In order for level display to work properly, MicroStation must have the variable MS_NEWLEVELDISPLAY set to 1.

See Section 3.5.1 for Nesting File Naming Convention.

2.5 WORKING FILES

Working files may be used by designers to develop various options for alignment, structures, or other facilities and may become either a master file or sheet file. Working files can contain information to be used for design, calculation support, or "DRAFT" purposes only. Working files are not for inclusion in a specific deliverable plan set, nor are they to be referenced from any plan sheet file.

See Section 3.3 for Working File Naming Convention.



2.6 FILE MANAGEMENT AND DIRECTORY STRUCTURE

CHSTP has established a file directory system used to maintain and organize all project related electronic CADD files. Standardized project directory structure promotes efficient and effective storage and retrieval of active and archived CADD files.

The CADD folder structure and general contents shall be as follows:

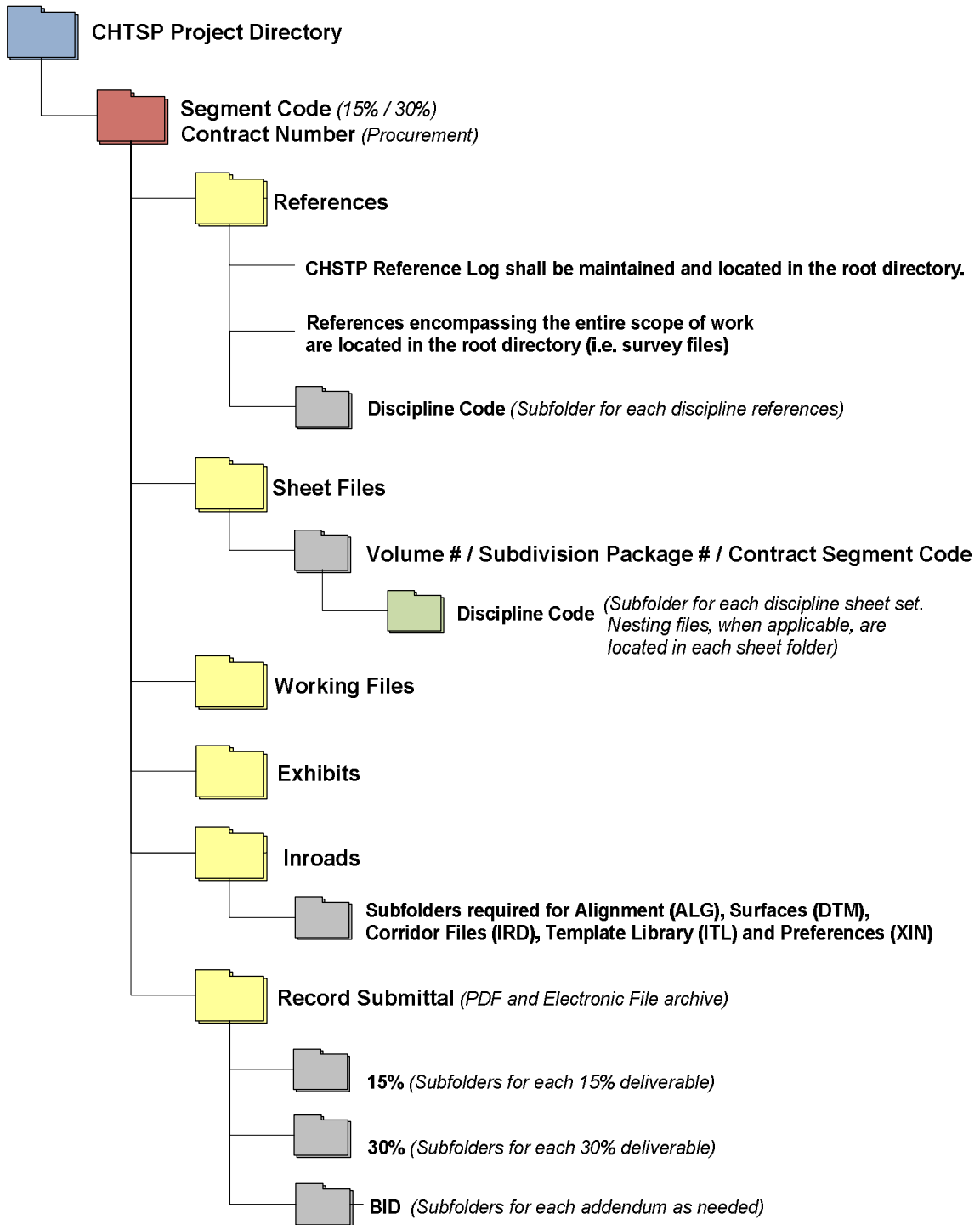

2.7 PROJECT COORDINATE SYSTEM

The California Coordinate System (CCS), North American Datum of 1983 (NAD83), shall be used for the horizontal coordinate system for the project. All CADD files shall adhere to the designated coordinate system to ensure that all design information can be readily transferred and integrated among various disciplines using reference files.

Source: Caltrans Surveys Manual - Chapter 4, Survey Datums:

http://www.dot.ca.gov/hq/row/landsurveys/SurveysManual/04_Surveys.pdf

2.8 PROJECT VERTICAL DATUM

The vertical datum for the CHSTP design shall be the North American Vertical Datum of 1988 (NAVD88), as defined by the National Geodetic Survey (NGS). For exceptions to this policy, see Caltrans Surveys Manual - Chapter 4, Survey Datums.

Source: Caltrans Surveys Manual - Chapter 4, Survey Datums:

http://www.dot.ca.gov/hq/row/landsurveys/SurveysManual/04_Surveys.pdf

2.9 PROJECT WORKING UNITS

CHSTP has established a Units.def file to ensure all project files have the same units defined. The master units, sub units, resolution and working area, as defined by the units.def and CHSTP seed files, for all CADD Drawings shall be the following:

Master Units (MU)----- Survey Feet (FT)

Sub Units (SU)----- Tenths (TN)

Resolution: ----- 10,000 per Foot

Working Area (each axis): ----- 170,591,236 Miles

The use of the CHSTP units.def is required and must be located in the file path defined in the MS_CUSTOMUNITSDEF variable.

Link to the units.def:

https://ww3.projectsolve2.com/eRoom/SFOF7/Engineering/0_8053e

2.10 PROJECT SEED FILES

A seed file is a CADD template file that standardizes all new drawings that are created. Every file started with the correct seed file will have the same global origin, working units, attached dgnlib, color table, text style and dim styles. Seed files shall not contain any design elements. When creating a new design file, the appropriate seed file shall be selected and copied to the desired folder and renamed based on the file naming conventions established in Section 3.0. Project seed files provide a method and means for standardizing all DGN files created for this project.

The CHSTP has six seed files each representing the CCS NAD83 zones designated by Caltrans as standards for a 2-D or 3-D environment and one seed file for architectural and structural design. The six zone seed files cover the proposed CHSTP alignment and shall be used for all sheets that need to remain geo-referenced. For design files that fall within two zones, designers shall use the seed file which encompasses the majority of design. Caltrans state zone designations are included in Appendix H.



All CHSTP CADD files must be created from the correct seed file. All files shall be 2D except for those in support of design vertical applications. The list of CHSTP seed files are as follows:

CHTSP Project Seed Files		
2D (geo-referenced)	3D (geo-referenced)	2d (Non geo-referenced)
2deseedZone1.dgn – Zone 1	3deseedZone1.dgn – Zone 1	Arch_Struc_seed.dgn
2deseedZone2.dgn – Zone 2	3deseedZone2.dgn – Zone 2	v8seed.dgn
2deseedZone3.dgn – Zone 3	3deseedZone3.dgn – Zone 3	v8seedz.dgn
2deseedZone4.dgn – Zone 4	3deseedZone4.dgn – Zone 4	
2deseedZone5.dgn – Zone 5	3deseedZone5.dgn – Zone 5	
2deseedZone6.dgn – Zone 6	3deseedZone6.dgn – Zone 6	

All CHSTP CADD files shall be created from the correct seed file.

Each seed file has been supplemented to include its associated geographic coordinate system setting based upon the CCS NAD83 zones. The coordinate system setting can be accessed via the workflow shown below:

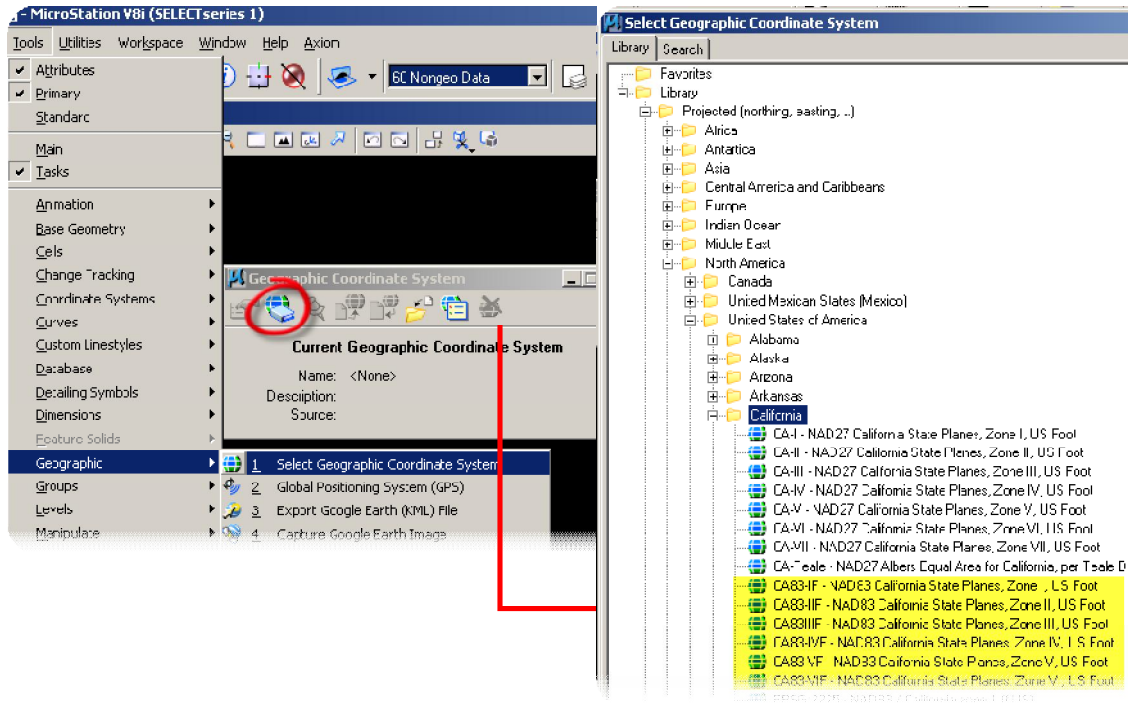

Link to the CHSTP seed files:

https://WW3.projectsolve2.com/eRoom/SFOF7/Engineering/0_8053e



2.11 PROJECT RESOURCE FILES

The following resources files are provided for the CHSTP project:

CHTSP RESOURCE FILES	
CHSTP.cel	Cell library established for the project
CHSTP.tbl	Color table established for the project
CHSTPvars.txt	Project variables to supplement MicroStation workspaces setups
Ctfont1.rsc*	Font resource file established for the project
CtIstyle.rsc*	Supplemental Line styles
CTCELLIB.cel*	Supplemental Civil Cell library
RWEnglish_v8.cel*	Supplemental Right of Way Cell Library
Stcel.cel*	Supplemental Structural Cell library

*Source: Caltrans Office of CADD and Engineering GIS Support

http://www.dot.ca.gov/hq/oppd/cadd/rsc_files/webpage.php:



3.0 CADD FILE NAMING CONVENTION

Design efforts shall result in the creation of numerous CADD files, including reference files, sheet files and working files. For the CHSTP, these standards will evolve to accommodate software, hardware and project advancement at logical conversion. The different file types, general usage and file naming convention are discussed below.

3.1 MASTER FILES

Master files contain discipline-specific design information in one continuous file and are referenced into sheet files (See Section 3.4 for description of sheet files). Additional or modified design information within a master file will automatically update in the sheet files.

Master files are tied to the project coordinate system and shall not be moved, rotated, or scaled in order to preserve the coordinate system within the file and allow other Master files to be attached coincident to each other. All master files are attached using **Coincident-World** method.

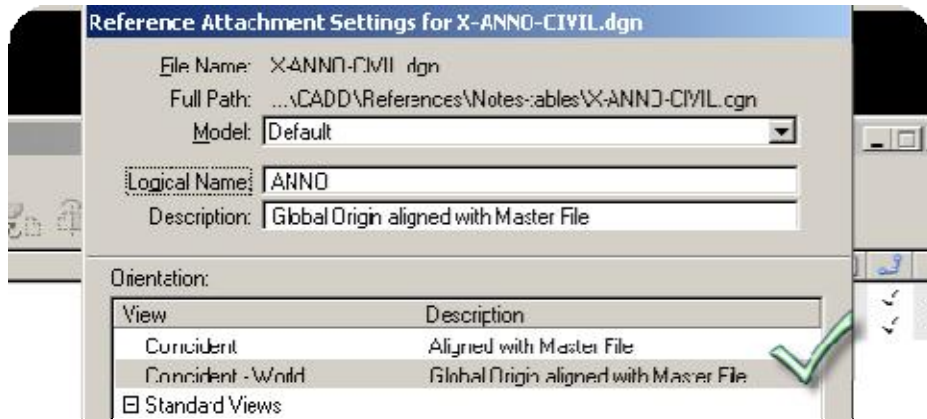

Master files shall not be nested. Nesting files are only permissible for sheet production. See Section 3.5.1 for nesting file information

3.1.1 Master File Naming Convention

Master files shall be named using a maximum of 20 characters (excluding hyphens and the three-digit DGN file extension) based on the following template:

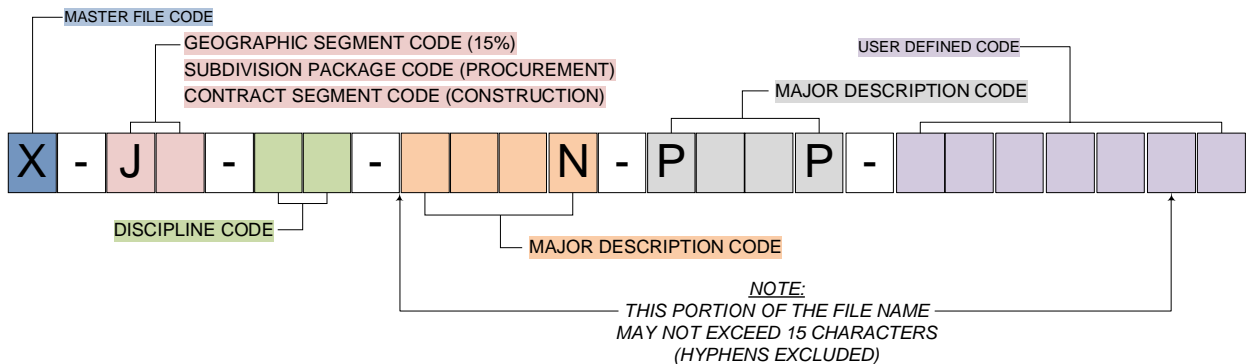

Example:

X-JM-TT-ALGN-PROP

San Jose to Merced, Proposed Track Alignment master file

3.1.2 Master File Code (One character)

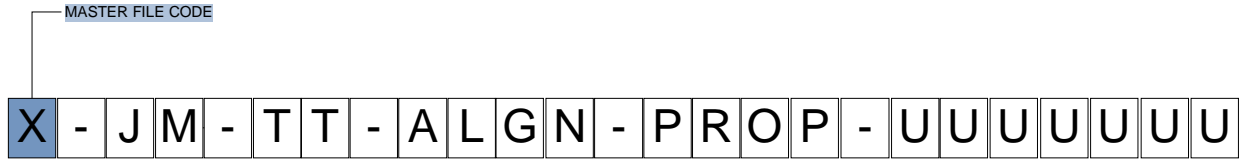

The first letter of all references shall describe its intended use. The two main master file codes are shown below:

“X”	Master Files prepared for and referenced into design deliverables drawings
“W”	Master Files prepared for preliminary purposes only and not inclusive of any design deliverable drawings.

See Section 3.3 for further information regarding working file descriptions and naming conventions.

3.1.3 Geographic Location Segment Code (Two characters) / Subdivision Package Code (Two characters)

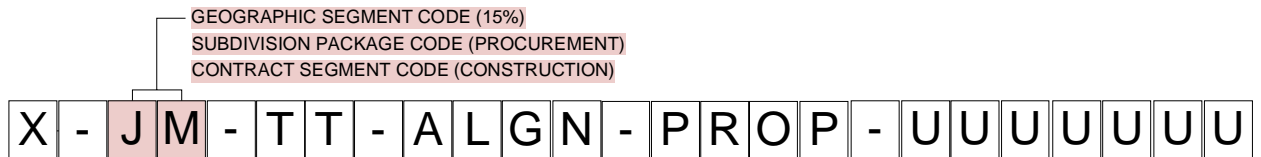

The SECOND and THIRD characters shall vary depending upon submittal type. During 15% and the SECOND and THIRD characters indicate the Geographic Location Segment Code, shorthand for one of the ten regional segment identifiers. For Preliminary Design for Procurement design, the SECOND and THIRD characters indicate the Subdivision Package Code, shorthand for procurement package types prepared for each of the CHSTP subdivisions. For construction drawings, the SECOND and THIRD characters indicate the Contract Segment Code, shorthand for the CHSTP subdivision design-build construction contract number plus the segment code for drawing packages prepared for each package.



The Segment Codes, utilized during 15% design, are as follows:

GEOGRAPHIC SEGMENT CODE	
Segment Identifier	Segment Code
San Francisco to San Jose	FJ
San Jose to Merced	JM
Altamont Pass	AJ
Sacramento to Merced	SM
Merced to Fresno	MF
Fresno to Bakersfield	FB
Bakersfield to Palmdale	BP
Palmdale to Los Angeles	PL
Los Angeles to Anaheim	LO
Los Angeles to San Diego	LD

The Subdivision Package Codes, utilized during Preliminary Design for Procurement, are as follows:

SUBDIVISION PACKAGE CODE*		
Package #	Subdivision	Description
1	S	Sierra Subdivision Construction Package 1 Procurement Documents

The Contract Segment Code, utilized during construction, is as follows:

CONTRACT SEGMENT CODE		
Contract Number**	Segment**	Description
####	UUU	Sierra Subdivision Construction Package 1 Construction Documents

*Subdivision Package Codes shall be established as procurement packages are prepared.

**Contract Number shall be established by the Authority. Segment Code shall be established by the contractor during the preparation of the construction drawings and submitted to the Authority for approval.



3.1.4 Discipline Code (Two characters)

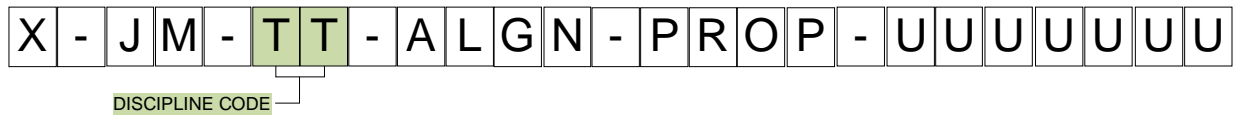

The FOURTH and FIFTH characters indicate the Discipline Code.

See Appendix C for a complete list of Discipline Codes.

3.1.5 Major Description Codes (Four characters)

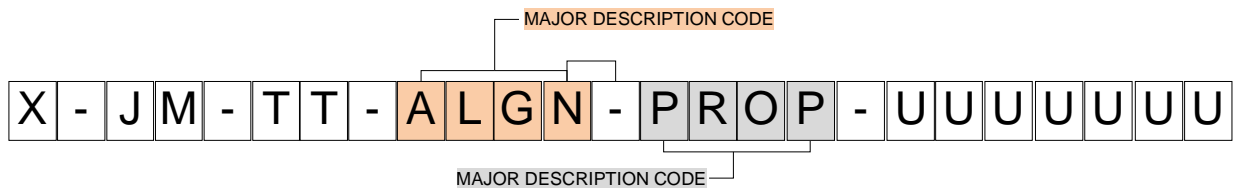

The SIXTH and THIRTEENTH characters indicate the Major Description Code. This four-character field code attempts to logically group together similar descriptions that cover multiple disciplines. Major codes can be combined to further differentiate and describe the master file. As shown in the example above, the major description code ALGN (alignment) is united with PROP (proposed) to create the reference file for proposed alignment line work.

The use of both major description codes is not required. A file name can contain one or two major discipline codes. The CHSTP has established a list of common major description codes that will be updated throughout the lifecycle of the project. For the list of Major Description Codes, see Appendix D.

For consistency throughout the master files, the use of the description code EXST (Existing) and PROP (proposed) shall always succeed another major description code. This will ensure that similar master files are group together. See example below:

Example:

X-JM-VS-EASE-EXST.dgn

X-JM-VS-EASE-PROP.dgn

San Jose to Merced, Existing and Proposed Survey Easement Files

3.1.6 User Defined Description Codes (Four characters)

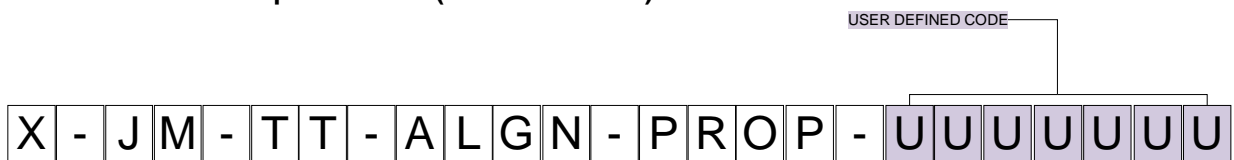

The FOURTEENTH and TWENTIETH characters indicate the user defined description code. The Major description codes are not intended to be all inclusive. There are instances when project specific descriptions will need to be created. In the case of user-defined description codes, they shall contain no more than 6 characters (alpha, numeric or a combination of both). The additional characters shall always be appended to the end of the file name.



As shown in the example below, a common user-defined description code is the plotting scale.

Example:

X-JM-TT-ALGN-200.dgn

San Jose to Merced, Proposed Track Alignment Master file, 200 scale

3.2 LOGICAL NAMES

Logical Names helps identify a reference attachment. It will also provide consistency throughout the entire project plan sets and make it easier to execute routines and scripts for process automation. The CHSTP project will have the following logical names for the major reference files found in most sheet types: (note when two instances of a reference is found in a sheet, a numerical suffix is added to the logical name, i.e. TOPO, TOPO1 and TOPO2).

CHSTP LOGICAL NAMES	
Reference	Logical Name
Border Reference	BDR
Track Horizontal Alignment Reference	TALGN
Track Alignment Vertical Profile Reference	TPROF
Road Horizontal Alignment Reference	RALGN
Road Alignment Vertical Profile Reference	RPROF
Topographic Reference	TOPO
Existing Utility Base map	XUTIL
Proposed Utility Base map	PUTIL
Structural Reference	STR
Annotation Reference	ANNO
Nesting Sheet Reference	NEST
Traction Power Reference	PWER
Grading Reference	GRAD
OCS Reference	OCS
Automatic Train Control Reference	ATC
Communication conduit Reference	COMM

3.3 WORKING FILES

Working files are used by designers to prepare various options and/or concepts of a design to avoid confusion and interference with reference files currently in use for actual deliverables. Using working files maintains a record of alternative conceptual design options that may have validity for the future but are not deemed “deliverables”. Working files contain project design information prepared only in support of the creation of design discipline drawings or calculations. Working drawings to be plotted for any purpose, including temporary use, inclusion in calculation sets, etc. will be clearly labeled “Working Drawing – DRAFT -” within the electronic file such that a clear distinction can be made from reference or sheet file plots.

Working files are not for inclusion in a specific deliverable plan set, nor are they to be referenced from any plan sheet file. However, CHSTP CADD standards do apply to CADD working files.



For consistency and differentiation from master files referenced into plan sheets, the nested filename shall begin with “W-”.

Example:

W-MF-TT-ALGN-PROP-UPRR

Merced to Fresno, Working file for Proposed Track Alignment, UPRR alternative

3.4 SHEET FILES

Sheet files shall contain north arrow, bar scale, notes, dimensions, etc and shall have attached appropriate reference files such as a standard project border file. Plotting for all drawings shall be done from the sheet files.

3.4.1 Sheet File Naming Convention

Sheet files shall be named using 12 characters (hyphens do not count as a character) plus the three character extension “DGN” based on the following template:

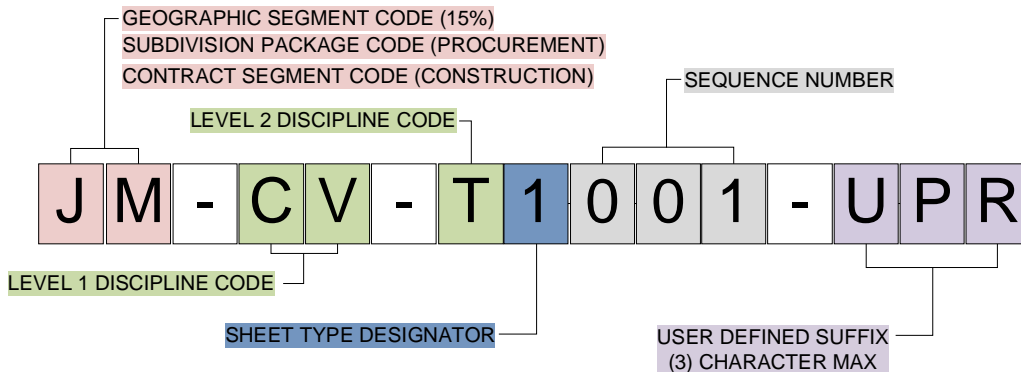

Information regarding the first two characters in the sheet file naming convention can be found in Section 3.1.3 of this manual

Example:

JM-CV-T1001-UPR.dgn

San Jose to Merced, Package 1, Civil Grade Separation, Plan and Profile Sheet Drawing Sequence Plan No. 001 for Alignment Alternative UPRR

3.4.2 Level 1 & 2 Discipline Code

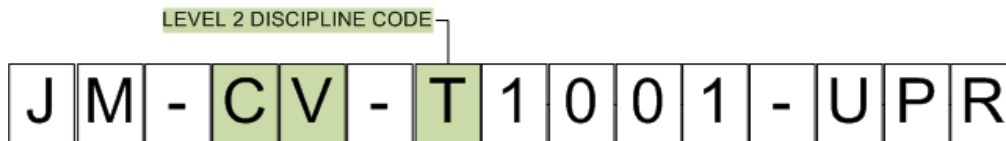

The THIRD, FOURTH and FIFTH character represent the Level 1 and Level 2 discipline codes. They are used to distinguish sheet sets within each of the various discipline procured for this project. For a complete list of Level 1 and Level 2 discipline codes Appendix C of the CADD Manual



3.4.3 Sheet Type Designators

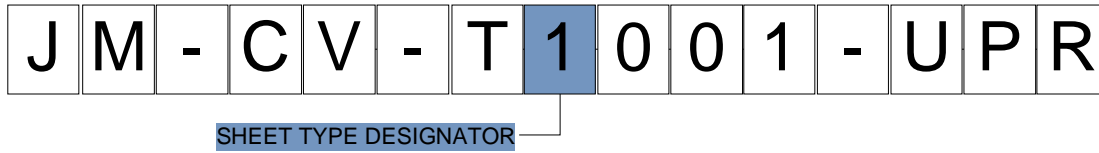

The SIXTH character indicates the Sheet Type Designator as established by the CHSTP Team. The sheet type is identified by a single numerical character. Sheet types apply across multiple disciplines. For a complete list of Sheet Type Designators, See Appendix E of the CADD Manual

3.4.4 Sequence Number

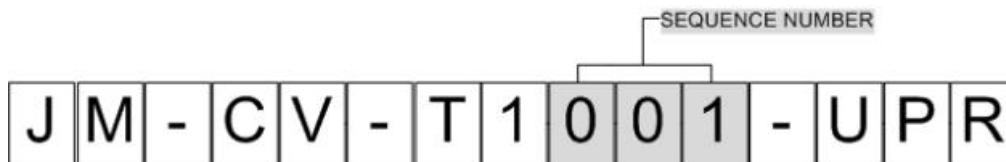

The SEVENTH through NINTH characters indicate the Sequence Number as established by the CHSTP Team. The sequence number will be assigned in series format, with each block of 100 drawings reserved for each discipline subset. First plan set of each set will start at 001. Subsequent sheets will follow as 002 thru 999.

3.4.5 User Defined Designator

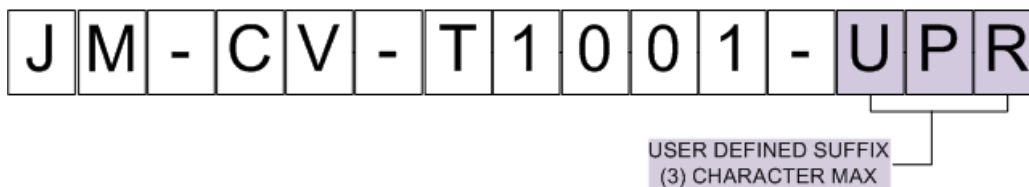

The TENTH through TWELFTH characters indicate a user defined designator as established by the CHSTP Team. The user defined is reserved as a necessary suffix to distinguish sheet files that can possibly have the same sheet number (i.e. in the case of an alignment alternative). The user defined code shall be a minimum of 1 character with a maximum of 3 characters.

3.4.6 Drawing Number

The drawings number to be shown in the title block shall be the sheet filename without the Contract Number or Geographic Segment Code and Package prefix.

Example:

CADD Filename: JM-CV-T1001-UPR.dgn

Drawing Number: CV-T1001-UPR



3.5 PLAN SHEET FILES

Information on plan sheet files usually requires the use of design reference files. Necessary design reference files shall be referenced to sheet files and clipped at the match lines to produce a design discipline drawing. The reference files, with the exception of the standard project border, *shall not be scaled, rotated or moved*, since this shifts the data away from the project coordinate system. The standard project border reference file shall be referenced, scaled, rotated and moved to cover the design information required on the design reference files. Also, the view shall be rotated so the border is horizontal.

Generally, civil and track plans as well as plans illustrating tunnel alignment will be produced in engineering scales (1"=10', 1"=20', et al). Station and Structural plans shall be shown in engineering and architectural scales (1/8"=1', 1/16", et al).

3.5.1 Nesting Files

Nesting files are reference files that are attached to the sheet files using the "live nesting" feature. A nesting file is a compilation of reference files that are displayed with the settings and level structure that are to be displayed in the sheet file. When the nesting file is attached to the sheet file with "live nesting" turned on, the sheet will display all of the levels and settings for all reference files attached to the nesting file.

To ensure consistency between a series of sheet files, all reference file and level manipulation in a series of sheets should be done directly to the nesting files and not from within the sheet itself.

For example, if 20 sheet files all showing spot elevations from the topography base map, you would go into the nesting file that referenced the topography base map, and was attached to all 20 sheets with "live nesting" turned on, and turn the level that contained spot elevations off directly in the nesting file. This in turn would cause that level to turn off in all 20 sheets. Also, if you wanted to add a particular reference file to all 20 sheets you would simply attach that file to the nesting file that was already attached (and clipped) to all of the sheet files, and in turn that file would be attached and displayed in all 20 sheets.

In order to ensure that nesting files are not inadvertently manipulated to alter the appearance of a particular drawing, each series of sheet files will have its own particular nesting files that are referenced to no other sheets or drawings, and in turn each nesting file will be referenced to only one series of drawings.

For consistency, the nested filename shall begin with "NEST-".

Example:

NEST-JM-TT-D1000.dgn

San Jose to Merced, Track Plan and Profile Sheet Nesting File

3.5.2 Borders

The CHSTP has two main borders for the use in design drawings and exhibits and figures respectively. Preliminary and design-build drawing shall use the X-BDR-CHSTP.dgn

Exhibits and sketches shall use EXH-BDR-CHSTP.dgn. See Appendix B for information regarding the borders.



3.5.3 Plan Sheet Drawing Scales

Drawings will be prepared at the following (full size drawing) scales:

- 15% Design Level (Civil)
 - Horizontal 1"=200'; Vertical 1"=20' For undeveloped areas
 - Horizontal 1"=200'; Vertical 1"=20' For developed areas
 - Horizontal 1"=100'; Vertical 1"=10' In constrained urban areas
 - Horizontal 1"=50'; Vertical 1"=5' at stations and special study areas and as appropriate to achieve design level
- Preliminary Design for Procurement Design Level (Civil)
 - Horizontal 1"=100'; Vertical 1"=10' for undeveloped, developed and constrained urban areas
 - Horizontal 1"=50'; Vertical 1"=5' at stations and special study areas and as appropriate to achieve design level
 - Structural & Architectural Scales per Caltrans Structural Seed file
- 15%/Preliminary Design for Procurement Design Level (Structures)
 - General Plan 1"=20' (for structures 150' or less)
 - Elevation 1"=20'
 - For structures 150' or greater, an appropriate engineering drawing scale is required. Plan and Elevation scales shall be identical.
- 15%/Preliminary Design for Procurement Design Level (Architecture)
 - Site Plan 1"=100'
 - Platform Plan 1"=50'
 - Enlarged Partial Platform Plan 1/16"=1' or 1"=20'
 - Concourse/Mezzanine Plan 1"=50'
 - Enlarged Partial Concourse Plan 1/16"=1'
 - Bldg Elevations 1/16"=1' or 1"=20'
 - Bldg Cross/Long Sections 1/16"=1' or 1"=20'

3.5.4 Elevation, Section and Detail Sheet Files

Information on elevation, section and detail sheet files does not require the use of design reference files, except for the standard project border and when necessary, the file itself. Sheet files also consist of schematics, line diagrams, charts and tables.

The Border file is always attached at scale 1"=1' (1:1) with the exception of General Elevation sheets. Other exceptions will be at CADD manager's discretion.



3.5.5 Mixing Drawing Scales

There are two drawing types where a mix of scale occurs: detail drawings (where it is known in advance that there will be details drawn at different scales), and plan drawings with details at a different scale than the rest of the sheet file. The instructions for both types of drawings are below.

Example Using Border Scale:

Detail Drawings: An Appropriate scale is chosen based upon the scale of the details. If the scales of details all vary, the border shall be attached 1"=1' (1:1). The use of a master detail file is permitted for the use of true scaling and measurement.

Plan Drawings: The border remains at its proper scale: 1"=30' (30:1), 1"=100' (100:1), etc. Details are scaled appropriately as needed.



4.0 LEVELS AND SYMBOLOGY

4.1 GENERAL

Design information within a CADD file is organized into levels. For each discipline, each design element shall be drawn on its appropriate level and symbology. It is important that the level structure is followed. Symbology (color, line style, line weight) for all levels should be set to “By Level”. This will ensure that the correct symbology is automatically selected when a level is chosen. Proper use of levels affords all CADD users the flexibility to turn on or off design data necessary for different drawings.

4.2 DESIGN FILE LIBRARIES (DGNLIB)

Design File Libraries (DGNLIBs) are files that set the level names, level symbology, text and dimension styles and are referenced to the project workspace at the start of a MicroStation session. The CADD user should never have to attach the project dgnlib file nor have to manually change any settings for placing text or dimensions. If a special situation calls for additional levels or to modify text or dimension styles, the requests shall be made via the CHSTP CADD Standards request sheet. See Appendix F for additional information regarding the DGNLIB.

Link to CHSTP CADD Standards request sheet:

https://WWW3.projectsolve2.com/eRoom/SFOF7/Engineering/0_c3557

4.3 FONTS AND TEXT

It is important to place text at the appropriate size within the drawing based upon the intended scale of the plotted plan sheet for clarity and readability of text. For consistency, the fonts and text sizes are defined within dgnlib file by scale. The below chart defines the text and fonts sizes to be used in all packages and discipline.

Engineering			
Scale	Text Height and Width		
	Text (Font 3)	Subtitle (Font 3)	Title (Font 43)
1"=1'	0.14	0.175	0.2
1"=5'	0.70	0.875	1
1"=10'	1.40	1.75	2
1"=20'	2.80	3.5	4
1"=30'	4.20	5.25	6
1"=40'	5.60	7	7
1"=50'	7.00	8.75	10
1"=60'	8.40	10.5	12
1"=80'	11.20	14	16
1"=100'	14.00	17.5	17.5
1"=200'	28.00	35	40
1"=500'	70.00	87.5	100



ARCHITECTURAL			
Scale	Text Height and Width		
	Text (Font 3)	Subtitle (Font 3)	Title (Font 43)
3"=1'	0.046	0.058	0.066
1 1/2"=1'	0.094	0.117	0.134
1"=1'	0.140	0.175	0.200
3/4"=1'	0.186	0.233	0.266
1/2"=1'	0.280	0.350	0.400
3/8"=1'	0.373	0.467	0.533
1/4"=1'	0.560	0.700	0.800
3/16"=1'	0.746	0.933	1.066
1/8"=1'	1.120	1.400	1.600
3/32"=1'	1.494	1.867	2.134
1/16"=1'	2.240	2.800	3.200

4.3.1 Text Placement Guidelines

The following guidelines should be followed when placing text:

- All lettering shall be upper case.
- Custom fonts should not be used.
- Underlining shall not be placed as a separate element. Blank spaces on either side of the text may not be inserted to make the underlining longer than the text.
- Stacked fractions ($\frac{1}{2}$) are required.

4.4 DIMENSIONING

Automatic Dimensioning shall be used for all drawings. Similar to text settings, dimension Settings are set within the **CHSTP.dgnlib** design file library.

Dimension text shall be placed on the appropriate text level with "By Level" symbology.



The dimension alignment modes shall be either view or true. View will allow Automatic Dimensioning to be placed aligned with the drawing view. True will allow automatic dimensioning to be placed true to the element, usually when the element is on an angle from the view. Dimensions shall be placed as necessary and the text shall always be aligned with the dimension line as shown below.

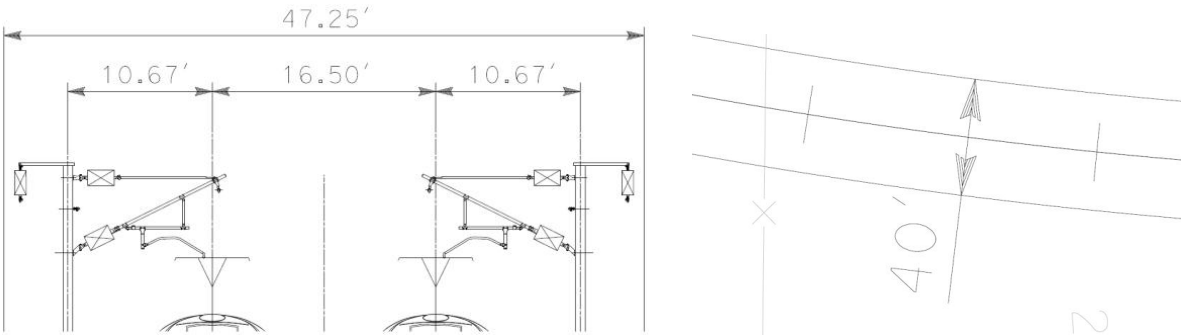

4.5 LINE STYLES

The project line style resource file is **CHTSP.rsc**. The CHSTP line style resource file has been generated from the Caltrans line style resource file (ctlstyle.rsc). MicroStation's default line styles 0 thru 7 are also accessible. The line styles are assigned to levels using By Level in Level Manager. See Appendix G for a complete list of line styles.

5.0 PLOTTING AND PEN TABLES

5.1 PLOTTING

All hard copies will contain plot stamps. This plot stamps can be found on the left margin of the border file. This stamp identifies the name and path of the DGN file, the time and date plotted, the name of the operator who plotted the copy, and the design script used for the plot.

5.2 PLOT DRIVERS

Plot drivers shall be used for all design drawing printing. The plot drivers have been established based upon plot size and plot color output. Plot drivers shall not be modified. Any request for changes must be done via the CHSTP CAD Standard Request Form found in Appendix A. The plot drivers to be used on the project are:

PLOTTING FILES	
CHSR_full_black.plt	Black/White Full Size (22x34) System Printer Plot Driver
CHSR_full_color.plt	Color Full Size (22x34) System Printer Plot Driver
CHSR_half_black.plt	Black/White Half Size (11x17) System Printer Plot Driver
CHSR_half_color.plt	Color Half Size (11x17) System Printer Plot Driver
CHSR_PDF_full_black.plt	Black/White Full Size (22x34) PDF Plot Driver
CHSR_PDF_half_black.plt	Black/White Half Size (11x17) PDF Plot Driver

5.3 PEN TABLE

The Pentable provides the text substitutions for the plot stamps found in the border file. It does not control any printing attributes for drawing entities with the exception of the topographic survey file. The screening colors, screening levels and text substitutions found in the pen table show below:

SCREENING COLORS		SCREENING LEVELS	
CO = 130	: Preliminary Design for Procurement Black	LV = 2-12	: 40% Black
CO = 140	: 40% Black		
CO = 150	: 50% Black		
CO = 160	: 60% Black		
FILL = 250	: 100% Screen (masking fill)		

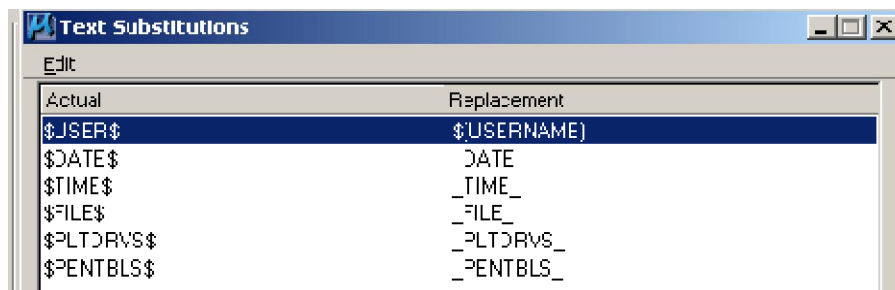

APPENDIX A – CHSTP CADD STANDARDS REQUEST FORM



California High-Speed Rail CADD Standards Request Form

Name: _____

Segment: _____

Date Submitted: _____

CADD Standards Category

Levels/DGNLib

File Naming Convention

CellLib

Abbreviations

LineStyles

Seed Files

Misc

Summary of Request:

Reviewed By: _____

Response:



APPENDIX B – BORDERS







APPENDIX C – LEVEL 1 & LEVEL 2 DISCIPLINE DESIGNATOR

Note: Each Design Drawing must have a Level 2 Designator Code. Addendums to the Level 2 Designator Code list shall be incorporated at the CADD Manager's discretion via the CHSTP CADD Standards Request Form. Link shown below:

https://WW3.projectsolve2.com/eRoom/SFOF7/Engineering/0_c3557

Discipline Designator		ARCHITECTURE
Level 1	Level 2	Level 2 Description
AR	B	General
AR	C	Site Plan
AR	D	Platform Plan
AR	F	Concourse/Mezzanine Plan
AR	H	Roof Plans
AR	J	Station
AR	Y	User defined
Discipline Designator		CIVIL
Level 1	Level 2	Level 2 Description
CV	B	General
CV	D	Demolition
CV	G	Grading and Drainage
CV	H	Hydrology
CV	I	Construction Staging
CV	P	Paving
CV	R	Roadways
CV	S	Site
CV	T	Grade Separation/Crossings
CV	Y	User Defined



Discipline Designator		COMMUNICATIONS
Level 1	Level 2	Level 2 Description
CO	B	General
CO	C	System Architecture
CO	D	Logical
CO	E	Functional Site Layout
CO	F	Physical Site Layout
CO	G	Typical Device and Installation Details
CO	Y	User Defined
Discipline Designator		ELECTRIC
Level 1	Level 2	Level 2 Description
EL	B	General
EL	L	Lighting
EL	Y	Auxiliary Systems
EL	S	Instrumentation
EL	Y	User Defined
Discipline Designator		FIRE PROTECTION
Level 1	Level 2	Level 2 Description
EL	B	General
EL	L	Detection and Alarm
EL	S	Fire Suppression
EL	Y	User Defined
Discipline Designator		GENERAL
Level 1	Level 2	Level 2 Description
GE	A	Index of Drawings
GE	B	General Notes
GE	C	Abbreviations and Symbols
GE	D	Key Map



Discipline Designator		GEOTECHNICAL
Level 1	Level 2	Level 2 Description
GT	B	General
GT	Y	User Defined
Discipline Designator		LANDSCAPING
Level 1	Level 2	Level 2 Description
LA	B	General
LA	D	Demolition
LA	J	Irrigation
LA	L	Lighting
LA	P	Planting
LA	R	Relocation
LA	Y	User Defined
Discipline Designator		MAINTENANCE
Level 1	Level 2	Level 2 Description
MY	B	General
MY	C	Overall Site Plan
MY	D	Yard Track Plans
MY	E	Yard Systems Plans (TC and OCS)
MY	Y	User Defined
Discipline Designator		MECHANICAL
Level 1	Level 2	Level 2 Description
ME	B	General
ME	D	Demolition
ME	H	HVAC
ME	J	Instrumentation
ME	P	Piping
ME	S	Site
ME	Y	User Defined



Discipline Designator		OVERHEAD CONTACT SYSTEM
Level 1	Level 2	Level 2 Description
OC	B	General
OC	C	OCS Schematic
OC	D	OCS Layout
OC	E	OCS General Arrangement
OC	F	OCS Assembly
OC	G	OCS Technical/Wire
OC	H	OCS Foundations
OC	J	OCS Grounding and Bonding
OC	Y	User Defined
Discipline Designator		PLUMBING
Level 1	Level 2	Level 2 Description
PL	B	Site
PL	C	Equipment
PL	D	Piping
PL	Y	User Defined
Discipline Designator		RIGHT-OF-WAY
Level 1	Level 2	Level 2 Description
RW	B	General
RW	C	Key Map and Line Index
RW	M	Appraisal Map
RW	Y	User Defined
Discipline Designator		STRUCTURES
Level 1	Level 2	Level 2 Description
ST	B	General
ST	C	Demolition
ST	D	Framing
ST	E	Building
ST	F	Column/Footings
ST	G	Retaining Wall
ST	H	Substructure
ST	J	Viaducts
ST	K	Bridges
ST	Y	User Defined



Discipline Designator		SURVEY / MAPPING
Level 1	Level 2	Level 2 Description
VS	B	General
VS	C	Survey Data Control Sheets
VS	D	Existing Condition/Topography Plans
VS	Y	User Defined
Discipline Designator		TRACK
Level 1	Level 2	Level 2 Description
TT	B	General
TT	C	Key Map
TT	D	Alignment Drawings
TT	E	Track Chart
TT	Y	User Defined
Discipline Designator		TRACTION POWER
Level 1	Level 2	Level 2 Description
TP	B	General
TP	C	One-Line Diagrams
TP	D	Traction Power Facility Layouts
TP	E	Equipment Arrangements - Prefabricated Enclosures
TP	F	TPS Interface Drawings
TP	G	Neutral Return Systems
TP	H	Relay and Metering
TP	J	Ground Grid
TP	L	SCADA Points List
TP	M	Cable and Conduit Schedules
TP	N	Duct Banks and Manholes
TP	O	TPS Site Plans
TP	P	TPS Utility Relocation Plans
TP	Q	TPS Site Grading and Paving Plans
TP	R	TPS Foundation Plans and Details
TP	Y	User Defined



Discipline Designator		TRAIN CONTROL
Level 1	Level 2	Level 2 Description
TC	B	General
TC	C	Single Line Diagrams
TC	D	Double Line Diagrams
TC	E	Schematics
TC	F	Interlocking Site Plans and Layouts
TC	G	Interlocking houses, foundations, and site details
TC	H	Wayside equipment cases, foundations, and site deta
TC	J	Signals, indicators, and fixed signs
TC	K	Switch layouts and equipment
TC	L	Track mounted equipment
TC	Y	User Defined
Discipline Designator		TUNNEL
Level 1	Level 2	Level 2 Description
TN	B	General
TN	C	Tunnel Configurations
TN	D	Portals and Shafts
TN	E	Niches/Auxiliary Structure
TN	F	Fixed Equipment
TN	Y	User Defined
Discipline Designator		UTILITY
Level 1	Level 2	Level 2 Description
UT	B	General
UT	C	Composite Utility Plan
UT	D	Utility Protection and Relocation
UT	Y	User Defined



APPENDIX D – MAJOR DESCRIPTION CODES

Major Description Codes	
025Y	25-year mark
050Y	50-year mark
100Y	100-year mark
200Y	200-year mark
ABLT	Anchor bolts
ABOV	Above
ABUT	Abutment
ACCS	Access
ADAL	ADA requirement line work
AERL	Aerial
ALGN	Alignment
ALRM	Alarm system
ANNO	Annotation
AREA	Area
ASPH	Asphalt
AUXL	Auxiliary systems
BACK	Back
BARR	Barrier
BASN	Stilling and settling basin
BBAC	Battery backup
BCST	Broadcast related system (radio or TV)
BEAM	Beams
BEDS	Perennial and annual beds
BELL	Bell system
BENT	Top of bent
BKRS	Breakers
BLBD	Boiler blow down piping
BLDG	Buildings and primary structures
BLIN	Baseline
BMRK	Benchmarks
BNDY	Boundaries
BORE	Borings
BOTM	Bottom
BRCG	Bracing
BRDG	Bridge
BRDR	Border
BRKL	Break lines



BRNG	Bearings and distance labels
BUOY	Buoy
CABL	Cable systems
CATH	Cathodic Protection System
CATV	Cable television system
CCTV	Closed-circuit television system
CD~~	Condensate drain-system
CIPR	Culvert inlet protection
CIRC	Circuits
CITY	City
CLAS	Classifications
CLNG	Ceiling
CLOK	Clock system
CMPR	Computer
CNDT	Diversionary/bypass conduit/culvert
CNMB	Circuit numbers
CNST	Construction Staging
CNTE	Construction entrance
CNTJ	Construction joint
CNTR	Center
CNTY	County
COAX	Coax cable
CODE	Code compliance plan
COLS	Columns
COMM	Communications
CONC	Concrete
CONT	Controls and instrumentation
COVR	Coverage
CRIT	Critical
CTLA	Controlled access
CTLJ	Control joint
CTNR	Container or planter
CTRL	Control points
CURB	Curb
CURV	Curve
DATA	Data
DECK	Deck
DEPR	Depression
DETL	Detail
DEVC	Devices
DIAG	Diagrams
DIMS	Dimensions



DOOR	Doors
DRIV	Driveways
DRNG	Drainage
DTCH	Ditches or washes
DUCT	Ductwork
EDGE	Edge
ELEC	Electrical
ELEV	Elevation
ELHT	Electric heat
EMER	Emergency
ENCL	Equipment enclosures
ENER	Energy management systems
EPIP	Equipment with piping and electricity
EQPM	Equipment
EROS	Erosion and sediment control
ERTH	Earth
ESMT	Easements
EVAC	Evacuation plan
EXHS	Exhaust system
EXIT	Exit
EXST	Existing
EXTR	Exterior
FACE	Face
FALT	Fault lines
FDPL	Flood plain
FDTA	Field data
FENC	Fences
FIBR	Fiber optics cable
FILL	Fill and cover material
FIRE	Fire protection
FIXD	Fixed
FIXT	Fixtures
FLDR	Floor drains
FLOR	Floor
FLOW	Flow line
FNDN	Foundation
FNSH	Finishes
FORC	Force main
FREE	Freestanding
FRMG	Framing
FTNG	Footings
FURN	Furnishings



GAGE	Gauge
GATE	Gate
GCVR	Ground cover
GENF	General features
GNDW	Ground water
GRAL	Guard rail
GRBM	Grade beams
GRID	Grid
GRLN	Grade line
GRND	Ground
GRTG	Grating
GRVL	Gravel
HIDD	Objects or lines hidden from view
HOLE	Holes
HORZ	Horizontal
HOSE	Hoses
HRAL	Handrails/guard rails
HVAC	HVAC systems
HWAL	Headwall
HWTR	Hot water heating system
HYDR	Hydraulic structure
INEG	Ingress/egress
INPR	Inlet protection
INST	Instrumentation
INTC	Intercom / PA systems
INTK	Intake
INTR	Interior
IRRG	Irrigation
JACK	Jacks
JAMB	Door and window jambs
JBOX	Junction box
JNTC	Control joint
JNTS	Joints
KYMP	Keymap
LABL	Labels
LAND	Land
LEAS	Lease
LEGN	Legend, symbols keys
LEVE	Levee
LICN	License
LITE	Lighting
LOCN	Limits of construction



LONG	Longitudinal
LOWR	Lower
LSCP	Landscape
LTNG	Lightning protection system
LTRL	Lateral pipe
MAIN	Mainline
MAJR	Major
MARK	Section Markers
MATC	Match lines
MNTG	Mounting system
MPIP	Miscellaneous piping systems
MSNW	Masonry
MULT	Multi-conductor cable
MVNG	Moving/Suspended
NGAS	Natural gas systems
NODE	Node
NOTE	Notes
NPLT	Non-plotting graphic information
NSBR	Noise barrier
OBJT	Objects
OPNG	Openings
OTLN	Outline
OVHD	Overhead
PADS	Pads
PANL	Panels
PATT	Texture or hatch patterns
PAVR	Unit pavers
PCAP	Pile caps
PCST	Pre-cast concrete
PERM	Permanent
PHON	Telephone system
PIER	Drilled piers
PILE	Piles
PIPE	Piping
PLAN	Plan
PLAT	Platform
PLNT	Plant and landscape material
PLYW	Plywood
PMIT	Permit
PNLS	System panels
PNPT	Point



POLE	Poles
POLM	Pole-mounted
POND	Ponds
POST	Posts
POWR	Power
PPIP	Process piping
PRCL	Parcels
PRIM	Primary
PRKG	Parking
PROC	Process systems
PROF	Profile
PROP	Proposed
PROT	Fire protection system
PRPT	Parapet
PRTN	Partitions
PRTY	Property
PVMG	Pavement markings
PVMT	Pavement
RAIL	Railroad
RAIS	Raised
RAMP	Ramp
RATE	Ratings
RBAR	Reinforcing bar
RCON	Reinforced concrete
RDGE	Roof ridges
RLOC	Relocation
RETN	Return
REVC	Revision clouds
REVS	Revision indicators and text
RFDR	Roof drains
RFEQ	Rooftop equipment
RISR	Risers
RIVR	River
ROAD	Roadway
ROCK	Large rocks and rock outcroppings
ROOF	Roof
RRAP	Riprap
RSRV	Reservation
RTWL	Retaining wall
RWAY	Right-of-way
SATD	Satellite dishes
SAUD	Audio signal



SBCK	Setback lines
SBST	Substations
SCHD	Schedules
SCOM	Communications signal
SCTL	Control signal
SDAT	Data signal
SDGA	Digital audio signal
SDGV	Digital video signal
SEAT	Seating
SECD	Secondary
SECT	Section
SEED	Seeding areas
SGHT	Sight distance
SHAD	Shadow area
SHEA	Structural bearing or shear walls
SHLF	Wall-mounted shelving
SIGN	Signage
SILL	Window sills
SILT	Silt fence
SITE	Site features
SIZE	Ductwork size
SKCH	Sketch
SKLT	Skylight
SLAB	Slab
SLVE	Pipe sleeve
SMIC	Microphone signal
SMOK	Smoke detector/heat sensors
SOIL	Soils
SOUN	Sound system
SPCL	Special systems
SPKL	Sprinklers
SPLY	Supply
SPOT	Spot elevations
SSWR	Sanitary sewer
STAN	Stationing
STAT	State
STEL	Steel
STEP	Steps
STOR	Storage
STRC	Structures
STRM	Storm sewer
STRP	Striping



STRS	Stairs
SUBD	Subdivision (interior) lines
SUBS	Sub-surface areas
SUPT	Support
SURF	Surface areas
SURV	Survey
SUSP	Suspended elements
SWAY	Spillway
SWBD	Switchboards
SWCH	Switches
SWLK	Sidewalks
SWMT	Storm water management
SWNF	Solvent waste non-flammable-system
SYMB	Reference symbols
TABL	Data tables
TANK	Storage tanks
TEMP	Temporary
TEST	Test stations
TEXT	Text
THER	Thermostats
TICK	Tick marks
TILE	Tile
TINN	Triangulated irregular network
TITL	Drawing or detail titles
TOPB	Top of bank
TOPO	Topographic feature
TOWR	Towers
TPIT	Test pits
TRAC	Tract lines
TRAK	Track
TRAL	Trails or paths
TRAN	Transmission system
TRAV	Transverse
TRAY	Cable tray and wire ways
TREE	Trees
TRUS	Trusses
TSHP	Town or township
TTLB	Titleblock stamp in borders
TURF	Lawn areas
TVVS	Television and video system
UGND	Underground
UPPR	Upper



UPVD	Unpaved surface
URAC	Under-floor raceways
UTIL	Utilities
VACU	Vacuum
VALV	Valves
VEGE	Trees, shrubs, and other vegetation
VENT	Vents
VERT	Vertical
VIEW	View
VOID	Void regions
WALL	Walls
WATR	Water supply
WDWK	Architectural woodwork
WELL	Well
WETL	Wetlands
WIRE	Wiring
WKSF	Work surface
WOOD	Wood
WWAY	Waterway
XFMR	Transformers
ZONE	Zoning



APPENDIX E – SHEET TYPE DESIGNATORS

Sheet Type Designators	
0	General Drawings (Title Sheet, Drawing Index, Data Tables, Notes, Typical Sections and Abbreviations/Symbols)
1	Plan and Profile, and Profile view only
2	Elevation
3	Sections (Section View, Wall Sections and Cross Sections)
4	Enlarged Plan View
5	Details
6	Schedules, Schematics, Charts, Tables and Diagrams
7	User Defined 1 (for sheet types that do not fall in the categories as defined above)
8	User Defined 2 (for sheet types that do not fall in the categories as defined above)
9	3D Renderings



APPENDIX F – DGNLIB

CHSTP DGNLIB Levels	
Level Prefix	Description
1-9,11-12	Caltrans Existing Survey Levels. For use in the topographic survey file only
RD	Caltrans Existing Level 0-999. Level number replaced with RD prefix. Items of work within this category include roadway, utility, structural and right of way
TT	Track alignment items including station line, annotation, track grid and existing railroad facilities
TP	Traction Power items including traction power site facilities, equipment, symbols and annotation.
OC	Overhead Contact System items including OCS poles, equipment and annotation
AC	Automatic Train Control items including signal houses, interlocking site, train control equipment and annotation.
CO	Communications items including conduits, communication site facilities and annotation
MY	Maintenance Facility items including maintenance yard track, maintenance site facilities and annotation



CHSTP DGNLIB Level		
Number	Name	Description
1	RD Control	(Includes Survey Monuments)
2	RD Exist Man Made	Exist Man-Made Features
3	RD Exist Rdwy	Exist Roadway Features
4	RD Exist Veg_Nat	Exist Veg & Natural Features
5	RD Exist Utils	Exist Utility Features
6	RD Exist Hydro	Exist Hydrographic Features
7	RD Contours	Relief Features / Contours
8	RD Spot Elev	Spot Elev / Contour Annotation
9	RD Profile Grid	Profile Grid
10	RD Sheet Format	(Includes North Arrow)
11	RD Undefined	Undefined level
12	RD Coord Grid	Coordinate Grid
13	RD Ramp Align	Ramp Over & Undercrossing Align
14	RD Ramp Anno	Ramp Over & Undercrossing Anno
15	RD Main Align	Mainline Alignment Data
16	RD Main Anno	Mainline Annotation Data
17	RD Front Align	Frontage Rd Alignment Data
18	RD Front Anno	Frontage Rd Alignment Annotation
19	RD Undefined	Undefined level
20	RD Pave Edges	Pavement Edges
21	RD Curb Gutter	Curbs Gutters & Dikes
22	RD Misc Cnst Det	Misc Construction Details
23	RD Layout Notes	Layout Notes
24	RD Oblit_ACRsurf	Obliteration & AC Resurfacing
25	RD Temp Rdwys	Temp Road Connection & Alignment
26	RD Undefined	Undefined level
27	RD Undefined	Undefined level
28	RD Undefined	Undefined level
29	RD Irrigation-Ex	Irrigation (Existing)
30	RD Cut and Fill	Cut & Fill
31	RD RW (exist)	ROW_Easement & Ownership Lines
32	RD RW Line_Fence	Right of Way Lines & Fences
33	RD RW Text	ROW Annotation
34	RD WPC Temp	Temp WPC & BMP
35	RD Erosion Cntrl	Permanent Erosion Control
36	RD Drainage	Drainage
37	RD Drain Anno	Drainage Annotation
38	RD San Sewer	Sanitary Sewer
39	RD SanSewer Anno	Sanitary Sewer Annotation



40	RD New Utility	(Includes Annotation)
41	RD ContourGrade	Contour Grading
42	RD Pave Elev	Pavement Elevations
43	RD Pave Marker	Pavement Markers & Striping
44	RD PaveMark Anno	Pavement Markers & Striping Anno
45	RD Signing	Signing
46	RD Const Signing	Construction Area Signing
47	RD Electrical	Electrical
48	RD Elect Anno	Electrical Annotation
49	RD Planting	Planting & Landscaping
50	RD IrrigationNew	Irrigation (New)
51	RD Stage 1	Stage 1 Const &Temp Traffic
52	RD Stage 1 Anno	Stage 1 Const &Temp Traffic Anno
53	RD Stage 2	Stage 2 Const &Temp Traffic
54	RD Stage 2 Anno	Stage 2 Const &Temp Traffic Anno
55	RD Stage 3	Stage 3 Const &Temp Traffic
56	RD Stage 3 Anno	Stage 3 Const &Temp Traffic Anno
57	RD Undefined	Undefined
58	RD Soundwalls	Soundwalls
59	RD Sndwall Anno	Soundwall Annotation
60	RD Nongeo Data	Nongeographical Drawing Data
61	RD HQ Changes	Headquarters Changes
62	RD AsBuilt Chng	As-Built Changes
63	RD Seal and Sig	Engr Seal & Signature
64	RD No_Plot	Data does not plot
65	RD No_Plot	Data does not plot
66	RD No_Plot	Data does not plot
67	RD No_Plot	Data does not plot
68	RD No_Plot	Data does not plot
69	RD No_Plot	Data does not plot
70	RD Plot_Shape	Plot shape for IPlot - DOES NOT PLOT
71	RD Survey Misc Breaklines	Survey misc breaklines
72	RD Survey Lines Point Data	Survey lines point data
73	RD Survey Point Data	Survey point data
74	RD Survey Boundary	Survey boundary
75	RD OTS Submittal	Stamp information
76	RD 15% In Progress Submittal	Stamp information
77	RD 15% Draft Submittal	Stamp information
78	RD 15% Final Submittal	Stamp information
79	RD PEFP Draft Submittal	Stamp information
80	RD PEFP Final Submittal	Stamp information
81	RD Undefined	Undefined level



82	RD Undefined	Undefined level
83	RD Undefined	Undefined level
84	RD Undefined	Undefined level
85	RD Undefined	Undefined level
86	RD Undefined	Undefined level
87	RD Undefined	Undefined level
88	RD Undefined	Undefined level
89	RD Undefined	Undefined level
90	RD Undefined	Undefined level
91	RD Undefined	Undefined level
92	RD Undefined	Undefined level
93	RD Undefined	Undefined level
94	RD Undefined	Undefined level
95	RD Undefined	Undefined level
96	RD Undefined	Undefined level
97	RD Undefined	Undefined level
98	RD Undefined	Undefined level
99	RD Undefined	Undefined level
100	RD Undefined	Undefined level
101	RD Undefined	Undefined level
102	RD Undefined	Undefined level
103	RD Undefined	Undefined level
104	RD Undefined	Undefined level
105	RD Undefined	Undefined level
106	RD Undefined	Undefined level
107	RD Undefined	Undefined level
108	RD Undefined	Undefined level
109	RD Appraisal Map	Appraisal Map Sheet Data
110	RD Sheet Format	(Includes North Arrow)
111	RD Record Map	Record Map Sheet Data
112	RD Undefined	Undefined level
113	RD Undefined	Undefined level
114	RD Undefined	Undefined level
115	RD Undefined	Undefined level
116	RD Undefined	Undefined level
117	RD Undefined	Undefined level
118	RD Undefined	Undefined level
119	RD Parcel Color	Parcel Color 19
120	RD Parcel Color	Parcel Color 20
121	RD Parcel Color	Parcel Color 21
122	RD Parcel Color	Parcel Color 22
123	RD Parcel Color	Parcel Color 23



124	RD Parcel Color	Parcel Color 24
125	RD Parcel Color	Parcel Color 25
126	RD Parcel Color	Parcel Color 26
127	RD Parcel Color	Parcel Color 27
128	RD Exist Ease L	Exist Easement Linework
129	RD Exist Ease A	Exist Easement Annotation
130	RD Exist RW A	Existing RW Annotation
131	RD Exist RW L	Existing RW Linework
132	RD New RW L	New RW Linework
133	RD New RW A	New RW Annotation
134	RD New Ease L	New Easement Linework
135	RD New Ease A	New Easement Annotation
136	RD Temp Ease L	Temporary Easement Linework
137	RD Temp Ease A	Temporary Easement Annotation
138	RD Minor Land L	Minor Landnet Linework
139	RD Minor Land A	Minor Landnet Annotation
140	RD Major Land L	Major Landnet Linework
141	RD Major Land A	Major Landnet Annotation
142	RD PBndy FedPart	Political Bndy Fed Participation
143	RD JUA_CCUA	JUA_CCUA Linework & Annotation
144	RD Relinquishmt	Relinquishment Linework & Anno
145	RD DirectorsDeed	Directors Deed Linework & Anno
146	RD Vac_Abandon	Vacation_Abandonment Lines_Anno
147	RD LandnetPts-NP	Non-plotted Landnet Point Data
148	RD RW Pts - NP	Non-plotted RW Point Data
149	RD Points-Plot	Plotted Landnet & RW Point Data
150	RD Retracement L	Surveyors Retracement Linework
151	RD Retracement A	Surveyors Retracement Annotation
152	RD Retracement C	Surveyors Retracement Comments
153	RD Clip Boundary	Reference File Clip Boundaries
154	RD Plot Boundary	Sheet Border Plot Boundaries
155	RD UPRR RW	UPRR RW
156	RD BNSF RW	BNSF RW
157	RD Undefined	Undefined level
158	RD Undefined	Undefined level
159	RD Undefined	Undefined level
160	RD Rdwy Sta Sys L	Roadway/Grade Separation, Station, Systems Linework
161	RD Rdwy Sta Sys A	Roadway/Grade Separation, Station, Systems Annotation
162	RD Rdwy Sta Sys H	Roadway/Grade Separation, Station, Systems Hatching
163	RD Rdwy Sta Sys NP	Roadway/Grade Separation, Station, Systems No Plot



164	RD Undefined	Undefined level
165	RD No_Plot	Data does not plot
166	RD No_Plot	Data does not plot
167	RD No_Plot	Data does not plot
168	RD No_Plot	Data does not plot
169	RD No_Plot	Data does not plot
170	RD Plot_Shape	Plot shape for IPlot - DOES NOT PLOT
171	RD Misc Map Annotation	Miscellaneous Map Annotation
172	RD Undefined	Undefined level
173	RD Undefined	Undefined level
174	RD Undefined	Undefined level
175	RD New RW L	New ROW Linework
176	RD New RW A	New ROW Annotation
177	RD New RW H	New ROW Hatching
178	RD New RW NP	New ROW No Plot
179	RD Undefined	Undefined level
180	RD New PSE L	New Permanent Surface Easement Linework
181	RD PSE A	New Permanent Surface Easement Annotation
182	RD PSE H	New Permanent Surface Easement Hatching
183	RD New PSE NP	New Permanent Surface Easement No Plot
184	RD Undefined	Undefined level
185	RD New PSSE L	New Permanent Sub-Surface Easement Linework
186	RD New PSSE A	New Permanent Sub-Surface Easement Annotation
187	RD New PSSE H	New Permanent Sub-Surface EasementHatching
188	RD New PSSE NP	New Permanent Sub-Surface Easement No Plot
189	RD Undefined	Undefined level
190	RD New AERIAL L	New Aerial Easement Linework
191	RD New AERIAL H	New Aerial Easement Hatching
192	RD New AERIAL A	New Aerial Easement Annotation
193	RD New AERIAL NP	New Aerial Easement No Plot
194	RD Undefined	Undefined level
195	RD TCE L	Temporary Construction Easement Linework
196	RD TCE A	Temporary Construction Easement Annotation
197	RD TCE H	Temporary Construction Easement Hatching
198	RD TCE NP	Temporary Construction Easement No Plot
199	RD Undefined	Undefined level
200	RD Undefined	Undefined level
201	RD Center and Station Line	Center/Station Line
202	RD Dropout	Drop Out
203	RD Dropout	Drop Out
204	RD Dropout	Drop Out
205	RD Dropout	Drop Out



206	RD Dropout	Drop Out
207	RD Dropout	Drop Out
208	RD Dropout	Drop Out
209	RD Reserved for Dist	Reserved for Dist.
210	RD Border	Border
211	RD Undefined	Undefined level
212	RD Leaders and Dim Lines	Leaders and Dim Lines
213	RD Rebar	Rebar
214	RD Text and Titles	Text and Titles
215	RD Design Notes	Design Notes
216	RD Rebar	Rebar
217	RD Rebar	Rebar
218	RD Rebar	Rebar
219	RD Rebar	Rebar
220	RD Structural Steel	Structural Steel
221	RD Structural Steel	Structural Steel
222	RD Mics Steel	Misc Steel
223	RD Existing Steel	Existing Steel
224	RD Existing Steel	Existing Steel
225	RD Existing Steel	Existing Steel
228	RD Undefined	Undefined
229	RD Undefined	Undefined
230	RD Wood	Wood
231	RD Wood	Wood
232	RD Wood	Wood
233	RD Existing Wood	Existing Wood
234	RD Existing Wood	Existing Wood
235	RD Existing Wood	Existing Wood
236	RD Minor Contours	Minor Contours
237	RD Major Contours	Major Contours
238	RD Undefined	Undefined level
239	RD Undefined	Undefined level
240	RD Concrete	Concrete
241	RD Concrete	Concrete
242	RD Concrete	Concrete
243	RD Existing Concrete	Existing Concrete
244	RD Existing Concrete	Existing Concrete
245	RD Existing Concrete	Existing Concrete
246	RD Retaining Walls	Retaining Walls
247	RD Culvert	Culvert
248	RD Undefined	Undefined level
249	RD Undefined	Undefined level



250	RD Undefined	Undefined level
251	RD Masonry	Masonry
252	RD Bridge Data	Bridge Data
253	RD Undefined	Undefined level
254	RD Undefined	Undefined level
255	RD Undefined	Undefined level
256	RD Undefined	Undefined level
257	RD Ground Line	Ground Line
258	RD Bridge Staging	Bridge Staging
259	RD Undefined	Undefined level
260	RD Undefined	Undefined level
261	RD Reserved for OE	Reserved for OE
262	RD AS-BUILT CHANGES	AS-BUILT CHANGES
263	RD Engineers Seal Signature	Engineers Seal Signature
264	RD No_Plot	Data does not plot
265	RD No_Plot	Data does not plot
266	RD No_Plot	Data does not plot
267	RD No_Plot	Data does not plot
268	RD No_Plot	Data does not plot
269	RD No_Plot	Data does not plot
270	RD Plot_Shape	Plot shape for IPlot - DOES NOT PLOT
271	RD Tunnel-Membrane1	Tunnel-Membrane1
272	RD Tunnel-Membrane2	Tunnel-Membrane2
273	RD Tunnel-Membrane3	Tunnel-Membrane3
274	RD Tunnel-Rock bolt	Tunnel-Rock bolt
275	RD Tunnel-Cable Tieback	Tunnel-Cable Tieback
276	RD Tunnel-Precast Concrete	Tunnel-Precast Concrete
277	RD Tunnel-Tunnel-Shot-crete	Tunnel-Tunnel-Shot-crete
278	RD Tunnel-Fiber Reinforced Shot-crete	Tunnel-Fiber Reinforced Shot-crete
279	RD Tunnel-Welded wire fabric	Tunnel-Welded wire fabric
280	RD Tunnel-Mastic	Tunnel-Mastic
281	RD Tunnel-Grout	Tunnel-Grout
282	RD Tunnel-Cellular grout	Tunnel-Cellular grout
283	RD Tunnel-Segment seal	Tunnel-Segment seal
284	RD Tunnel-Rubber seal	Tunnel-Rubber seal
285	RD Tunnel-Pumps	Tunnel-Pumps
286	RD Tunnel-Liner plate	Tunnel-Liner plate
287	RD Tunnel-Rock Dowel	Tunnel-Rock Dowel
288	RD Tunnel-Outline	Tunnel-Outline
289	RD Portal Siteplan	Portal Siteplan
290	RD Tunnel-Site Area	Tunnel-Site Working Area



291	RD Tunnel-Veh Assmbly Area	Tunnel-Vehicle Assembly Area
292	RD Tunnel-Ped Pathway	Tunnel-Pedestrian Pathway
293	RD Tunnel-Vent Hood	Tunnel-Ventilation Hood
294	RD Tunnel-Helo Pad	Tunnel-Helicopter Pad
295	RD Tunnel Construction Pad	Tunnel Construction Pad
296	RD Spoils	Spoils
297	RD Spoils Haul	Spoils Haul
298	RD Spoils Tunnel	Spoils Tunnel
299	RD Environmental footprint	Environmental footprint
300	RD Undefined	Undefined level
226	RD Top-Toe of fill	Top-Toe of Fill
227	RD Pattern-crosshatching	Pattern-Crosshatching
301	RD Roadway	Roadway and Stationing
302	RD Dropout	Dropout Level
303	RD Dropout	Dropout Level
304	RD Dropout	Dropout Level
305	RD Dropout	Dropout Level
306	RD Dropout	Dropout Level
307	RD Dropout	Dropout Level
308	RD Dropout	Dropout Level
309	RD Dropout	Dropout Level
310	RD Sheet Border	Sheet Border information
311	RD Dropout	Dropout Level
312	RD Dimensions	Dimensioning
313	RD Text Misc	Miscellaneous Text
314	RD Text Std	Standard Text
315	RD Text Title	Title Block Text
316	RD Text No-Plot	Non-plotting Text
317	RD Ground 1	Ground
318	RD Ground 2	Ground
319	RD Concrete 1	Concrete
320	RD Concrete 2	Concrete
321	RD Concrete 3	Concrete
322	RD CMU 1	CMU
323	RD CMU 2	CMU
324	RD CMU 3	CMU
325	RD Steel 1	Structural Steel
326	RD Steel 2	Steel
327	RD Steel 3	Steel
328	RD Metal Panels	Metal Panels
329	RD Metal Studs	Metal Studs
330	RD Metal Misc	Metal Miscellaneous



331	RD Wood 1	Wood
332	RD Wood 2	Wood
333	RD Wood 3	Wood
334	RD Gypsum Board	Gypsum Board
335	RD Plywood	Plywood
336	RD Wall Finish 1	Wall Finish Material
337	RD Wall Finish 2	Wall Finish Material
338	RD Tile 1	Tile
339	RD Tile 2	Tile
340	RD Flooring 1	Flooring Material
341	RD Flooring 2	Flooring Material
342	RD Insulation	Insulation
343	RD Ceiling Grid	Reflected Ceiling Grid
344	RD Lighting Fixtures	Lighting Fixtures electrical
345	RD HVAC	Mechanical Equipment and Registers
346	RD Doors	Doors
347	RD Windows	Windows
348	RD Plumbing	Plumbing fixtures
349	RD Furniture	Furniture
350	RD Cabinets	Cabinetry
351	RD Hidden Line	Hidden Line
352	RD Line Above	Dashed Line
353	RD Center Line	Center Line
354	RD Misc Line Wt 0	Misc Line Wt=0
355	RD Misc Line	Misc Line Wt=1
356	RD Misc Line	Misc Line Wt=0
357	RD Misc Line	Misc Line Wt=0
358	RD Misc Line	Misc Line Wt=1
359	RD Misc Line	Misc Line Wt=2
360	RD Misc Line	Misc Line Wt=4
361	RD HQ Changes	Headquarters Changes
362	RD AsBuilts	As-Built Changes
363	RD OE Use Only	OE Use
364	RD No_Plot	Data does not plot
365	RD No_Plot	Data does not plot
366	RD No_Plot	Data does not plot
367	RD No_Plot	Data does not plot
368	RD No_Plot	Data does not plot
369	RD No_Plot	Data does not plot
370	RD Plot_Shape	Plot shape for IPlot - DOES NOT PLOT
371	RD A-CLNG	Ceiling
372	RD A-CLNG-OPNG	Ceiling: Openings



373	RD A-CLNG-SUSP	Ceiling: Suspended elements
374	RD Undefined	Undefined level
375	RD A-COLS	Columns
376	RD Undefined	Undefined level
377	RD A-EQPM	Equipment
378	RD A-EQPM-FIXD	Equipment: Fixed
379	RD A-EQPM-NINN	Equipment: Not in contract (N.I.C.)
380	RD A-EQPM-OVHD	Equipment: Overhead
381	RD Undefined	Undefined level
382	RD A-FLOR-HRAL	Floor: Handrails, guard rails
383	RD A-FLOR-LEVL	Floor: Level changes, ramps, pits, depressions
384	RD A-FLOR-OTLN	Floor: Outline
385	RD Undefined	Undefined level
386	RD Undefined	Undefined level
387	RD Undefined	Undefined level
388	RD Undefined	Undefined level
389	RD Undefined	Undefined level
390	RD Undefined	Undefined level
391	RD Undefined	Undefined level
392	RD Undefined	Undefined level
393	RD Undefined	Undefined level
394	RD Undefined	Undefined level
395	RD Undefined	Undefined level
396	RD Undefined	Undefined level
397	RD Undefined	Undefined level
398	RD Undefined	Undefined level
399	RD Undefined	Undefined level
400	RD Undefined	Undefined level
401	RD Sta Lines	Roadway and Stationing
402	RD Dropout	Dropout Level
403	RD Dropout	Dropout Level
404	RD Dropout	Dropout Level
405	RD Dropout	Dropout Level
406	RD Dropout	Dropout Level
407	RD Dropout	Dropout Level
408	RD Dropout	Dropout Level
409	RD Dropout	Dropout Level
410	RD Sheet Border	Sheet Border information
411	RD Dropout	Border Dropout Information
412	RD Dimensions	Dimensioning
413	RD Reinforcement Steel	Reinforcement Steel
414	RD Text Std	Text and Detail Notes



415	RD Design Notes	Design Notes
416	RD Misc Steel	Misc Steel (plates, studs, etc)
417	RD HSS	Hollow Structural Steel
418	RD Angle Iron	Angle Iron
419	RD Channel Beam	Steel Channels
420	RD Wide Flange	Steel Wide Flange
421	RD Misc Steel	Misc Steel (plates, studs, etc)
422	RD Cold Form Stl	Metal Wall Studs and Joists
423	RD Steel Grates	Steel Grates
424	RD Steel Decking	Structural Steel Decking
425	RD Conduit and Piping	Conduit and Piping
426	RD Elec Mech	Electrical and Mechanical Equipment
427	RD Plumb Elec	Plumbing Diagramas Electric Schematics
428	RD Exist Elec Mech	Existing Electric Mechanical Equip
429	RD Elec Mech	Electrical and Mechanical
430	RD Wood 1	Wood Floor Framing or Loft
431	RD Wood 2	Wood Wall Framing
432	RD Wood 3	Wood Framing Ceiling
433	RD Wood 4	Wood Laminated Beams
434	RD Sheathing	Sheathing
435	RD Blocking 1	Blocking
436	RD Blocking 2	Blocking
437	RD Undefined	Undefined level
438	RD Undefined	Undefined level
439	RD Undefined	Undefined level
440	RD Conc Slab Wall	Concrete Slab or Walls
441	RD Conc Footing	Concrete Footings
442	RD Conc Pile	Concrete Piles
443	RD Conc Col	Concrete Columns
444	RD Conc Masonry	Concrete Masonry
445	RD Conc Pattern	Concrete Pattern
446	RD Original Ground	Original Ground
447	RD Sand	Sand Pattern
448	RD Aggregate	Free Draining Granular Material
449	RD Undefined	Undefined level
450	RD Undefined	Undefined level
451	RD Undefined	Undefined level
452	RD Undefined	Undefined level
453	RD Undefined	Undefined level
454	RD Undefined	Undefined level
455	RD Undefined	Undefined level
456	RD Undefined	Undefined level



457	RD Undefined	Undefined level
458	RD Undefined	Undefined level
459	RD Plot	Reserved For Special Plot
460	RD UBC Code	Non Plotting Text
461	RD HQ Changes	Headquarters Changes
462	RD AsBuilts	As-Built Changes
463	RD OE Use Only	OE Use
464	RD No_Plot	Data does not plot
465	RD No_Plot	Data does not plot
466	RD No_Plot	Data does not plot
467	RD No_Plot	Data does not plot
468	RD No_Plot	Data does not plot
469	RD No_Plot	Data does not plot
470	RD Plot_Shape	Plot shape for IPlot - DOES NOT PLOT
471	RD Undefined	Undefined level
472	RD Undefined	Undefined level
473	RD Undefined	Undefined level
474	RD Undefined	Undefined level
475	RD Undefined	Undefined level
476	RD Undefined	Undefined level
477	RD Undefined	Undefined level
478	RD Undefined	Undefined level
479	RD Undefined	Undefined level
480	RD Undefined	Undefined level
481	RD Undefined	Undefined level
482	RD Undefined	Undefined level
483	RD Undefined	Undefined level
484	RD Undefined	Undefined level
485	RD Undefined	Undefined level
486	RD Undefined	Undefined level
487	RD Undefined	Undefined level
488	RD Undefined	Undefined level
489	RD Undefined	Undefined level
490	RD Undefined	Undefined level
491	RD Undefined	Undefined level
492	RD Undefined	Undefined level
493	RD Undefined	Undefined level
494	RD Undefined	Undefined level
495	RD Undefined	Undefined level
496	RD Undefined	Undefined level
497	RD Undefined	Undefined level
498	RD Undefined	Undefined level



499	RD Undefined	Undefined level
500	RD Undefined	Undefined level
501	RD Sta Lines	Roadway and Stationing
502	RD (E) Building Outline	Existing Building Outline
503	RD (E) Fixtures and Equipment	(E) Fixt./Equipment
504	RD Dropout	Dropout Level
505	RD Dropout	Dropout Level
506	RD Dropout	Dropout Level
507	RD Dropout	Dropout Level
508	RD Dropout	Dropout Level
509	RD Dropout	Dropout Level
510	RD Sheet Border	Sheet Border information
511	RD Dropout	Border Dropout Information
512	RD Dimensions	Dimensioning
513	RD Reinforcement Steel	Reinforcement Steel
514	RD Text Std	Text and Detail Notes
515	RD Design Notes	Design Notes
516	RD Misc Steel	Misc Steel (plates, studs, etc)
517	RD HSS	Hollow Structural Steel
518	RD Angle Iron	Angle Iron
519	RD Channel Beam	Steel Channels
520	RD Wide Flange	Steel Wide Flange
521	RD Misc Steel	Misc Steel (plates, studs, etc)
522	RD Cold Form Steel	Metal Wall Studs and Joists
523	RD Steel Grates	Steel Grates
524	RD Steel Decking	Structural Steel Decking
525	RD Conduit and Piping	Conduit and Piping
526	RD Elec Mech	Electrical and Mechanical Equipment
527	RD Plumb Elec	Plumbing Diagramas Electric Schematics
528	RD Exist Elec Mech	Existing Electric Mechanical Equip
529	RD Plumb Mech	Plumbing Diagramas Mech Schematics
530	RD Wood 1	Wood Floor Framing or Loft
531	RD Wood 2	Wood Wall Framing
532	RD Wood 3	Wood Framing Ceiling
533	RD Wood 4	Wood Laminated Beams
534	RD Sheathing	Sheathing
535	RD Blocking 1	Blocking
536	RD Blocking 2	Blocking
537	RD Supply Air	Supply Air Duct HVAC
538	RD Return Air	Return Air Duct HVAC
539	RD Exhaust Air	Exhaust Air Duct HVAC
540	RD Conc Slab	Concrete Slab or Walls



541	RD Conc Footing	Concrete Footings
542	RD Conc Pile	Concrete Piles
543	RD Conc Column	Concrete Columns
544	RD Conc Masonry	Concrete Masonry
545	RD Conc Pattern	Concrete Pattern
546	RD Original Ground	Original Ground
547	RD Sand	Sand Pattern
548	RD Aggregate	Free Draining Granular Material
549	RD Cold Water	Cold Water (tees, elbows, unions, & valves)
550	RD Hot Water	Hot Water (tees, elbows, unions, & valves)
551	RD Sewer Line	Sewer Line (ptraps, cleanouts, & floor drains)
552	RD Fire Service	Fire Protection Water Service Line
553	RD Air Line	Compressed Air Line
554	RD Vent Line	Sewer Vent Lines
555	RD Gas Line	Gas Service Line (NG, LPG)
556	RD Drain Line	Drain Line (rood, trench drains, & condensate)
557	RD Relief Line	Relief Line (water heater relief line)
558	RD Mech Equipment	Mechanical Fixtures/Equipment
559	RD Undefined	Undefined
560	RD UBC Code	Non Plotting Text
561	RD HQ Changes	Headquarters Changes
562	RD AsBuilts	As-Built Changes
563	RD OE Use Only	OE Use
564	RD No_Plot	Data does not plot
565	RD No_Plot	Data does not plot
566	RD No_Plot	Data does not plot
567	RD No_Plot	Data does not plot
568	RD No_Plot	Data does not plot
569	RD No_Plot	Data does not plot
570	RD Plot_Shape	Plot shape for IPlot - DOES NOT PLOT
571	RD Undefined	Undefined level
572	RD Undefined	Undefined level
573	RD Undefined	Undefined level
574	RD Undefined	Undefined level
575	RD Undefined	Undefined level
576	RD Undefined	Undefined level
577	RD Undefined	Undefined level
578	RD Undefined	Undefined level
579	RD Undefined	Undefined level
580	RD Undefined	Undefined level
581	RD Undefined	Undefined level
582	RD Undefined	Undefined level



583	RD Undefined	Undefined level
584	RD Undefined	Undefined level
585	RD Undefined	Undefined level
586	RD Undefined	Undefined level
587	RD Undefined	Undefined level
588	RD Undefined	Undefined level
589	RD Undefined	Undefined level
590	RD Undefined	Undefined level
591	RD Undefined	Undefined level
592	RD Undefined	Undefined level
593	RD Undefined	Undefined level
594	RD Undefined	Undefined level
595	RD Undefined	Undefined level
596	RD Undefined	Undefined level
597	RD Undefined	Undefined level
598	RD Undefined	Undefined level
599	RD Undefined	Undefined level
600	RD Undefined	Undefined level
601	RD Sta Lines	Roadway and Stationing
602	RD Dropout	Dropout Level
603	RD Dropout	Dropout Level
604	RD Dropout	Dropout Level
605	RD Dropout	Dropout Level
606	RD Dropout	Dropout Level
607	RD Dropout	Dropout Level
608	RD Dropout	Dropout Level
609	RD Dropout	Dropout Level
610	RD Sheet Border	Sheet Border information
611	RD Dropout	Border Dropout Information
612	RD Dimensions	Dimensioning
613	RD Reinforcement Steel	Reinforcement Steel
614	RD Text Std	Text and Detail Notes
615	RD Design Notes	Design Notes
616	RD Misc Steel	Misc Steel (plates, studs, etc)
617	RD HSS	Hollow Structural Steel
618	RD Angle Iron	Angle Iron
619	RD Channel Beam	Steel Channels
620	RD Wide Flange	Steel Wide Flange
621	RD Misc Steel	Misc Steel (plates, studs, etc)
622	RD Cold Form Steel	Metal Wall Studs and Joists
623	RD Steel Grates	Steel Grates
624	RD Steel Decking	Structural Steel Decking



625	RD Conduit and Piping	Conduit and Piping
626	RD Elec Mech	Electrical and Mechanical Equipment
627	RD Plumb Elec	Plumbing Diagrams, Electric Schematics
628	RD Exist Elec Mech	Existing Electric Mechanical Equip
629	RD Elec Mech	Electrical and Mechanical Misc Level
630	RD Wood 1	Wood Floor Framing or Loft
631	RD Wood 2	Wood Wall Framing
632	RD Wood 3	Wood Framing Ceiling
633	RD Wood 4	Wood Laminated Beams
634	RD Sheathing	Sheathing
635	RD Blocking 1	Blocking
636	RD Blocking 2	Blocking
637	RD Undefined	Undefined level
638	RD Undefined	Undefined level
639	RD Undefined	Undefined level
640	RD Conc Slab	Concrete Slab or Walls
641	RD Conc Footing	Concrete Footings
642	RD Conc Pile	Concrete Piles
643	RD Conc Column	Concrete Columns
644	RD Conc Masonry	Concrete Masonry
645	RD Conc Pattern	Concrete Pattern
646	RD Original Ground	Original Ground
647	RD Sand	Sand Pattern
648	RD Aggregate	Free Draining Granular Material
649	RD Sewage Pipe	Sewage Pipe
650	RD Drain + Vent	Drain + Vent
651	RD Potable Water	Potable Water
652	RD Raw Water	Raw Water
653	RD Leach Line	Leach Line
654	RD Pumps and Valves	Pumps & Valves
655	RD Tanks	Tanks
656	RD Equipment Below	Equipment Below
657	RD Equipment Above	Equipment Above
658	RD Wells	Wells
659	RD Plot	Reserved For Special Plot
660	RD UBC Code	Non Plotting Text
661	RD HQ Changes	Headquarters Changes
662	RD AsBuilts	As-Built Changes
663	RD OE Use Only	OE Use
664	RD No_Plot	Data does not plot
665	RD No_Plot	Data does not plot
666	RD No_Plot	Data does not plot



667	RD No_Plot	Data does not plot
668	RD No_Plot	Data does not plot
669	RD No_Plot	Data does not plot
670	RD Plot_Shape	Plot shape for IPlot - DOES NOT PLOT
671	RD Undefined	Undefined level
672	RD Undefined	Undefined level
673	RD Undefined	Undefined level
674	RD Undefined	Undefined level
675	RD Undefined	Undefined level
676	RD Undefined	Undefined level
677	RD Undefined	Undefined level
678	RD Undefined	Undefined level
679	RD Undefined	Undefined level
680	RD Undefined	Undefined level
681	RD Undefined	Undefined level
682	RD Undefined	Undefined level
683	RD Undefined	Undefined level
684	RD Undefined	Undefined level
685	RD Undefined	Undefined level
686	RD Undefined	Undefined level
687	RD Undefined	Undefined level
688	RD Undefined	Undefined level
689	RD Undefined	Undefined level
690	RD Undefined	Undefined level
691	RD Undefined	Undefined level
692	RD Undefined	Undefined level
693	RD Undefined	Undefined level
694	RD Undefined	Undefined level
695	RD Undefined	Undefined level
696	RD Undefined	Undefined level
697	RD Undefined	Undefined level
698	RD Undefined	Undefined level
699	RD Undefined	Undefined level
700	RD Undefined	Undefined level
701	RD Sta Lines	Roadway and Stationing
702	RD Dropout	Dropout Level
703	RD Dropout	Dropout Level
704	RD Dropout	Dropout Level
705	RD Dropout	Dropout Level
706	RD Dropout	Dropout Level
707	RD Dropout	Dropout Level
708	RD Dropout	Dropout Level



709	RD Dropout	Dropout Level
710	RD Sheet Border	Sheet Border information
711	RD Dropout	Border Dropout Information
712	RD Dimensions	Dimensioning
713	RD Reinforcement Steel	Reinforcement Steel
714	RD Text Std	Text and Detail Notes
715	RD Design Notes	Design Notes
716	RD Misc Steel	Misc Steel (plates, studs, etc)
717	RD HSS	Hollow Structural Steel
718	RD Angle Iron	Angle Iron
719	RD Channel Beam	Steel Channels
720	RD Wide Flange	Steel Wide Flange
721	RD Misc Steel	Misc Steel (plates, studs, etc)
722	RD Cold Form Steel	Metal Wall Studs and Joists
723	RD Steel Grates	Steel Grates
724	RD Steel Decking	Structural Steel Decking
725	RD Conduit and Piping	Conduit and Piping
726	RD Elec Mech	Electrical and Mechanical Equipment
727	RD Plumb Elec	Plumbing Diagrams, Electric Schematics
728	RD Exist Elec Mech	Existing Electric Mechanical Equip
729	RD Elec Mech	Electrical and Mechanical Misc Level
730	RD Wood 1	Wood Floor Framing or Loft
731	RD Wood 2	Wood Wall Framing
732	RD Wood 3	Wood Framing Ceiling
733	RD Wood 4	Wood Laminated Beams
734	RD Sheathing	Sheathing
735	RD Blocking 1	Blocking
736	RD Blocking 2	Blocking
737	RD Undefined	Undefined level
738	RD Undefined	Undefined level
739	RD Undefined	Undefined level
740	RD Conc Slab	Concrete Slab or Walls
741	RD Conc Footing	Concrete Footings
742	RD Conc Pile	Concrete Piles
743	RD Conc Column	Concrete Columns
744	RD Conc Masonry	Concrete Masonry
745	RD Conc Pattern	Concrete Pattern
746	RD Original Ground	Original Ground
747	RD Sand	Sand Pattern
748	RD Aggregate	Free Draining Granular Material
749	RD Sewage Pipe	Sewage Pipe
750	RD Drain + Vent	Drain + Vent



751	RD Potable Water	Potable Water
752	RD Raw Water	Raw Water
753	RD Leach Line	Leach Line
754	RD Pumps and Valves	Pumps & Valves
755	RD Tanks	Tanks
756	RD Equipment Below	Equipment Below
757	RD Equipment Above	Equipment Above
758	RD Wells	Wells
759	RD Plot	Reserved For Special Plot
760	RD UBC Code	Non Plotting Text
761	RD HQ Changes	Headquarters Changes
762	RD AsBuilts	As-Built Changes
763	RD OE Use Only	OE Use
764	RD No_Plot	Data does not plot
765	RD No_Plot	Data does not plot
766	RD No_Plot	Data does not plot
767	RD No_Plot	Data does not plot
768	RD No_Plot	Data does not plot
769	RD No_Plot	Data does not plot
770	RD Plot_Shape	Plot shape for IPlot - DOES NOT PLOT
771	RD Undefined	Undefined level
772	RD Undefined	Undefined level
773	RD Undefined	Undefined level
774	RD Undefined	Undefined level
775	RD Undefined	Undefined level
776	RD Undefined	Undefined level
777	RD Undefined	Undefined level
778	RD Undefined	Undefined level
779	RD Undefined	Undefined level
780	RD Undefined	Undefined level
781	RD Undefined	Undefined level
782	RD Undefined	Undefined level
783	RD Undefined	Undefined level
784	RD Undefined	Undefined level
785	RD Undefined	Undefined level
786	RD Undefined	Undefined level
787	RD Undefined	Undefined level
788	RD Undefined	Undefined level
789	RD Undefined	Undefined level
790	RD Undefined	Undefined level
791	RD Undefined	Undefined level
792	RD Undefined	Undefined level



793	RD Undefined	Undefined level
794	RD Undefined	Undefined level
795	RD Undefined	Undefined level
796	RD Undefined	Undefined level
797	RD Undefined	Undefined level
798	RD Undefined	Undefined level
799	RD Undefined	Undefined level
800	RD Undefined	Undefined level
801	RD Undefined	Undefined level
802	RD Dropout	Dropout
803	RD Dropout	Dropout
804	RD Dropout	Dropout
805	RD Dropout	Dropout
806	RD Dropout	Dropout
807	RD Dropout	Dropout
808	RD Dropout	Dropout
809	RD Dropout	Dropout
810	RD Undefined	Undefined level
811	RD Undefined	Undefined level
812	RD ut-elec-p	ut-elec-p
813	RD ut-elec-x	ut-elec-x
814	RD ut-gas-p	ut-gas-p
815	RD ut-gas-x	ut-gas-x
816	RD ut-natgas-p	ut-natgas-p
817	RD ut-natgas-x	ut-natgas-x
818	RD ut-oil-p	ut-oil-p
819	RD ut-oil-x	ut-oil-x
820	RD ut-sewer-p	ut-sewer-p
821	RD ut-sewer-x	ut-sewer-x
822	RD ut-steam-p	ut-steam-p
823	RD ut-steam-x	ut-steam-x
824	RD ut-stormD-p	ut-stormD-p
825	RD ut-stormD-x	ut-stormD-x
826	RD ut-telecom-p	ut-telecom-p
827	RD ut-telecom-x	ut-telecom-x
828	RD ut-teleph-p	ut-teleph-p
829	RD ut-teleph-x	ut-teleph-x
830	RD ut-tv-p	ut-tv-p
831	RD ut-tv-x	ut-tv-x
832	RD ut-water-p	ut-water-p
833	RD ut-water-x	ut-water-x
834	RD tr-fiberopt-p	tr-fiberopt-p



835	RD tr-fiberopt-x	tr-fiberopt-x
836	RD ut-elec-oh-p	ut-elec-oh-p
837	RD ut-elec-oh-x	ut-elec-oh-x
838	RD ut-telecom-oh-p	ut-telecom-oh-p
839	RD ut-telecom-oh-x	ut-telecom-oh-x
840	RD ut-telep-oh-p	ut-telep-oh-p
841	RD ut-telep-oh-x	ut-telep-oh-x
842	RD ut-tv-oh-p	ut-tv-oh-p
843	RD ut-tv-oh-x	ut-tv-oh-x
844	RD ut-fiberopt-oh-p	ut-fiberopt-oh-p
845	RD ut-fiberopt-oh-x	ut-fiberopt-oh-x
846	RD Undefined	Undefined level
847	RD Undefined	Undefined level
848	RD Undefined	Undefined level
849	RD Undefined	Undefined level
850	850 Staging-Overall Outline	
851	851 Staging-Area Layout	
852	852 Staging-Road Close	
853	RD Undefined	Undefined level
854	RD Undefined	Undefined level
855	RD Undefined	Undefined level
856	RD Undefined	Undefined level
857	RD Undefined	Undefined level
858	RD Undefined	Undefined level
859	RD Undefined	Undefined level
860	RD Undefined	Undefined level
861	RD Undefined	Undefined level
862	RD Undefined	Undefined level
863	RD Undefined	Undefined level
864	RD No_Plot	Data does not plot
865	RD No_Plot	Data does not plot
866	RD No_Plot	Data does not plot
867	RD No_Plot	Data does not plot
868	RD No_Plot	Data does not plot
869	RD No_Plot	Data does not plot
870	RD Plot_Shape	Plot shape for IPlot - DOES NOT PLOT
871	RD Staging Dropout	Staging Dropout
872	RD Staging Dropout	Staging Dropout
873	RD Staging Dropout	Staging Dropout
874	RD Staging Dropout	Staging Dropout
875	RD Staging Dropout	Staging Dropout
876	RD Staging Dropout	Staging Dropout



877	RD Staging Dropout	Staging Dropout
878	RD Staging Dropout	Staging Dropout
879	RD Staging Dropout	Staging Dropout
880	RD Staging Dropout	Staging Dropout
881	RD Staging Dropout	Staging Dropout
882	RD Staging Dropout	Staging Dropout
883	RD Staging Dropout	Staging Dropout
884	RD Staging Dropout	Staging Dropout
885	RD Staging Dropout	Staging Dropout
886	RD Staging Dropout	Staging Dropout
887	RD Staging Dropout	Staging Dropout
888	RD Staging Dropout	Staging Dropout
889	RD Staging Dropout	Staging Dropout
890	RD Staging Dropout	Staging Dropout
891	RD Striping Dropout	Striping Dropout
892	RD Striping Dropout	Striping Dropout
893	RD Striping Dropout	Striping Dropout
894	RD Striping Dropout	Striping Dropout
895	RD Striping Dropout	Striping Dropout
896	RD Miscellaneous Dropout	Miscellaneous Dropout
897	RD Miscellaneous Dropout	Miscellaneous Dropout
898	RD Miscellaneous Dropout	Miscellaneous Dropout
899	RD Miscellaneous Dropout	Miscellaneous Dropout
900	RD Miscellaneous Dropout	Miscellaneous Dropout
901	RD Control A	Layout Lines Center Lines
902	RD Control B	Layout Lines Center Lines
903	RD Bar Chart A	Rebar Bar Chart Graphics
904	RD Bar Chart B	Rebar Bar Chart Graphics
905	RD Bar Chart C	Rebar Bar Chart Content
906	RD Bar Chart D	Rebar Bar Chart Content
907	RD Undefined	Undefined level
908	RD Undefined	Undefined level
909	RD Bentley Source	Bentley Supplied Content
910	RD Sheet Format	Border Contents(Includes North Arrow)
911	RD Hatching	Various Patterns
912	RD Dimensions	Dim Lines &Arrows
913	RD Warnings	Warning Messages
914	RD Text	Notes Leaders & Arrows
915	RD Reinf (Default)	Reinforcement (Default)
916	RD Reinf Top A	Reinforcement Top Layer
917	RD Reinf Top B	Reinforcement Top Layer
918	RD Reinf Top C	Reinforcement Top Layer



919	RD Reinf Top D	Reinforcement Top Layer
920	RD Reinf Top E	Reinforcement Top Layer
921	RD Reinf Top F	Reinforcement Top Layer
922	RD Reinf Top G	Reinforcement Top Layer
923	RD Reinf Top H	Reinforcement Top Layer
924	RD Reinf Top I	Reinforcement Top Layer
925	RD Reinf Top J	Reinforcement Top Layer
926	RD Reinf Top K	Reinforcement Top Layer
927	RD Reinf Top L	Reinforcement Top Layer
928	RD Reinf Bot A	Reinforcement Bot Layer
929	RD Reinf Bot B	Reinforcement Bot Layer
930	RD Reinf Bot C	Reinforcement Bot Layer
931	RD Reinf Bot D	Reinforcement Bot Layer
932	RD Reinf Bot E	Reinforcement Bot Layer
933	RD Reinf Bot F	Reinforcement Bot Layer
934	RD Reinf Bot G	Reinforcement Bot Layer
935	RD Reinf Bot H	Reinforcement Bot Layer
936	RD Reinf Bot I	Reinforcement Bot Layer
937	RD Reinf Bot J	Reinforcement Bot Layer
938	RD Reinf Bot K	Reinforcement Bot Layer
939	RD Reinf Bot L	Reinforcement Bot Layer
940	RD Concrete Face A	Plans Sections Elevations
941	RD Concrete Face B	Plans Sections Elevations
942	RD Concrete Face C	Plans Sections Elevations
943	RD Concrete Face D	Plans Sections Elevations
944	RD Concrete Face E	Plans Sections Elevations
945	RD Concrete Face F	Plans Sections Elevations
946	RD Concrete Face G	Plans Sections Elevations
947	RD Concrete Face H	Plans Sections Elevations
948	RD Concrete Face I	Plans Sections Elevations
949	RD Concrete Face J	Plans Sections Elevations
950	RD Concrete Face K	Plans Sections Elevations
951	RD Concrete Face L	Plans Sections Elevations
952	RD Concrete Face M	Plans Sections Elevations
953	RD Concrete Face N	Plans Sections Elevations
954	RD Concrete Face O	Plans Sections Elevations
955	RD Concrete Face P	Plans Sections Elevations
956	RD Tendons A	Strands Ducts Anchorages
957	RD Tendons B	Strands Ducts Anchorages
958	RD Tendons C	Strands Ducts Anchorages
959	RD Structural Steel A	Plates Angles Shapes Tubes
960	RD Structural Steel B	Plates Angles Shapes Tubes



961	RD Structural Steel C	Plates Angles Shapes Tubes
962	RD Devices A	Bearings Anchorages Restrainers
963	RD Devices B	Bearings Anchorages Restrainers
964	RD Reserved A	RD Reserved A
965	RD Reserved B	RD Reserved B
966	RD Stage 4	Stage 4 Const &Temp Traffic
967	RD Stage 4 Anno	Stage 4 Const &Temp Traffic Anno
968	RD Stage 5	Stage 5 Const &Temp Traffic
969	RD Stage 5 Anno	Stage 5 Const &Temp Traffic Anno
970	RD Stage 6	Stage 6 Const &Temp Traffic
971	RD Stage 6 Anno	Stage 6 Const &Temp Traffic Anno
972	RD Stage 7	Stage 7 Const &Temp Traffic
973	RD Stage 7 Anno	Stage 7 Const &Temp Traffic Anno
974	RD Stage 8	Stage 8 Const &Temp Traffic
975	RD Stage 8 Anno	Stage 8 Const &Temp Traffic Anno
976	RD Stage 9	Stage 9 Const &Temp Traffic
977	RD Stage 9 Anno	Stage 9 Const &Temp Traffic Anno
978	RD Stage 10	Stage 10 Const &Temp Traffic
979	RD Stage 10 Anno	Stage 10 Const &Temp Traffic Anno
980	RD Stage 11	Stage 11 Const &Temp Traffic
981	RD Stage 11 Anno	Stage 11 Const &Temp Traffic Anno
982	RD Stage 12	Stage 12 Const &Temp Traffic
983	RD Stage 12 Anno	Stage 12 Const &Temp Traffic Anno
984	RD Stage 13	Stage 13 Const &Temp Traffic
985	RD Stage 13 Anno	Stage 13 Const &Temp Traffic Anno
986	RD Stage 14	Stage 14 Const &Temp Traffic
987	RD Stage 14 Anno	Stage 14 Const &Temp Traffic Anno
988	RD Stage 15	Stage 15 Const &Temp Traffic
989	RD Stage 15 Anno	Stage 15 Const &Temp Traffic Anno
990	RD Stage 16	Stage 16 Const &Temp Traffic
991	RD Stage 16 Anno	Stage 16 Const &Temp Traffic Anno
992	RD Stage 17	Stage 17 Const &Temp Traffic
993	RD Stage 17 Anno	Stage 17 Const &Temp Traffic Anno
994	RD Stage 18	Stage 18 Const &Temp Traffic
995	RD Stage 18 Anno	Stage 18 Const &Temp Traffic Anno
996	RD Stage 19	Stage 19 Const &Temp Traffic
997	RD Stage 19 Anno	Stage 19 Const &Temp Traffic Anno
998	RD Stage 20	Stage 20 Const &Temp Traffic
999	RD Stage 20 Anno	Stage 20 Const &Temp Traffic Anno
1000	TT Undefined	Open
1001	TT Control	(Includes Survey Monuments)
1002	TT Dropout	Open



1003	TT Dropout	Open
1004	TT Dropout	Open
1005	TT Dropout	Open
1006	TT Dropout	Open
1007	TT Dropout	Open
1008	TT Dropout	Open
1009	TT-PROF-GRID	Track Profile Grid
1010	TT Sheet Format	(Includes North Arrow)
1011	TT Undefined	Open
1012	TT-GENR-DIMS	Leaders and Dim Lines
1013	TT-GENR-MISC-TEXT	Miscellaneous Text
1014	TT-GENR-STND-TEXT	Standard Text
1015	TT-GENR-TITL-TEXT	Title Text
1016	TT-GENR-NPLT-TEXT	Non-plotting Text
1017	TT-ALGN-NRTH-LINE	Main Northbound Alignment Data
1018	TT-ALGN-NRTH- ANNO	Main Northbound Alignment Annotation
1019	TT-ALGN-SOUT-LINE	Main Southbound Alignment Data
1020	TT-ALGN-SOUT-ANNO	Main Southbound Alignment Annotation
1021	TT-ALGN-SPUR-LINE	Spur Alignment Data
1022	TT-ALGN-SPUR-ANNO	Spur Alignment Annotation
1023	TT-RAIL-XOVR-LINE	Railroad Crossovers
1024	TT-RAIL-XOVR-ANNO	Railroad Crossovers Annotation
1025	TT-PROF-FGLT	Track Profile Finish Grade Offset Left
1026	TT-PROF-FGRT	Track Profile Finish Grade Offset Right
1027	TT-PROF-EGCL	Track Profile Existing Ground Centerline
1028	TT-PROF-EGCL-ANNO	Track Profile Existing Ground Centerline Text
1029	TT-PROF-EGLT	Track Profile Existing Ground Offset Left
1030	TT-PROF-EGLT-ANNO	Track Profile Existing Ground Left Station Text
1031	TT-PROF-EGRT	Track Profile Existing Ground Offset Right
1032	TT-PROF-EGRT-ANNO	Track Profile Existing Ground Right Station Text
1033	TT-PROF-FGCL	Track Profile Finish Grade Centerline
1034	TT-PROF-FGCL-ANNO	Track Profile Finish Grade Centerline Text
1035	TT-ALGN-STEQ-LABL	Track Station Equations
1036	TT-ALGN-STPT-LABL	Track Station Points
1037	TT EX RR ALIGNMENTS	Ex Freight & Commuter Rail Alignments
1038	TT REALIGNMENT OF EX RR	New Alignments for Ex RR
1039	TT REALIGNMENT OF EX RR ANNO	New Alignments for Ex RR ANNOTATION
1040	TT-RAIL-TIES	TIES FOR HST
1041	TT-RAIL-SWTH	HST SWITCHES
1042	TT RR Hardware	RR Hardware
1043	TT Undefined	Undefined level
1044	TT Undefined	Undefined level



1045	TT Undefined	Undefined level
1046	TT Undefined	Undefined level
1047	TT Undefined	Undefined level
1048	TT Undefined	Undefined level
1049	TT Undefined	Undefined level
1050	TT Undefined	Undefined level
1051	TT Undefined	Undefined level
1052	TT Undefined	Undefined level
1053	TT Undefined	Undefined level
1054	TT Undefined	Undefined level
1055	TT Undefined	Undefined level
1056	TT Undefined	Undefined level
1057	TT Undefined	Undefined level
1058	TT Undefined	Undefined level
1059	TT Undefined	Undefined level
1060	TT Nongeo Data	Nongeographical Drawing Data
1061	TT Undefined	Undefined level
1062	TT Undefined	Undefined level
1063	TT Undefined	Undefined level
1064	TT Undefined	Undefined level
1065	TT Undefined	Undefined level
1066	TT Undefined	Undefined level
1067	TT Undefined	Undefined level
1068	TT Undefined	Undefined level
1069	TT Undefined	Undefined level
1070	TT Undefined	Undefined level
1071	TT Undefined	Undefined level
1072	TT Undefined	Undefined level
1073	TT Undefined	Undefined level
1074	TT Undefined	Undefined level
1075	TT Undefined	Undefined level
1076	TT Undefined	Undefined level
1077	TT Undefined	Undefined level
1078	TT Undefined	Undefined level
1079	TT Undefined	Undefined level
1080	TT Undefined	Undefined level
1081	TT Undefined	Undefined level
1082	TT Undefined	Undefined level
1083	TT Undefined	Undefined level
1084	TT Undefined	Undefined level
1085	TT Undefined	Undefined level
1086	TT Undefined	Undefined level



1087	TT Undefined	Undefined level
1088	TT Undefined	Undefined level
1089	TT Undefined	Undefined level
1090	TT Undefined	Undefined level
1091	TT Undefined	Undefined level
1092	TT Undefined	Undefined level
1093	TT Undefined	Undefined level
1094	TT Undefined	Undefined level
1095	TT Undefined	Undefined level
1096	TT Undefined	Undefined level
1097	TT Undefined	Undefined level
1098	TT Undefined	Undefined level
1099	TT Undefined	Undefined level
1100	TT Undefined	Undefined level
1101	TP Control	(Includes Survey Monuments)
1102	TP Dropout	Dropout
1103	TP Dropout	Dropout
1104	TP Dropout	Dropout
1105	TP Dropout	Dropout
1106	TP Dropout	Dropout
1107	TP Dropout	Dropout
1108	TP Dropout	Dropout
1109	TP Dropout	RR Profile Grid
1110	TP Sheet	(Includes North Arrow)
1111	TP Undefined	Open
1112	TP Dimensions	Text wt & color set to bylevel
1113	TP GEN SUBTITLE	Text-General Subtitle
1114	TP GEN NOTE	text for general notes - legends - misc. info
1115	TP GEN TITLE	text for general notes - titles
1116	TP FEAT-MISC	miscellaneous
1117	TP CENTER LINE	Center Line
1118	TP DETAIL-CENTER-LINES0	Center Lines Details Weight 0
1119	TP DETAIL-HIDDEN-LINES0	Hidden Lines Details Weight 0
1120	TP DETAIL-OBJECT-LINES0	Object Lines For Details Weight 0
1121	TP DETAIL-OBJECT-LINES1	Object Lines For Details Weight 1
1122	TP DETAIL-OBJECT-LINES2	Object Lines For Details Weight 2
1123	TP DETAIL-OBJECT-LINES3	Object Lines For Details Weight 3
1124	TP DIMENSION LINE	Dimension Line
1125	TP EXISTING HIDDEN LINE	Existing Hidden Line
1126	TP EXISTING LINE	Existing Line
1127	TP PATTERN LINE	Pattern Line
1128	TP PRIMARY TABLE LINE	Primary Table Line



1129	TP PROPOSED HIDDEN LINE	Proposed Hidden Line
1130	TP PROPOSED LINE	Proposed Line
1131	TP SECONDARY TABLE LINE	Secondary Table Line
1132	TP SWITCH	
1133	TP 20 DUCT UG	Rail - Traction Power - 20" Duct Bank
1134	TP 24 DUCT UG	Rail - Traction Power - 24" Duct Bank
1135	TP 32 DUCT UG	Rail - Traction Power - 32" Duct Bank
1136	TP 40 DUCT UG	Rail - Traction Power - 40" Duct Bank
1137	TP EQUIP	Rail- Traction Power - 480V PO & Control Sta
1138	TP HANDHOLE	Rail - Traction Power - Handhole
1139	TP LINE OH	Rail - Traction Power - O/H Line
1140	TP MANHOLE	Rail - Traction Power - Manhole
1141	TP SS	Rail - Traction Power - Substation
1142	TP SWS	Rail - Traction Power - Switching Station
1143	TP PS	Rail - Traction Power - Paralleling Station
1144	TP TRANSFORMER	TP TRANSFORMER
1145	TP AUTOTRANSFORMER	TP AUTOTRANSFORMER
1146	TP AUXILIARY TRANSFORMER	TP AUXILIARY TRANSFORMER
1147	TP CONTROL ROOM	TP CONTROL ROOM
1148	TP SWITCHGEAR	TP SWITCHGEAR
1149	TP ENCLOSURE	TP ENCLOSURE
1150	TP CIRCUIT BREAKER	TP CIRCUIT BREAKER
1151	TP DISCONNECT SWITCH	TP DISCONNECT SWITCH
1152	TP RELAY	TP RELAY
1153	TP RELAY LINE	TP RELAY LINE
1154	TP CONNECTION	TP CONNECTION
1155	TP POWER LINE	TP POWER LINE
1156	TP INSULATOR	TP INSULATOR
1157	TP NEUTRAL RETURN	TP NEUTRAL RETURN
1158	TP POSITIVE FEEDER	TP POSITIVE FEEDER
1159	TP NEGATIVE FEEDER	TP NEGATIVE FEEDER
1160	TP BUS	TP BUS
1161	TP CATENARY	TP CATENARY
1162	TP TRACK	TP TRACK
1163	TP WALL	TP WALL
1164	TP SYMBOLS	TP SYMBOLS
1165	TP FENCE	TP FENCE
1166	TP GROUNDING	TP GROUNDING
1167	TP PLATFORM	TP PLATFORM
1168	TP DOOR	TP DOOR
1169	TP STRUCTURE	TP STRUCTURE
1170	TP FIREWALL	TP FIREWALL



1171	TP SCADA INTERFACE PANEL	TP SCADA INTERFACE PANEL
1172	TP HATCH	TP HATCH
1173	TP RESERVED SPASE	TP RESERVED SPASE
1174	TP CAHSR LINE	TP CAHSR LINE
1175	TP CAHSR CP	TP CAHSR CP
1176	TP CALTRAIN LINE	TP CALTRAIN LINE
1177	TP CALTRAIN CP	TP CALTRAIN CP
1178	TP CALTRAIN TEXT	TP CALTRAIN TEXT
1179	TP RAILROAD	TP RAILROAD
1180	TP CATENARY	TP CATENARY
1181	TP GANTRY	TP GANTRY
1182	TP CONDUIT	TP CONDUIT
1183	TP CONDUIT UNDERGROUND	TP CONDUIT UNDERGROUND
1184	TP SECTION	TP SECTION
1185	TP ROAD	TP ROAD
1186	TP ARST	TP ARST
1187	TP BUSBAR	TP BUSBAR
1188	TP CABLE	TP CABLE
1189	TP INSULATOR	TP INSULATOR
1190	TP WIRE	TP WIRE
1191	TP MOTOR SWITCH	TP MOTOR SWITCH
1192	TP TERMINATION	TP TERMINATION
1193	TP GROUND GRID	TP GROUND GRID
1194	TP GANTRY TRANSFORMER	TP GANTRY TRANSFORMER
1195	TP CLAMP	TP CLAMP
1196	TP CONCRETE	TP CONCRETE
1197	TP GRADE	TP GRADE
1198	TP Undefined	Open
1199	TP Undefined	Open
1200	OC Undefined	Open
1201	OC Control	(Includes Survey Monuments)
1202	OC Dropout	Open
1203	OC Dropout	Open
1204	OC Dropout	Open
1205	OC Dropout	Open
1206	OC Dropout	Open
1207	OC Dropout	Open
1208	OC Dropout	Open
1209	OC Dropout	Open
1210	OC Sheet Format	(Includes North Arrow)
1211	OC Line works	All line work
1212	OC Dimension	Dimension Line



1213	OC Centerline	Center Line
1214	OC Hiddenline	Hidden Line
1215	OC Matchline	Match Line
1216	OC Misc Line	Misc. line
1217	OC Undefined	Undefined level
1218	OC Undefined	Undefined level
1219	OC Revision Cloud	Revision Cloud line
1220	OC Undefined	Open
1221	OC Standard Text	Standard and Notes Text
1222	OC Detail Title Text	Detail and Section Title Text
1223	OC Matchline Text	Match Line Text
1224	OC Border Text	Text for the Border
1225	OC Revision Text	Text for the revision block
1226	OC Undefined	Undefined level
1227	OC Undefined	Undefined level
1228	OC Undefined	Undefined level
1229	OC Undefined	Undefined level
1230	OC Undefined	Undefined level
1231	OC Undefined	Undefined level
1232	OC Undefined	Undefined level
1233	OC Undefined	Undefined level
1234	OC Undefined	Undefined level
1235	OC Undefined	Undefined level
1236	OC Undefined	Undefined level
1237	OC Undefined	Undefined level
1238	OC Undefined	Undefined level
1239	OC Undefined	Undefined level
1240	OC Undefined	Undefined level
1241	OC Undefined	Undefined level
1242	OC Undefined	Undefined level
1243	OC Undefined	Undefined level
1244	OC Undefined	Undefined level
1245	OC Undefined	Undefined level
1246	OC Undefined	Undefined level
1247	OC Undefined	Undefined level
1248	OC Undefined	Undefined level
1249	OC Undefined	Undefined level
1250	OC Undefined	Undefined level
1251	OC Undefined	Undefined level
1252	OC Undefined	Undefined level
1253	OC Undefined	Undefined level
1254	OC Undefined	Undefined level



1255	OC Undefined	Undefined level
1256	OC Undefined	Undefined level
1257	OC Undefined	Undefined level
1258	OC Undefined	Undefined level
1259	OC Undefined	Undefined level
1260	OC Undefined	Undefined level
1261	OC Undefined	Undefined level
1262	OC Undefined	Undefined level
1263	OC Undefined	Undefined level
1264	OC Undefined	Undefined level
1265	OC Undefined	Undefined level
1266	OC Undefined	Undefined level
1267	OC Undefined	Undefined level
1268	OC Undefined	Undefined level
1269	OC Undefined	Undefined level
1270	OC Undefined	Undefined level
1271	OC Undefined	Undefined level
1272	OC Undefined	Undefined level
1273	OC Undefined	Undefined level
1274	OC Undefined	Undefined level
1275	OC Undefined	Undefined level
1276	OC Undefined	Undefined level
1277	OC Undefined	Undefined level
1278	OC Undefined	Undefined level
1279	OC Undefined	Undefined level
1280	OC Undefined	Undefined level
1281	OC Undefined	Undefined level
1282	OC Undefined	Undefined level
1283	OC Undefined	Undefined level
1284	OC Undefined	Undefined level
1285	OC Undefined	Undefined level
1286	OC Undefined	Undefined level
1287	OC Undefined	Undefined level
1288	OC Undefined	Undefined level
1289	OC Undefined	Undefined level
1290	OC Undefined	Undefined level
1291	OC Undefined	Undefined level
1292	OC Undefined	Undefined level
1293	OC Undefined	Undefined level
1294	OC Undefined	Undefined level
1295	OC Undefined	Undefined level
1296	OC Undefined	Undefined level



1297	OC Undefined	Undefined level
1298	OC Undefined	Undefined level
1299	OC Undefined	Undefined level
1300	TC Undefined	Undefined level
1301	TC Undefined	Undefined level
1302	TC Undefined	Undefined level
1303	TC Undefined	Undefined level
1304	TC Undefined	Undefined level
1305	TC Undefined	Undefined level
1306	TC Undefined	Undefined level
1307	TC Undefined	Undefined level
1308	TC Undefined	Undefined level
1309	TC Undefined	Undefined level
1310	TC Match Line Text	Match Line Text
1311	TC Sig-E qpm	Signal Equipment
1312	TC Sig-E qpm-Conn	Signal Equipment Connection
1313	TC Sig-E qpm-Text	Signal Equipment Text
1314	TC Undefined	Undefined level
1315	TC Undefined	Undefined level
1316	TC Undefined	Undefined level
1317	TC Undefined	Undefined level
1318	TC Undefined	Undefined level
1319	TC Undefined	Undefined level
1320	TC Undefined	Undefined level
1321	TC Undefined	Undefined level
1322	TC Undefined	Undefined level
1323	TC Undefined	Undefined level
1324	TC Undefined	Undefined level
1325	TC Undefined	Undefined level
1326	TC Undefined	Undefined level
1327	TC Undefined	Undefined level
1328	TC Undefined	Undefined level
1329	TC Undefined	Undefined level
1330	TC Undefined	Undefined level
1331	TC Undefined	Undefined level
1332	TC Undefined	Undefined level
1333	TC Undefined	Undefined level
1334	TC Undefined	Undefined level
1335	TC Undefined	Undefined level
1336	TC Undefined	Undefined level
1337	TC Undefined	Undefined level
1338	TC Undefined	Undefined level



1339	TC Undefined	Undefined level
1340	TC Undefined	Undefined level
1341	TC Undefined	Undefined level
1342	TC Undefined	Undefined level
1343	TC Undefined	Undefined level
1344	TC Undefined	Undefined level
1345	TC Undefined	Undefined level
1346	TC Undefined	Undefined level
1347	TC Undefined	Undefined level
1348	TC Undefined	Undefined level
1349	TC Undefined	Undefined level
1350	TC Undefined	Undefined level
1351	TC Undefined	Undefined level
1352	TC Undefined	Undefined level
1353	TC Undefined	Undefined level
1354	TC Undefined	Undefined level
1355	TC Undefined	Undefined level
1356	TC Undefined	Undefined level
1357	TC Undefined	Undefined level
1358	TC Undefined	Undefined level
1359	TC Undefined	Undefined level
1360	TC Undefined	Undefined level
1361	TC Undefined	Undefined level
1362	TC Undefined	Undefined level
1363	TC Undefined	Undefined level
1364	TC Undefined	Undefined level
1365	TC Undefined	Undefined level
1366	TC Undefined	Undefined level
1367	TC Undefined	Undefined level
1368	TC Undefined	Undefined level
1369	TC Undefined	Undefined level
1370	TC Undefined	Undefined level
1371	TC Undefined	Undefined level
1372	TC Undefined	Undefined level
1373	TC Undefined	Undefined level
1374	TC Undefined	Undefined level
1375	TC Undefined	Undefined level
1376	TC Undefined	Undefined level
1377	TC Undefined	Undefined level
1378	TC Undefined	Undefined level
1379	TC Undefined	Undefined level
1380	TC Undefined	Undefined level



1381	TC Undefined	Undefined level
1382	TC Undefined	Undefined level
1383	TC Undefined	Undefined level
1384	TC Undefined	Undefined level
1385	TC Undefined	Undefined level
1386	TC Undefined	Undefined level
1387	TC Undefined	Undefined level
1388	TC Undefined	Undefined level
1389	TC Undefined	Undefined level
1390	TC Undefined	Undefined level
1391	TC Undefined	Undefined level
1392	TC Undefined	Undefined level
1393	TC Undefined	Undefined level
1394	TC Undefined	Undefined level
1395	TC Undefined	Undefined level
1396	TC Undefined	Undefined level
1397	TC Undefined	Undefined level
1398	TC Undefined	Undefined level
1399	TC Undefined	Undefined level
1400	CO Undefined	Undefined level
1401	CO Undefined	Undefined level
1402	CO Undefined	Undefined level
1403	CO Undefined	Undefined level
1404	CO Undefined	Undefined level
1405	CO Undefined	Undefined level
1406	CO Undefined	Undefined level
1407	CO Undefined	Undefined level
1408	CO Undefined	Undefined level
1409	CO Undefined	Undefined level
1410	CO Match Line Txt	Match Line Text
1411	CO Eqpm	Communication Equipment
1412	CO Eqpm-Conn	Communication Equipment Connection
1413	CO Eqpm-Txt	Communication Equipment Text
1414	CO Undefined	Undefined level
1415	CO Undefined	Undefined level
1416	CO Undefined	Undefined level
1417	CO Undefined	Undefined level
1418	CO Undefined	Undefined level
1419	CO Undefined	Undefined level
1420	CO Undefined	Undefined level
1421	CO Undefined	Undefined level
1422	CO Undefined	Undefined level



1423	CO Undefined	Undefined level
1424	CO Undefined	Undefined level
1425	CO Undefined	Undefined level
1426	CO Undefined	Undefined level
1427	CO Undefined	Undefined level
1428	CO Undefined	Undefined level
1429	CO Undefined	Undefined level
1430	CO Undefined	Undefined level
1431	CO Undefined	Undefined level
1432	CO Undefined	Undefined level
1433	CO Undefined	Undefined level
1434	CO Undefined	Undefined level
1435	CO Undefined	Undefined level
1436	CO Undefined	Undefined level
1437	CO Undefined	Undefined level
1438	CO Undefined	Undefined level
1439	CO Undefined	Undefined level
1440	CO Undefined	Undefined level
1441	CO Undefined	Undefined level
1442	CO Undefined	Undefined level
1443	CO Undefined	Undefined level
1444	CO Undefined	Undefined level
1445	CO Undefined	Undefined level
1446	CO Undefined	Undefined level
1447	CO Undefined	Undefined level
1448	CO Undefined	Undefined level
1449	CO Undefined	Undefined level
1450	CO Undefined	Undefined level
1451	CO Undefined	Undefined level
1452	CO Undefined	Undefined level
1453	CO Undefined	Undefined level
1454	CO Undefined	Undefined level
1455	CO Undefined	Undefined level
1456	CO Undefined	Undefined level
1457	CO Undefined	Undefined level
1458	CO Undefined	Undefined level
1459	CO Undefined	Undefined level
1460	CO Undefined	Undefined level
1461	CO Undefined	Undefined level
1462	CO Undefined	Undefined level
1463	CO Undefined	Undefined level
1464	CO Undefined	Undefined level



1465	CO Undefined	Undefined level
1466	CO Undefined	Undefined level
1467	CO Undefined	Undefined level
1468	CO Undefined	Undefined level
1469	CO Undefined	Undefined level
1470	CO Undefined	Undefined level
1471	CO Undefined	Undefined level
1472	CO Undefined	Undefined level
1473	CO Undefined	Undefined level
1474	CO Undefined	Undefined level
1475	CO Undefined	Undefined level
1476	CO Undefined	Undefined level
1477	CO Undefined	Undefined level
1478	CO Undefined	Undefined level
1479	CO Undefined	Undefined level
1480	CO Undefined	Undefined level
1481	CO Undefined	Undefined level
1482	CO Undefined	Undefined level
1483	CO Undefined	Undefined level
1484	CO Undefined	Undefined level
1485	CO Undefined	Undefined level
1486	CO Undefined	Undefined level
1487	CO Undefined	Undefined level
1488	CO Undefined	Undefined level
1489	CO Undefined	Undefined level
1490	CO Undefined	Undefined level
1491	CO Undefined	Undefined level
1492	CO Undefined	Undefined level
1493	CO Undefined	Undefined level
1494	CO Undefined	Undefined level
1495	CO Undefined	Undefined level
1496	CO Undefined	Undefined level
1497	CO Undefined	Undefined level
1498	CO Undefined	Undefined level
1499	CO Undefined	Undefined level
1500	GT Undefined	Undefined level
1501	GT Undefined	Undefined level
1502	GT Undefined	Undefined level
1503	GT Undefined	Undefined level
1504	GT Undefined	Undefined level
1505	GT Undefined	Undefined level
1506	GT Undefined	Undefined level



1507	GT Undefined	Undefined level
1508	GT Undefined	Undefined level
1509	GT Undefined	Undefined level
1510	GT Notes	Geotech General Notes
1511	GT Dimensions	Geotech Dimension
1512	GT Text	Geotech Text
1513	GT Symbols	Geotech Symbols
1514	GT Legend	Geotech Legend
1515	GT Pattern	Geotech Patterning
1516	GT Shape	Geotech Shapes
1517	GT Undefined	Undefined level
1518	GT Undefined	Undefined level
1519	GT Undefined	Undefined level
1520	GT Undefined	Undefined level
1521	GT Existing Boreholes	GT Existing Boreholes
1522	GT CHSR PL Proposed Boreholes	GT CHSR PL Proposed Boreholes
1523	GT CHSR PL Proposed Boreholes	GT CHSR PL Proposed Boreholes
1524	GT CHSR PL Proposed Boreholes	GT CHSR PL Proposed Boreholes
1525	GT CHSR PL Proposed Boreholes	GT CHSR PL Proposed Boreholes
1526	GT Undefined	Undefined level
1527	GT Undefined	Undefined level
1528	GT Undefined	Undefined level
1529	GT Geothermal Fields	GT Geothermal Fields
1530	GT Undefined	Undefined level
1531	GT Groundwater Contours	GT Groundwater Contours
1532	GT Water Wells	GT Water Wells
1533	GT Landslide Points	GT Landslide Points
1534	GT Undefined	Undefined level
1535	GT Undefined	Undefined level
1536	GT Landslides	GT Landslides
1537	GT Dam Inundation Z ones	GT Dam Inundation Z ones
1538	GT Undefined	Undefined level
1539	GT Hot Springs	GT Hot Springs
1540	GT Liquefaction Zones	GT Liquefaction Zones
1541	GT Methane Fields	GT Methane Fields
1542	GT Undefined	Undefined level
1548	GT Undefined	Undefined level
1544	GT Oil and Gas Fields (DOGGER)	GT Oil and Gas Fields (DOGGER)
1545	GT Wells	Operator, type, etc
1549	GT Shearwave Velocity	VS Category
1550	GT Alquist fault Zones	GT Alquist fault Zones
1551	GT Fault Hazard Zones	Zone; Primary



1552	GT Faults	Type
1553	GT Faults	Age ; type
1554	GT Faults	Same as USGS_FAULT
1555	GT Undefined	Undefined level
1556	GT Undefined	Undefined level
1557	GT Undefined	Undefined level
1558	GT Boring Stick Existing	GT Boring Stick Existing
1559	GT Boring Stick Proposed	GT Boring Stick Proposed
1560	GT Undefined	Undefined level
1561	GT Undefined	Undefined level
1562	GT Undefined	Undefined level
1563	GT Undefined	Undefined level
1564	GT Undefined	Undefined level
1565	GT Undefined	Undefined level
1566	GT Undefined	Undefined level
1567	GT Undefined	Undefined level
1568	GT Undefined	Undefined level
1569	GT Undefined	Undefined level
1570	GT Undefined	Undefined level
1571	GT Undefined	Undefined level
1572	GT Undefined	Undefined level
1573	GT Undefined	Undefined level
1574	GT Undefined	Undefined level
1575	GT Undefined	Undefined level
1576	GT Undefined	Undefined level
1577	GT Undefined	Undefined level
1578	GT Undefined	Undefined level
1579	GT Undefined	Undefined level
1580	GT Undefined	Undefined level
1581	GT Undefined	Undefined level
1582	GT Undefined	Undefined level
1583	GT Undefined	Undefined level
1584	GT Undefined	Undefined level
1585	GT Undefined	Undefined level
1586	GT Undefined	Undefined level
1587	GT Undefined	Undefined level
1588	GT Undefined	Undefined level
1589	GT Undefined	Undefined level
1590	GT Undefined	Undefined level
1591	GT Undefined	Undefined level
1592	GT Undefined	Undefined level
1593	GT Undefined	Undefined level



1594	GT Undefined	Undefined level
1595	GT Undefined	Undefined level
1596	GT Undefined	Undefined level
1597	GT Undefined	Undefined level
1598	GT Undefined	Undefined level
1599	GT Undefined	Undefined level
1600	MY Undefined	Undefined level
1601	MY Undefined	Undefined level
1602	MY Undefined	Undefined level
1603	MY Undefined	Undefined level
1604	MY Undefined	Undefined level
1605	MY Undefined	Undefined level
1606	MY Undefined	Undefined level
1607	MY Undefined	Undefined level
1608	MY Undefined	Undefined level
1609	MY Undefined	Undefined level
1610	MY Undefined	Undefined level
1611	MY Undefined	Undefined level
1612	MY Undefined	Undefined level
1613	MY Undefined	Undefined level
1614	MY Undefined	Undefined level
1615	MY Undefined	Undefined level
1616	MY Undefined	Undefined level
1617	MY Undefined	Undefined level
1618	MY Undefined	Undefined level
1619	MY Undefined	Undefined level
1620	MY Undefined	Undefined level
1621	MY Undefined	Undefined level
1622	MY Undefined	Undefined level
1623	MY Undefined	Undefined level
1624	MY Undefined	Undefined level
1625	MY Undefined	Undefined level
1626	MY Undefined	Undefined level
1627	MY Undefined	Undefined level
1628	MY Undefined	Undefined level
1629	MY Undefined	Undefined level
1630	MY Undefined	Undefined level
1631	MY Undefined	Undefined level
1632	MY Undefined	Undefined level
1633	MY Undefined	Undefined level
1634	MY Undefined	Undefined level
1635	MY Undefined	Undefined level





















1636	MY Undefined	Undefined level
1637	MY Undefined	Undefined level
1638	MY Undefined	Undefined level
1639	MY Undefined	Undefined level
1640	MY Undefined	Undefined level
1641	MY Undefined	Undefined level
1642	MY Undefined	Undefined level
1643	MY Undefined	Undefined level
1644	MY Undefined	Undefined level
1645	MY Undefined	Undefined level
1646	MY Undefined	Undefined level
1647	MY Undefined	Undefined level
1648	MY Undefined	Undefined level
1649	MY Undefined	Undefined level
1650	MY Undefined	Undefined level
1651	MY Undefined	Undefined level
1652	MY Undefined	Undefined level
1653	MY Undefined	Undefined level
1654	MY Undefined	Undefined level
1655	MY Undefined	Undefined level
1656	MY Undefined	Undefined level
1657	MY Undefined	Undefined level
1658	MY Undefined	Undefined level
1659	MY Undefined	Undefined level
1660	MY Undefined	Undefined level
1661	MY Undefined	Undefined level
1662	MY Undefined	Undefined level
1663	MY Undefined	Undefined level
1664	MY Undefined	Undefined level
1665	MY Undefined	Undefined level
1666	MY Undefined	Undefined level
1667	MY Undefined	Undefined level
1668	MY Undefined	Undefined level
1669	MY Undefined	Undefined level
1670	MY Undefined	Undefined level
1671	MY Undefined	Undefined level
1672	MY Undefined	Undefined level
1673	MY Undefined	Undefined level
1674	MY Undefined	Undefined level
1675	MY Undefined	Undefined level
1676	MY Undefined	Undefined level
1677	MY Undefined	Undefined level













1678	MY Undefined	Undefined level
1679	MY Undefined	Undefined level
1680	MY Undefined	Undefined level
1681	MY Undefined	Undefined level
1682	MY Undefined	Undefined level
1683	MY Undefined	Undefined level
1684	MY Undefined	Undefined level
1685	MY Undefined	Undefined level
1686	MY Undefined	Undefined level
1687	MY Undefined	Undefined level
1688	MY Undefined	Undefined level
1689	MY Undefined	Undefined level
1690	MY Undefined	Undefined level
1691	MY Undefined	Undefined level
1692	MY Undefined	Undefined level
1693	MY Undefined	Undefined level
1694	MY Undefined	Undefined level
1695	MY Undefined	Undefined level
1696	MY Undefined	Undefined level
1697	MY Undefined	Undefined level
1698	MY Undefined	Undefined level
1699	MY Undefined	Undefined level



APPENDIX G – LIFESTYLE RESOURCE FILE











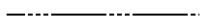







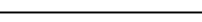

PROJECT PLANS (100S)-DASHED LINES		
NAME	DESCRIPTION	IMAGE
PP-AXIS	SUPER AXIS OF ROTATION	
PP-CITY	CITY OWNER LINE	
PP-CLDET	DETAIL CENTER LINE	
PP-COUNTY	COUNTY OWNER LINE	
PP-DOTO	DOTTED LINE	
PP-FOREST	FOREST BOUNDARY	
PP-LC1	DOTTED LINE	
PP-LC2	MEDIUM DASH	
PP-LC3	LONG DASH	
PP-LC4	DASH-DOT	
PP-LC5	SHORT DASH	
PP-LC6	DASH-DOT-DOT	
PP-LC7	LONG DASH-SHORT DASH	
PP-LDASH	LONG DASH	
PP-MATCH	MATCH LINE	
PP-MDASH	MEDIUM DASH	
PP-SDASH	SHORT DASH	
PP-STATE	STATE BOUNDARY	

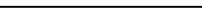
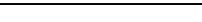
LANDSCAPE (200S)		
NAME	DESCRIPTION	IMAGE
IS-CNC-P	CONTROL AND NEUTRAL CONDUCTOR	
IS-CNC-X	CONTROL AND NEUTRAL CONDUCTOR (EXISTING)	
IS-COND-P	CONDUIT	
IS-COND-X	CONDUIT (EXISTING)	
IS-DIP-P	DUCTILE IRON PIPE	
IS-DIP-X	DUCTILE IRON PIPE (EXISTING)	
IS-GC1	GROUND COVER	
IS-GSP-P	GALV STEEL PIPE	
IS-GSP-X	GALV STEEL PIPE (EXISTING)	
IS-PP-X	PLASTIC PIPE (EXISTING)	

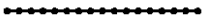

LANDSCAPE (200S)		
NAME	DESCRIPTION	IMAGE
IS-PPIL-P	PLASTIC PIPE IRRIGATION	
IS-PPIL-X	PLASTIC PIPE IRRIGATION (EXISTING)	
IS-S10A	ARC ANGLE SHRUB 3 M WIDE	
IS-S10AF	ARC ANGLE SHRUB 3 M WIDE	
IS-S10B	CLOUD SHRUB 1 SIDE	
IS-S10BF	CLOUD SHRUB 3 M WIDE	
IS-S10C	ROUND SHRUB 3 M CTRS 1SD	
IS-S10CF	ROUND SHRUB 3 M CTRS 2SD	
IS-S15A	SQUARE SHRUB 2 M CTRS 1 SD	
IS-S15AF	SQUARE SHRUB 2 M CTRS 2 SD	
IS-S15B	ROUND SHRUB 4.5 M CTRS 1SD	
IS-S15BF	ROUND SHRUB 4.5 M CTRS 2SD	
IS-S15C	CASTLE SHRUB 1 SIDE	
IS-S15CF	CASTLE SHRUB 3 M WIDE	
IS-S20A	ROUND SHRUB 6 M CTR 1SD	
IS-S20AF	ROUND SHRUB 6 M CTR 2SD	
IS-S20B	CLOUD SHRUB 1 SIDE	
IS-S20BF	CLOUD SHRUB 3 M WIDE	
IS-S6A	ROUND SHRUB 1.5 M CTRS 1SD	
IS-S6AF	ROUND SHRUB 2 M CTRS 2SD	
IS-S6B	SQUARE SHRUB 2 M CTRS 1SD	
IS-S6BF	SQUARE SHRUB 2 M CTRS 2SD	
IS-SCC-P	SPRINKLER CONTROL COND	
IS-SCC-X	SPRINKLER CONTROL COND (EXISTING)	
IS-VINE1	VINE-OPEN	
IS-VINE2	VINE-FULL	
IS-VINE3	VINE-OPEN WITH V	
IS-SLEEVE-P	IRRIGATION SLEEVE	
IS-SLEEVE-X	IRRIGATION SLEEVE (EXISTING)	

ROADWAY (400S)		
NAME	DESCRIPTION	IMAGE
RD-BARRIER	CONCRETE BARRIER	
RD-CMP	CURRUGATED METAL PIPE	
RD-CURB	CURB	
RD-CURBG	CURB AND GUTTER	
RD-DBLBAR	DOUBLE BEAM BARRIER	
RD-FENCE	FENCE	
RD-FLOWLN	DRAINAGE FLOW LINE	
RD-GRIND	GRIND PCC	
RD-MBGR-P	GUARD RAIL	
RD-MBGR-X	GUARD RAIL (EXISTING)	
RD-OG	ORIGINAL GROUND	
RD-PIPEL-P	DRAIN LINE (1-2M)	
RD-PIPEL-X	DRAIN LINE (1-2M) (EXISTING)	
RD-PLANING	PLANING	
RD-PLANRESF	RESURFACE/OBLITERATE	
RD-RESURF	RESURFACE	
RD-WALLBAR	WALL TOP OF BARRIER	
RD-WALL-P	WALL (NEW)	
RD-WALL-X	WALL (EXISTING)	
RD-LNSTRPDSH	LANE STRIPE-DASH	
RD-KRAIL	TEMPORARY K-RAIL	
RD-WATEREDGE	RIVER AND LAKE BOUNDARIES	
RD-STREAM	RIVERS AND CREEKS	
RD-WALLS	WALL ON WALL	
RD-LNSTRPDBL1	LANE STRIPING (SOLID/DASH)	
RD-LNSTRPDBL2	LANE STRIPING (DASH/SOLID)	
RD-LNSTRPDBL3	LANE STRIPING (DBL SOLID)	

RIGHT OF WAY (500S)		
NAME	DESCRIPTION	IMAGE
RW-CLIMIT	CITY LIMIT LINE	
RW-CTRLN	CENTER LINE	
RW-SECTL	SECTION LINE	
RW-SUBDL	SUB DIVISION LINE	
RW-ARRDBL-NAR0	DOUBLE ENDED NARROW ARROW WITH SOLID LINE	
RW-ARRDBL-NAR1	DOUBLE ENDED NARROW ARROW WITH DASHED LINE	
RW-ARRDBL-STD0	DOUBLE ENDED STANDARD ARROW WITH SOLID LINE	
RW-ARRDBL-STD1	DOUBLE ENDED STANDARD ARROW WITH DASHED LINE	
RW-ARR-NAR0	NARROW ARROW WITH SOLID LINE	
RW-ARR-NAR1	NARROW ARROW WITH DASHED LINE	
RW-ARR-STD0	STANDARD ARROW WITH SOLID LINE	
RW-ARR-STD1	STANDARD ARROW WITH DASHED LINE	
RW-ARRSYM-NAR0	NARROW ARROW TO SYMBOL WITH SOLID LINE	
RW-ARRSYM-NAR1	NARROW ARROW TO SYMBOL WITH DASHED LINE	
RW-ARRSYM-STD0	STANDARD ARROW TO SYMBOL WITH SOLID LINE	
RW-ARRSYM-STD1	STANDARD ARROW TO SYMBOL WITH DASHED LINE	
RW-DIMDBL	DOUBLE ENDED DIMENSION LEADER	
RW-DIMSINGLE	DIMENSION LEADER	
RW-COLOREASE	PARCEL EASEMENT COLORING	
RW-COLORREMAIN	PARCEL REMAINDER UNDERLINE	
RW-DETAILUNDER	DETAIL ANNOTATION UNDERLINE	
RW-FREELEASE	FREEWAY LEASE AREA	
RW-SUPPREF	UNASSIGNED REFERENCE AREA	



RIGHT OF WAY (500S)		
NAME	DESCRIPTION	IMAGE
RW-EASEEXIST	EXISTING EASEMENT	-----
RW-EASENEW	NEW EASEMENT	-----
RW-ACCESS-LT	R/W ACCESS PROHIBITED (L)	+++++
RW-ACCSU-LT	R/W ACCESS CONTROL (L)	. +++ +++
RW-ACCREL-LT	RELINQUISHED R/W ACCESS CONTROL (L)	+++++
RW-ACCESS-RT	R/W ACCESS PROHIBITED (R)	+++++
RW-ACCSU-RT	R/W ACCESS CONTROL (R)	. +++ +++
RW-ACCREL-RT	RELINQUISHED R/W ACCESS CONTROL (R)	+++++
RW-SUPERCEDED	SUPERCEDED R/W (CONVENTIONAL)	-----
RW-COMMON	COMMON PROPERTY LINE (SAME OWNER)	-----

UTILITIES (700S)		
NAME	DESCRIPTION	IMAGE
UT-ELEC-P	ELECTRICAL CONDUIT (UG)	--E-----E--
UT-ELEC-X	ELECTRICAL CONDUIT (EXIST)	--e-----e--
UT-GAS-P	GASOLINE CONDUIT	--G-----G--
UT-GAS-X	GASOLINE CONDUIT (EXIST)	--g-----g--
UT-NATGAS-P	NATURAL GAS	-G-----G-
UT-NATGAS-X	NATURAL GAS (EXIST)	-g-----g-
UT-OIL-P	OIL LINE	--O-----O--
UT-OIL-X	OIL LINE (EXIST)	--o-----o--
UT-SEWER-P	SEWER LINE	-S-----S-
UT-SEWER-X	SEWER LINE (EXIST)	-s-----s-
UT-STEAM-P	STEAM UTILITY LINE	--ST-----ST--
UT-STEAM-X	STEAM UTILITY LINE (EXIST)	--st-----st--
UT-STORMD-P	STORM DRAIN LINE	--SD-----SD--
UT-STORMD-X	STORM DRAIN LINE (EXIST)	--sd-----sd--



UTILITIES (700S)		
NAME	DESCRIPTION	IMAGE
UT-TELECOM-P	TELEMETER CABLE LINE	-- TC ————— TC—
UT-TELECOM-X	TELEMETER CABLE LINE (EXIST)	---+-----+---
UT-TELEPH-P	TELEPHONE LINE (UG)	---T-----T---
UT-TELEPH-X	TELEPHONE LINE (EXIST)	---+-----+---
UT-TV-P	TELEVISION LINE (UG)	..TV-----TV..
UT-TV-X	TELEVISION LINE (EXIST)	---+v-----+v---
UT-WATER-P	WATER LINE	— W ————— W—
UT-WATER-X	WATER LINE (EXIST)	— v ————— v—

WATER POLLUTION CONTROL-WPC-BMPS (800S)		
NAME	DESCRIPTION	IMAGE
SW-TFESA	TEMPORARY FENCE	— TFESA —
SW-TSF	TEMPORARY SILT FENCE	— x x x x x x x x —
SW-TFR	TEMPORARY FIBER ROLL	//////////
SW-TGBB	TEMPORARY GRAVEL BAG BARRIER	— T G B B —
SW-TSBB	TEMPORARY STRAW BALE BARRIER	— S B B —
SW-TSDFP	TEMPORARY SLOPE DRAIN FLEX PIPE	▷ ◁
SW-TEB	TEMPORARY EARTH BERM	//////////
SW-TDS	TEMPORARY DITCH/SWALE	— ~ ~ ~ ~ ~ —
SW-TLB1	TEMPORARY LINEAR BARRIER (TYPE 1)	— ■ ■ ■ ■ ■ —
SW-TLB2	TEMPORARY LINEAR BARRIER (TYPE 2)	— ■ ■ ■ ■ ■ —
SW-TLB3	TEMPORARY LINEAR BARRIER (TYPE 3)	— ○ ○ ○ ○ ○ —
SW-FR	FIBER ROLL	////////// FR //////////



APPENDIX H – CALIFORNIA COORDINATE SYSTEM (CCS83)

