

California High-Speed Train Project



TECHNICAL MEMORANDUM

Automatic Train Control Site Requirements TM 3.3.2

Prepared by: Signed document on file 21 Jun 10
Harvey Glickenstein Date

Checked by: Signed document on file 22 Jun 10
Ed Mortlock Date

Approved by: Signed document on file 25 Jun 10
Ken Jong, PE, Engineering Manager Date

Released by: Signed document on file 28 Jun 10
Anthony Daniels, Program Director Date

Revision	Date	Description
0	25 Jun 10	Initial Release

Note: Signatures apply for the latest technical memorandum revision as noted above.



Draft of 3/31

This document has been prepared by **Parsons Brinckerhoff** for the California High-Speed Rail Authority and for application to the California High-Speed Train Project. Any use of this document for purposes other than this Project, or the specific portion of the Project stated in the document, shall be at the sole risk of the user, and without liability to PB for any losses or injuries arising for such use.

System Level Technical and Integration Reviews

The purpose of the review is to ensure:

- Technical consistency and appropriateness
- Check for integration issues and conflicts

System level reviews are required for all technical memoranda. Technical Leads for each subsystem are responsible for completing the reviews in a timely manner and identifying appropriate senior staff to perform the review. Exemption to the system level technical and integration review by any subsystem must be approved by the Engineering Manager.

System Level Technical Reviews by Subsystem:

Systems:	<u>Signed document on file</u> Richard Schmedes	<u>14 Jun 10</u> Date
Infrastructure:	<u>Signed document on file</u> John Chirco	<u>15 Jun 10</u> Date
Operations:	<u>Signed document on file</u> Paul Mosier	<u>25 Jun 10</u> Date
Maintenance:	<u>Signed document on file</u> Paul Mosier	<u>25 Jun 10</u> Date
Rolling Stock:	<u>Signed document on file</u> Terry Brunner	<u>18 Jun 10</u> Date

Note: Signatures apply for the technical memorandum revision corresponding to revision number in header and as noted on cover.

TABLE OF CONTENTS

ABSTRACT	1
1.0 INTRODUCTION	2
1.1 PURPOSE OF TECHNICAL MEMORANDUM	2
1.1.1 HOUSES AT INTERLOCKING LOCATIONS	2
1.1.2 HOUSINGS REQUIRED BETWEEN INTERLOCKINGS	3
1.1.3 LOCATIONS AND FOOTPRINT OF WAYSIDE SIGNALS AT INTERLOCKINGS	3
1.1.4 LOCATIONS AND FOOTPRINTS OF RADIO TOWERS AND ANTENNA SUPPORTS REQUIRED FOR RADIO COMMUNICATIONS FOR TRAIN CONTROL PURPOSES	3
1.2 GENERAL INFORMATION	3
1.2.1 DEFINITION OF TERMS	3
1.2.2 UNITS	4
2.0 DEFINITION OF TECHNICAL TOPIC	5
2.1 GENERAL	5
2.1.1 DESIGN CONSIDERATIONS FOR HOUSES AT INTERLOCKINGS	5
2.1.2 CHSTP DESIGN CONSIDERATIONS FOR USE OF WAYSIDE SIGNALS	5
2.1.3 CHSTP DESIGN CONSIDERATIONS FOR REQUIRED FOOTPRINT FOR SIGNAL HOUSINGS AND WAYSIDE SIGNALS	6
2.1.4 CHSTP ROADWAY AND STAIRWAY ACCESS TO WAYSIDE SIGNAL FACILITIES	6
2.2 LAWS AND CODES	6
3.0 ASSESSMENT / ANALYSIS	8
3.1 GENERAL	8
3.2 HOUSES AT INTERLOCKINGS	8
3.3 WAYSIDE SIGNALS	8
3.4 TRACK CIRCUIT BOUNDARY LOCATIONS	9
3.5 SIGNALING WITHIN YARDS	9
3.6 ATC EQUIPMENT AT STATIONS	9
3.7 CHSTP ACCESS TO WAYSIDE SIGNAL FACILITIES	9
3.8 REGULATORY REQUIREMENTS	10
4.0 SUMMARY AND RECOMMENDATIONS	11
4.1 GENERAL	11
4.2 HOUSINGS AT INTERLOCKINGS	11

4.3 WAYSIDE SIGNALS 11

4.4 YARDS 11

5.0 SOURCE INFORMATION AND REFERENCES 12

6.0 DESIGN MANUAL CRITERIA 13

6.1 GENERAL 13

6.2 HOUSES AT INTERLOCKINGS 13

6.3 WAYSIDE SIGNALS 13

6.4 TRACK CIRCUIT BOUNDARY LOCATIONS 14

6.5 SIGNALING WITHIN YARDS 14

6.6 ATC EQUIPMENT AT STATIONS 14

6.7 CHSTP ACCESS TO WAYSIDE SIGNAL FACILITIES 15

ABSTRACT

The California High Speed Train (CHST) Line requires the deployment of an Automatic Train Control (ATC) system that incorporates the functions of a Positive Train Control (PTC) System as described in TM 3.3.1. Portions of this system will be located along the right-of-way with equipment that must be installed in case enclosures and larger housings that can be located in or adjacent to stations and also near switches and at other wayside locations including track circuit boundaries. The system will also include wayside signals at strategic locations; the need for such wayside signals has yet to be determined however the ability to locate signals if required needs to be protected for in the site requirements.

The purpose of this technical memorandum is to identify and allow for land area for train control system needs such that it can be protected in the right of way footprint, specifically to:

- Identify the types of enclosures and housings that will be needed along the right-of-way and the footprint required for each.
- Identify the wayside signal system equipment including actual signals that may be needed along the right-of-way and the footprint required for each type of signal.
- Identify the footprint needs for the communications infrastructure required to support the ATC system including communications equipment housings and antenna tower requirements and coordinate with the communications systems group.
- Identify the access required to each housing, signal, and antenna site along the right-of-way.

1.0 INTRODUCTION

There are four basic issues covered in this Technical Memorandum (TM):

1. Locations and footprint requirements of Automatic Train Control (ATC) enclosures and housings along the right-of-way.
2. Locations and footprint requirements of ATC wayside signals along the right-of-way.
3. Locations and footprint requirements of antenna towers for radio communications for ATC purposes.
4. Roadway and pedestrian access required to ATC system enclosures and housings and facilities, wayside signals, and communications equipment, including radio antenna towers, required to support the ATC system along the right-of-way. Locations of, and access to, radio antennas to support services other than train control are not included in this Technical Memorandum.

1.1 PURPOSE OF TECHNICAL MEMORANDUM

The purpose of this Technical Memorandum is to provide footprint information for the elements of the ATC system that will be deployed along the right-of-way.

Where High Speed Trains share tracks or a corridor with other railroads, footprint requirements for other railroads' equipment are not addressed in this TM.

Where space can be found within train control enclosures for communications equipment that will eliminate a need for a separate housing, allowance for this equipment will be made.

The following technical issues will be addressed in this memorandum:

1.1.1 Houses at Interlocking Locations

Interlocking houses are required to accommodate the interlocking logic electronics together with control equipment for the operation of switches, moveable frogs, and derails; for the detection of switch positions; for control of signal lighting; and for the detection of track circuit occupation in the interlocking region. Logic will also be provided in these houses for the electronic equipment that generates cab signal commands (if track circuit based train control is deployed, or movement authorities that are transmitted wirelessly to trains if ERTMS or similar technology is selected. In the case of ERTMS type systems, this equipment will be the equivalent of the Radio Block Center).

In addition to the main house for interlockings, additional houses are required for secondary equipment including controls, lighting circuits, and batteries due to the extended distances between the interlocking limits. These smaller houses are required adjacent to the switches themselves and the signals. The longer station interlockings with higher speed turnouts are more likely to require larger and/or additional houses than the universal crossover interlockings between stations.

At all interlockings there is likely to be a requirement to install equipment cases adjacent to the track equipment as well as provide for the larger houses. It is assumed that no specific space requirements will be needed for cases; these can be located in line with the OCS poles (see the following section).

1.1.2 Housings required between interlockings

Between interlockings the train control system locations are required to house track circuit equipment. No wayside signals will be provided between the wayside signals at the entrances to the interlockings. These housings will be relatively small and the equipment is assumed to be installed within cases that can be located in line with the OCS support poles and will not exceed the horizontal clearance required for the poles.

1.1.3 Locations and footprint of wayside signals at interlockings

The requirement for wayside signals and their type has yet to be finalized with Operations and the regulatory bodies. Although not required for normal operations (trains will be operated in accordance with Movement Authorities displayed in the cab); signals are likely to be required for abnormal operations during equipment failure and during other emergencies. There are basically two variations of signals that may be specified, high signals require a high pole or bridge that spans the tracks near to switches which require a foundation. The alternative is to specify low signals (also known as dwarfs) which are much smaller, do not require a pole, and have much smaller foundation requirements.

1.1.4 Locations and footprints of radio towers and antenna supports required for radio communications for train control purposes

Radio towers and antennas are required for voice and data communication between the wayside and trains. The train control specification is being written for functional and performance requirements and will not mandate a system that is based on wireless data communications with trains. It is assumed however that for the purposes of this memorandum that radio towers and antennas will be required at train control locations as described so that the footprint areas are allowed for in the station and interlocking land requirements.

In any event, even if a wireless based train control system is not implemented, the tower sites can be used for voice communications and for non-train control data exchange between the wayside and trains.

The assumptions are that radio tower and antenna footprints will be located at interlocking sites and are to be shown in the directive drawings. Radio towers and antennas at intermediate sites, for repeaters are assumed to be able to be mounted adjacent to ballasted track or on structure within the fence lines or parapets and clear of the walkways and the OCS poles and wiring.

1.2 GENERAL INFORMATION

1.2.1 Definition of Terms

The terms listed below are train control relative definitions and acronyms. A complete glossary of design terms, abbreviations and acronyms used by the Project are contained in Technical Memorandum TM 0.0.a; Design Terms, Abbreviations, and Acronyms.

<u>Aspect</u>	The appearance of a wayside signal as viewed from an approaching train. On the CHSTP the appearance will consist of steady or flashing colored lights.
---------------	--

<u>Dwarf Signal</u>	A low wayside signal with minimal preview as opposed to a high signal that is used to provide adequate preview of the aspect displayed to high speed trains.
<u>Footprint</u>	Area of the ground surface covered by a facility, or affected by construction activities. The footprint includes the area surrounding the facility required for the use of the facility, such as room for doors to open and clearance from the facility to the tracks, intrusion fencing, or other facilities.
<u>High Signal</u>	A signal located such that its aspect can be detected by high speed trains sufficiently in advance of the time the train passes the signal that the train engineer can identify the aspect and take proper action by the time the train reaches the signal.
<u>Transition Track</u>	A track used at the entrance to a yard for trains to transition between ATC and Yard modes between the Main Lines and Yard tracks.

Acronyms

ATC	Automatic Train Control
ATO	Automatic Train Operation
CHSTP	California High Speed Train Project
ERTMS	European Railway Traffic Management System
HSR	High-Speed Rail
OCS	Overhead Contact System
PTC	Positive Train Control
SCADA	Supervisory Control and Data Acquisition
TCC	Train Control and Communications
UPS	Uninterruptible Power Supply
WPC	Wayside Power Control Cubicles

1.2.2 Units

The California High-Speed Train Project (CHSTP) is based on U.S. Customary Units consistent with guidelines prepared by the California Department of Transportation (Caltrans) and defined by the National Institute of Standards and Technology (NIST). U.S. Customary Units are officially used in the U.S. and are also known in the U.S. as “English” or “Imperial” units. In order to avoid any confusion, all formal references to units of measure should be made in terms of U.S. Customary Units.

2.0 DEFINITION OF TECHNICAL TOPIC

The following sections contain the information required to identify the typical locations of and sizes of ATC houses, and the footprints required for wayside signals, interlocking equipment, radio communications antenna towers and other wayside signal equipment required for the ATC system, and access requirements (including roadways, gates, and staircases and ladders) for each type of installation.

The recommendations arising out of the requirements identification and the needs analysis are described in Section 4 and in the Directive Drawings referenced also in Section 4.

2.1 GENERAL

The considerations provide for the requirements of each section at the preliminary level of design. They provide for interfaces with different disciplines and preliminary direction to the Final Designer. The Final Designer will modify these as needed and provide for the final interfaces with the other disciplines.

2.1.1 Design Considerations for Houses at Interlockings

There are two basic configurations for houses at interlockings. The control logic and power supply (including Uninterruptible Power Supply (UPS)) for the switch machines, track circuits, and the wayside signals may be located in houses adjacent to the track within the limits of the interlocking. Alternatively, this equipment may be located within an equipment room at a station where the interlocking spans the station. Where an interlocking is not spanning a station, the interlocking logic, control equipment, and UPS must be located in a house along the wayside that is situated within the limits of the interlocking. A sub-option of these two alternatives is to divide the equipment between a main room within a station or house within the interlocking limits plus smaller houses and/or cubicles and cases distributed throughout the interlocking adjacent to the wayside equipment (signals and switch machines). The issues involved, the tradeoffs, and the recommendations as a result of these are further addressed below in Section 3 and 4.

In addition to Train Control equipment in these houses, there will be a need to house communications equipment that supports the train control operation. This equipment includes fiber optic drop and network switch equipment as well as radios for data transmission. Where communications equipment is included within the same house as signal equipment, the battery bank will be sized as a common UPS for both signal and communications equipment.

Where data radio communications is required between the interlocking equipment and trains in the vicinity and with the central control facility, antennas will need to be mounted on monopoles or towers adjacent to the right of way. The towers and masts will require their own footprint with allowances for maintenance access which will include the ability to tilt and/or lower the mast such that the antenna is reachable from the ground. Allowances for towers will be made adjacent to at least one ATC house at each interlocking.

2.1.2 CHSTP Design Considerations for Use of Wayside Signals

At a maximum operating speed of 220 mph, locomotive engineers will have minimal time to see, absorb, and take action on the information displayed on wayside signals. A 30-second preview of a signal at that speed would require the Locomotive Engineer to first detect the signal aspect being displayed 11,000 feet, or more than two miles, before reaching the signal. Normal operations will be under a system where speed limits are displayed in the cab and automatic enforcement taken in the event that the Locomotive

Engineer does not respond appropriately. It is also intended that Automatic Train Operation (ATO) will actually manage the throttle and brake actuations during normal operation at those speeds where the ATC on-board unit will enforce the safe movement of the train between stations and “signal” stops. Wayside signals will only need to be observed at interlockings during service interruptions and failures of the ATC system. Such operations will entail manual operations under specific procedures and at a reduced speed.

2.1.3 CHSTP Design Considerations for Required Footprint for Signal Housings and Wayside Signals

The footprint for the wayside signals will depend on the decision to include them and the type of signal that is selected. If the signals are set high then either ground masts, signal cantilevers, or signal bridges will be required. If dwarf signals are selected, then the footprint required and the foundations required will be substantially reduced. At interlockings cantilevers or bridges will be needed where there are more than two tracks entering the interlocking if it is decided to use high signals.

The Regional Consultants will need to provide sufficient area for the high signals which is the worst case as signal type may not be finalized until detailed design is being performed by the installation contractor.

As discussed in Design Considerations for Houses at Interlockings, above, there are several possibilities for the houses at the interlockings. The final decision as to which arrangement of housings will be chosen at interlockings will be made during the final design. For this reason, the footprint required for the houses at interlockings will be as shown in this Technical Memorandum based on the largest footprint that will be required.

Housings required at track circuit boundaries will be in the form of wayside cases and accommodated in line with the footprint provided for the OCS structures.

2.1.4 CHSTP Roadway and Stairway Access to Wayside Signal Facilities

Roadway access will be required to all major ATC facilities; that is all ATC equipment houses larger than wayside cases that are mounted in line with the OCS poles (see Section 1.1.2). Road level access will not be required to the right-of-way itself if the right of way is elevated or in a cut or tunnel, only to the house, or compound in which the house is located. On an elevated structure or in a cut, a stairway shall be provided from the roadway parking spot to the right-of-way within 250 feet of the location of the house, case, or cubicle. Maintainers will access the interlocking and other locations and housings from the stairway by walking along the right-of-way. It is expected that the maintainer will need to carry hand tools, test equipment, a laptop computer, and hand-portable spare parts from the maintenance truck to the signal facility. This includes all houses, cases, and cubicles at the interlockings, wayside signals, and the ends of each track circuit.

Larger signal equipment items that cannot be hand carried including batteries, impedance bonds, switch machines, and complete signal heads will be replaced outside of revenue hours using rail-mounted vehicles including cranes operating on the tracks originating from the maintenance of way facilities.

2.2 LAWS AND CODES

Initial high-speed train (HST) design criteria will be issued in technical memoranda that provide guidance and procedures to advance the preliminary engineering. When completed, a Design Manual will present design standards and criteria specifically for the design, construction and operation of the CHSTP's high-speed railway.

Criteria for design elements not specific to HST operations will be governed by existing applicable standards, laws and codes. Applicable local building, planning and zoning codes and laws are to be reviewed for the stations, particularly those located within multiple municipal jurisdictions, state rights-of-way, and/or unincorporated jurisdictions.

In the case of differing values, the standard followed shall be that which results in the satisfaction of all applicable requirements. In the case of conflicts, documentation for the conflicting standard is to be prepared and approval is to be secured as required by the affected agency for which an exception is required, whether it be an exception to the CHSTP standards or another agency standards.

3.0 ASSESSMENT / ANALYSIS

3.1 GENERAL

The determination of the locations of signal apparatus and the detail design will be undertaken by the design/build contractor for the train control system and the communications systems. For this reason the site requirements detailed below are based on the largest (worst case) footprint required for those locations. Detailed design, including alternative use of the footprint areas identified will be determined by the Final Designer. Design variance requests need to be made in accordance with TM 1.1.18 where the requirements herein cannot be met.

3.2 HOUSES AT INTERLOCKINGS

The location of houses and the footprint required is shown on Drawing TM 3.3.2 – A and Drawing TM 2.1.3-INTERLOCK_A for stations and interlockings associated with them and on Drawing TM 3.3.2 - B and Drawing TM 2.1.3-INTERLOCK_B for interlockings not associated with stations. The house sizes are based on a configuration of a central house for each interlocking and outlying houses to provide for the electrical feeds to light the signals.

Drawing TM 3.3.2 – A depicts a station interlocking without the universal set of crossovers at the right hand side of the station. If the crossovers are located near the station (within 3,000 feet of the nearest station interlocking limit) the house arrangements as shown at the left hand side of the station should be mirrored at the right hand side. If the universal crossovers are located further than 3,000 feet, then houses shall be provided for these crossovers as per Drawing TM 3.3.2 – B.

Sizing of houses assumes that a communications cabinet will be included in each house for fiber, network switching, and radio functions. The battery bank will be sized in each house so as to be common for the train control and communications equipment.

Each interlocking will need an antenna and mast to provide for the wayside to train radio for train control purposes. A mast height of 100 feet is being assumed. At least one mast installation is being assumed per interlocking.

Each location will require roadway access, although the access would not necessarily have to be at the same grade as the railroad. Maintenance personnel can walk from the nearest station for interlockings associated with stations. Major maintenance, such as replacement of signal heads or track switch machines will be handled by rail-mounted cranes. Other maintenance will be handled using hand-carried tools or test gear that can be carried up or down staircases providing access to the right of way.

3.3 WAYSIDE SIGNALS

Since visibility of signals from high speed trains will be limited, low-level signals will be used for all signals in the high speed territory. In normal operations locomotive engineers will be following train control commands and information from cab displays and observation of the wayside signal is not essential. During failure modes, locomotive engineers may be operating without cab displays and must follow the wayside signal aspects. A typical low level signal is shown in Drawing TM 3.3.2-C.

In the territory where regional trains may share tracks with high speed trains ground mast and signal bridge mounted signals will be required primarily for the use of the non CHSTP trains. Train speeds in these shared track areas will not exceed 125 mph. Drawing TM 3.3.2 - D shows a typical high signal that could be used in this territory.

Drawing TM 3.3.2 – E shows a typical signal bridge over four tracks, the foundations for the bridge are depicted in Drawing TM 3.3.2 – F.

3.4 TRACK CIRCUIT BOUNDARY LOCATIONS

The exact locations of track circuit boundaries will be determined by the design/build contractor for the ATC system.

Housings at these locations will consist of cases located in line with the OCS poles. They will fit within the normal envelope of the right-of-way without the need for additional land. Access to these locations will be as described in Section 3.7 below.

3.5 SIGNALING WITHIN YARDS

At a Yard location there will be a transition track used by trains entering and leaving the yard. Trains entering the yard will do so under full ATC control and then proceed further into yard limits manually. Trains leaving the yard will receive authority to enter the Transition Track from the yard limits manually and then enter the main line under full ATC mode of operation.

Within the yard there will be power-operated switches controlled from a Yard Control Office. Track circuit protection will be provided to prevent operation of yard power switches under a train and also on the Transition Track. Power-operated derails will also be provided to provide blue-flag protection for workmen operating under the trainsets.

Control of track circuits will be from cases along the tracks similar to the ones for track circuit boundaries along the main line.

Wayside signals will be provided to provide authority to the trains to proceed over the power-operated yard switches. These signals will be similar to the signals shown on Drawing TM 3.3.2-C.

Enclosures shall be provided as per Drawing TM 3.3.2 – B where Transition Tracks connect to the main lines.

Enclosures for equipment needed to control the yard signals, power-operated yard switches, and power-operated derails will be similar in size to those shown on Drawing TM 3.3.2-B. Houses, together with wayside cases will be distributed around the Yard as needed.

Equipment required for the Yard Control tower to operate the signal system and supervise train movements around the Yard will be located within the Yard Tower control room and in an equipment room which will be shared with communications equipment. Size requirements for the Yard Tower control room are detailed in TM 3.4.2; Communications Systems Site Requirements.

3.6 ATC EQUIPMENT AT STATIONS

The majority of ATC equipment in and around stations is described in Section 3.2 above. Space provisions will be made in an equipment room at a station for ATC subsystem equipment collocated with communications subsystem equipment. Space requirements for ATC equipment at station room locations are described in TM 3.4.2; Communications Systems Site Requirements.

3.7 CHSTP ACCESS TO WAYSIDE SIGNAL FACILITIES

Roadway access will be required to all signal facilities, although road level access will not be required to the right-of-way itself if the right of way is elevated or in a cut or tunnel. If on elevated or cut, a stairway shall be provided from the roadway parking spot to the right-of-way within 250 feet of the location of the house, case, or cubicle.

Maintainers will access the interlocking and other locations and housings by walking along the right-of-way. It is expected that the maintainer will need to carry hand tools, test equipment, a laptop computer, and hand portable spare parts from the maintenance truck to the signal facility. This includes all housings, cases, and cubicles at the interlockings, wayside signals, and the ends of each track circuit.

For track circuit boundary cases that may be located with as little as one mile separation from the nearest interlocking, no specific pedestrian access is required including gates and staircases to elevated, trench, and tunnel structures. Access to this equipment will either be made by pedestrian maintainers using accesses for other purposes including emergency evacuation, or by rail maintenance vehicle access operating from maintenance bases during the off hours as described below for heavy equipment replacement.

Larger signal equipment items that cannot be hand carried including batteries, impedance bonds, switch machines, and complete signal heads will be replaced using rail-mounted vehicles including cranes operating on the tracks from maintenance bases outside of revenue hours.

3.8 REGULATORY REQUIREMENTS

Existing and anticipated regulatory requirements include regular checks of batteries, undesired grounds, and track switches. These checks can be made using hand-held test equipment. In addition, lenses of wayside signals will need to be cleaned regularly to maintain proper visibility. With the increasing occurrence of remote monitoring of train control apparatus thereby reducing the overall number of times that maintenance forces will need to gain access to ATC housings, it is not anticipated that any new regulatory requirements will require additional access other than that described in this document.

4.0 SUMMARY AND RECOMMENDATIONS

4.1 GENERAL

Typical site requirements for signal housings and apparatus are shown on Drawings TM 3.3.2-A, TM 3.3.2-B, TM 2.1.3-INTERLOCK_A, and TM 2.1.3-INTERLOCK_B. More detailed elements of signals, bridges and foundations are shown on Drawings TM 3.3.2 – D, TM 3.3.2 – E, and TM 3.3.2 – F. The Regional Manager shall coordinate with the Final Train Control Designer to identify the actual property available for installation of the housings and apparatus identified on these plans at each location.

4.2 HOUSINGS AT INTERLOCKINGS

The final designer will make the decision as to the layout of the interlocking within the footprint provided by the Regional Team.

4.3 WAYSIDE SIGNALS

Allowance for signal locations, bridges, and foundations will be made by the regional designers when determining the overall size of the interlocking site.

4.4 YARDS

The final designer for the region will locate all of the signals, power operated switches, power-operated derails, track circuits, and their associated housings within the yards.

5.0 SOURCE INFORMATION AND REFERENCES

49CFR236 FRA Rules, Standards, and Instruction Governing the Installation, Inspection, Maintenance, and Repair of Signal and Train Control Systems, Devices and Appliances

European Technical Specifications for Interoperability (TSIs).

TM 1.1.10; Structure Gauge

TM 1.1.18; Design Variance Guidelines

TM 2.8.2; Access Control and Intrusion protection for High Speed Rail Right of Way and Facilities

Caltrain standard plans for wayside signals and signal structures

AREMA Communications and Signal Manual of Recommended Practice

6.0 DESIGN MANUAL CRITERIA

6.1 GENERAL

The determination of the locations of signal apparatus and the detail design will be provided by the design/build contractor for the train control and communications systems. For this reason the site requirements shown below are based on the largest footprint required for those locations where alternate arrangements will be determined by Final Designer.

6.2 HOUSES AT INTERLOCKINGS

The location of ATC houses and the footprint required is shown on Drawings TM 3.3.2 – A and TM 2.1.3-INTERLOCK_A for stations and interlockings associated with them and on Drawings TM 3.3.2-B and TM 2.1.3-INTERLOCK_B for interlockings not associated with stations. . The house sizes are based on a configuration of a central house for each interlocking and outlying houses to provide for the electrical feeds to light the signals.

Sizing of these houses assumes that a communications cabinet shall be included in each house for fiber, network switching, and radio functions. The battery bank will be sized in each house so as to be common for the train control and communications equipment contained within the same house.

Each interlocking shall require an antenna and mast to provide for the wayside to train radio for ATC system purposes. A mast height of 100 feet shall be assumed. At least one mast installation per interlocking shall be provided for. It shall also be assumed that the mast will be a tilting monopole and allowances shall be made to enable the mast to be tilted to the horizontal to allow maintenance access to the antennas mounted at or near the top of the mast.

Each location shall require roadway access, although the access need not necessarily be at the same grade as the railroad. Maintenance personnel can walk from the nearest station for interlockings associated with stations. Major maintenance and the handling of heavy ATC equipment, such as the replacement of signal heads or track switch machines; will be managed by rail-mounted cranes or grab equipment. Other maintenance will be handled using hand-carried tools or test gear that can be carried up or down staircases providing access to the right of way.

6.3 WAYSIDE SIGNALS

Since visibility of signals from high speed trains will be limited, dwarf signals will be used for all signals in the high speed territory. In normal operations locomotive engineers will be following train control commands and information from cab displays and observation of the wayside signal is not essential. During failure modes, locomotive engineers may be operating without cab displays and must follow the wayside signal aspects.

In the 125 mph (shared track) territories ground mast and signal bridge mounted signals shall be provided for on all tracks.

Drawing TM 3.3.2-C shows a dwarf signal location. Drawings TM 3.3.2-D, TM 3.3.2 – E, and TM 3.3.2 – F show the use of high signals (on single masts and on signal bridges that will span multiple tracks, and foundation requirements) that may be needed at locations in the 125 mph territory where non-high speed trains (regional passenger and temporally separated freight) may share tracks with high speed trains.

6.4 TRACK CIRCUIT BOUNDARY LOCATIONS

The exact locations of track circuit boundaries shall be determined by the design/build contractor for the ATC system.

Housings at these locations will consist of wayside cases located in line with the OCS poles. These cases shall fit within the normal envelope of the right-of-way without the need for additional land. Access to these locations shall be as described in Section 6.7 below.

6.5 SIGNALING WITHIN YARDS

At a Yard location there shall be a transition track used by trains entering and leaving the yard. Trains entering the yard will do so under full ATC control and then proceed further into yard limits manually. Trains leaving the yard will receive authority to enter the Transition Track from the yard limits manually and then enter the main line under full ATC mode of operation.

Within the yard there shall be power-operated switches controlled from a Yard Control Office. Track circuit protection will be provided to prevent operation of yard power switches under a train and also on the Transition Track. Power-operated derails will also be provided to provide blue-flag protection for workmen operating under the trainsets.

Control of track circuits will be from cases along the tracks similar to the ones for track circuit boundaries along the main line.

Wayside signals shall be provided to provide authority to the trains to proceed over the power-operated yard switches. These signals will be similar to the signals shown on Drawing TM 3.3.2-C.

Enclosures shall be provided as per Drawing TM 3.3.2 – B where Transition Tracks connect to the main lines.

Enclosures for equipment needed to control the yard signals, power-operated yard switches, and power-operated derails shall be similar in size to those shown on Drawing TM 3.3.2-B. Houses, together with wayside cases will be distributed around the Yard as needed.

Equipment required for the Yard Control tower to operate the signal system and supervise train movements around the Yard shall be located within the Yard Tower control room and in an equipment room which shall be shared with communications equipment. Size requirements for the Yard Tower control room are detailed in TM 3.4.2; Communications Systems Site Requirements.

The Regional Team shall ensure that sufficient space is allowed to locate all of the required ATC equipment at the proper locations at the transition tracks, within the yards and within the Yard Control tower and its associated equipment room(s).

6.6 ATC EQUIPMENT AT STATIONS

The majority of ATC equipment in and around stations is described in Section 6.2 above. The Regional Team shall ensure that sufficient space is provided to locate all of the required ATC equipment in a room at a station for ATC subsystem equipment collocated with communications subsystem equipment. Space requirements for ATC equipment at station room locations is described in TM 3.4.2; Communications Systems Site Requirements.

6.7 CHSTP ACCESS TO WAYSIDE SIGNAL FACILITIES

Roadway access shall be required to all signal facilities, although road level access will not be required to the right-of-way itself if the right of way is elevated or in a cut or tunnel. If on elevated or cut, a stairway shall be provided from the roadway parking spot to the right-of-way within 250 feet of the location of the housings (houses and cases) or case. Maintainers will access the interlocking and other locations and housings by walking along the right-of-way. It is expected that the maintainer will need to carry hand tools, test equipment, a laptop computer, and hand portable spare parts from the maintenance truck to the signal facility. This includes all housings at the interlockings, wayside signals, and the ends of each track circuit.

For track circuit boundary cases that may be located as close as one mile apart and from the nearest interlocking, no specific pedestrian access is required including gates and staircases to elevated, trench, and tunnel structures. Access to this equipment will either be made by maintainers on foot using accesses that are primarily provided for other purposes (for example emergency evacuation), or by rail mounted maintenance vehicle access operating from maintenance of way facilities outside of revenue hours.

Larger signal equipment items that cannot be hand carried including batteries, impedance bonds, switch machines, and complete signal heads will be delivered to site using rail-mounted vehicles including cranes and grab equipment operating on the tracks from maintenance of way facilities outside of revenue hours.

6/23/2010 2:01:35 PM T:\13259B Calif High Speed Rail\CADD\Directive Drawings\3.3.2\Working\3.3.2-A.dgn

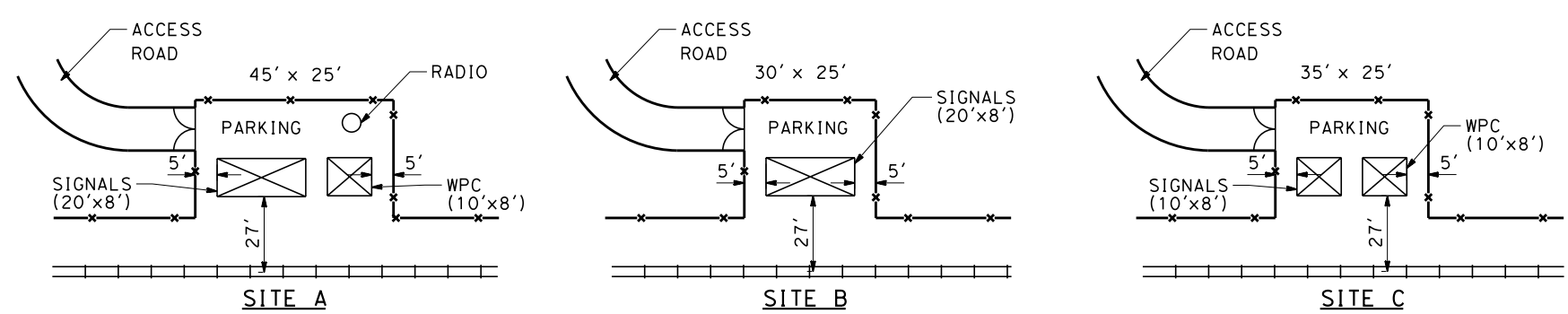
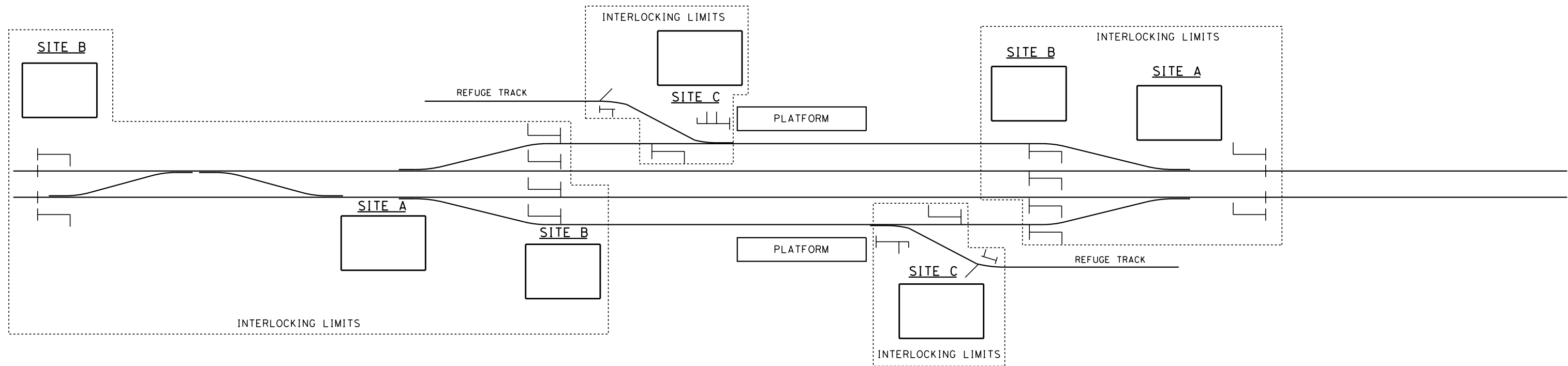

NOTES:

- HOUSINGS MAY BE LOCATED ON EITHER SIDE OF THE TRACK BY DESIGNER PREFERENCE EXCEPT FOR HOUSINGS ADJACENT TO REFUGE TRACK. WPC HOUSING SHOULD BE LOCATED ADJACENT TO SIGNAL HOUSING.
- COMMUNICATION EQUIPMENT WILL BE LOCATED WITHIN THE SIGNAL HOUSING
- WPC - WAYSIDE POWER CONTROL CABINET WILL HOUSE RTU (REMOTE TERMINAL UNIT) AND DC POWER SUPPLY UNIT FOR MOTOR OPERATED DISCONNECT SWITCHES.
- ACCESS ROADS 20' WIDE MINIMUM.
- VEHICLE ACCESS GATES 12' WIDE MINIMUM.

REV	DATE	BY	CHK	APP	DESCRIPTION

DESIGNED BY
H. GLICKENSTEIN
DRAWN BY
D. SOLTERO
CHECKED BY
E. MORTLOCK
IN CHARGE
R. SCHEDES
DATE
06/08/10



CALIFORNIA HIGH-SPEED TRAIN PROJECT
TYPICAL INTERLOCKING LAYOUT AT STATIONS

CONTRACT NO. 13259
DRAWING NO. TM 3.3.2-A
SCALE NTS
SHEET NO.

6/23/2010 2:02:24 PM T:\13259B Calif High Speed Rail\CADD\Directive Drawings\3.3.2\Working\3.3.2-B.dgn

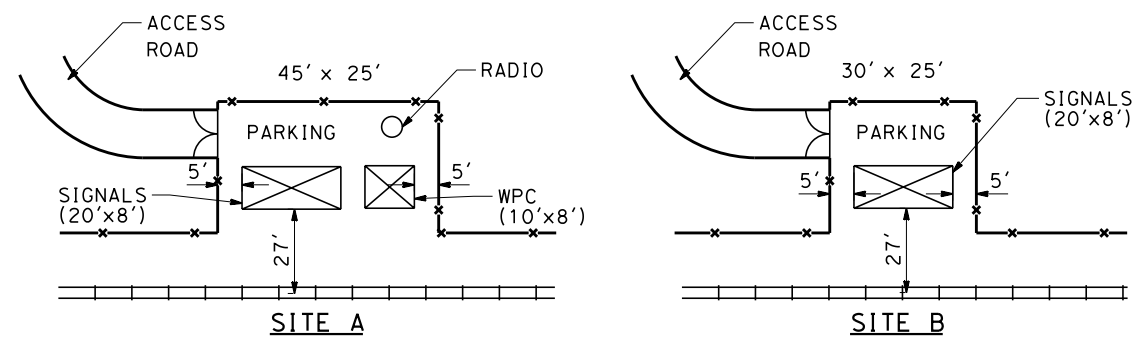
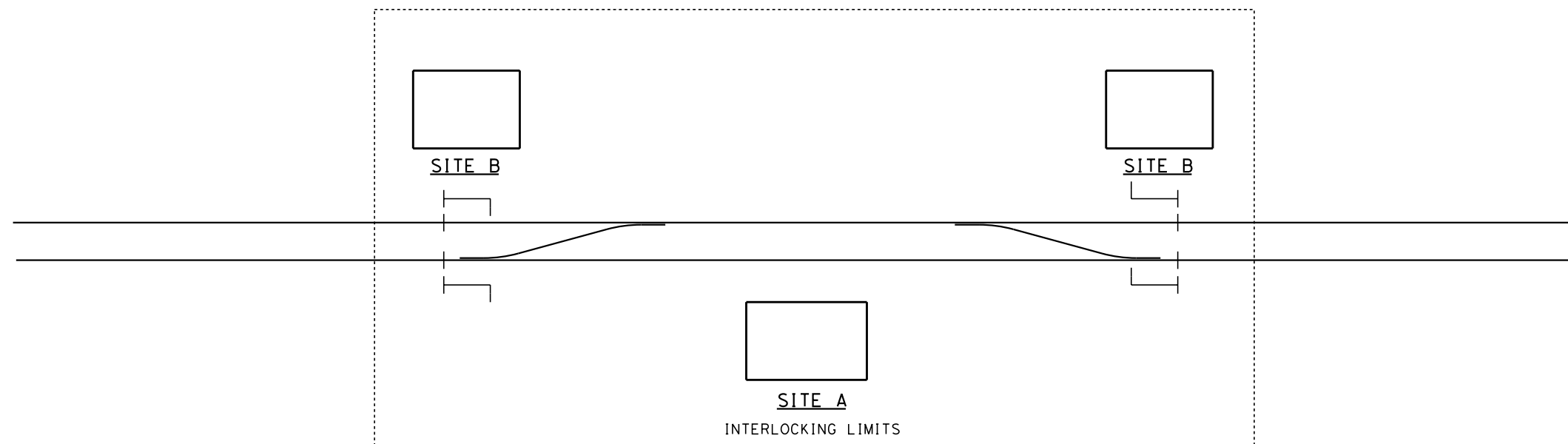

HOUSING WITHIN SITES

NOTES:

1. HOUSINGS MAY BE LOCATED ON EITHER SIDE OF THE TRACK BY DESIGNER PREFERENCE EXCEPT FOR HOUSINGS ADJACENT TO REFUGE TRACK. WPC HOUSING SHOULD BE LOCATED ADJACENT TO SIGNAL HOUSING.
2. COMMUNICATION EQUIPMENT WILL BE LOCATED WITHIN THE SIGNAL HOUSING
3. WPC - WAYSIDE POWER CONTROL CABINET WILL HOUSE RTU (REMOTE TERMINAL UNIT) AND DC POWER SUPPLY UNIT FOR MOTOR OPERATED DISCONNECT SWITCHES.
4. ACCESS ROADS 20' WIDE MINIMUM.
5. VEHICLE ACCESS GATES 12' WIDE MINIMUM.

REV	DATE	BY	CHK	APP	DESCRIPTION

DESIGNED BY
H. GLICKENSTEIN
DRAWN BY
D. SOLTERO
CHECKED BY
E. MORTLOCK
IN CHARGE
R. SCHEDES
DATE
06/08/10



CALIFORNIA HIGH-SPEED TRAIN PROJECT

TYPICAL UNIVERSAL INTERLOCKING LAYOUT

CONTRACT NO.
13259
DRAWING NO.
TM 3.3.2-B
SCALE
NTS
SHEET NO.

NOTE:

1. GUIDANCE GIVEN FOR MINIMUM CLEARANCE BETWEEN SIGNAL AND CENTERLINE OF TRACK. ACTUAL CLEARANCES SHALL COMPLY WITH TM 1.1.10.

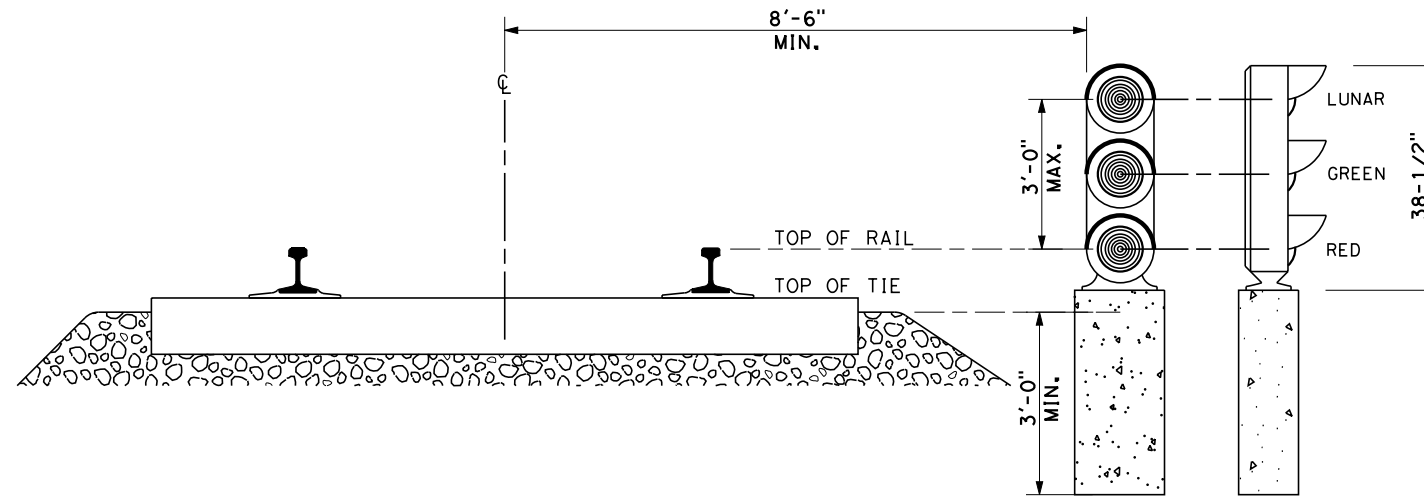

TYPICAL DWARF SIGNAL WITH 8-3/8" LENSES

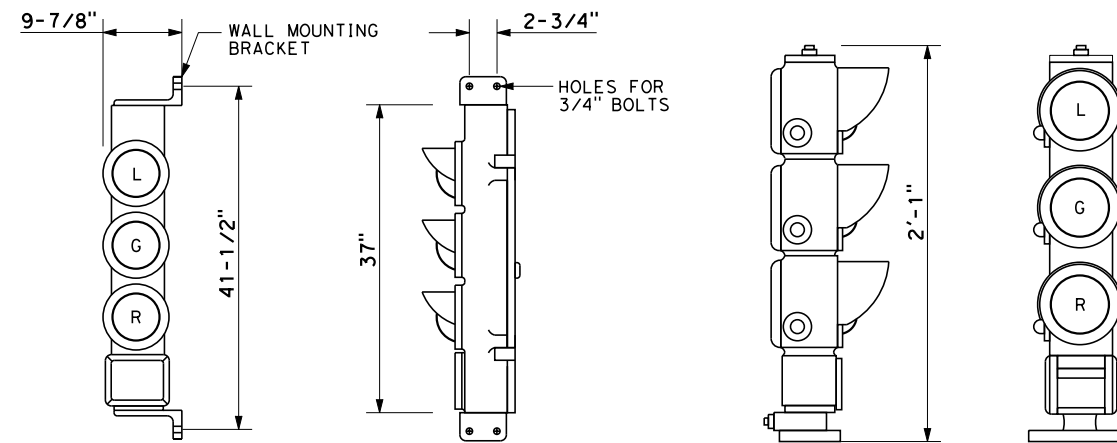

TYPICAL WALL - MOUNTED SIGNAL

TYPICAL LOW LEVEL SIGNAL

6/23/2010 2:03:39 PM T:\13259B Calif High Speed Rail\CADD\Directive Drawings\3.3.2\Working\3.3.2-C.dgn David

REV	DATE	BY	CHK	APP	DESCRIPTION

DESIGNED BY
H. GLICKENSTEIN
DRAWN BY
D. SOLTERO
CHECKED BY
E. MORTLOCK
IN CHARGE
R. SCHEDES
DATE
06/08/10



CALIFORNIA HIGH-SPEED TRAIN PROJECT

TYPICAL WAYSIDE LOW LEVEL SIGNAL

CONTRACT NO. 13259
DRAWING NO. TM 3.3.2-C
SCALE NTS
SHEET NO.

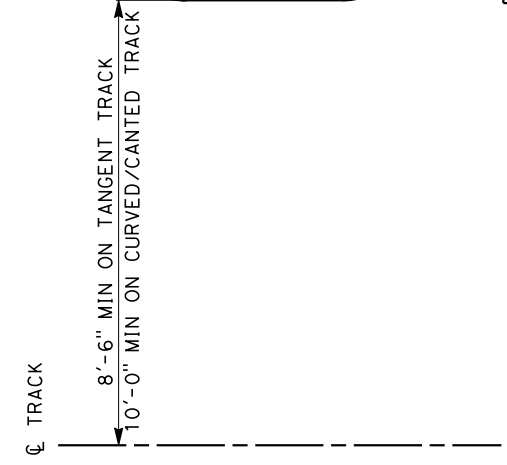
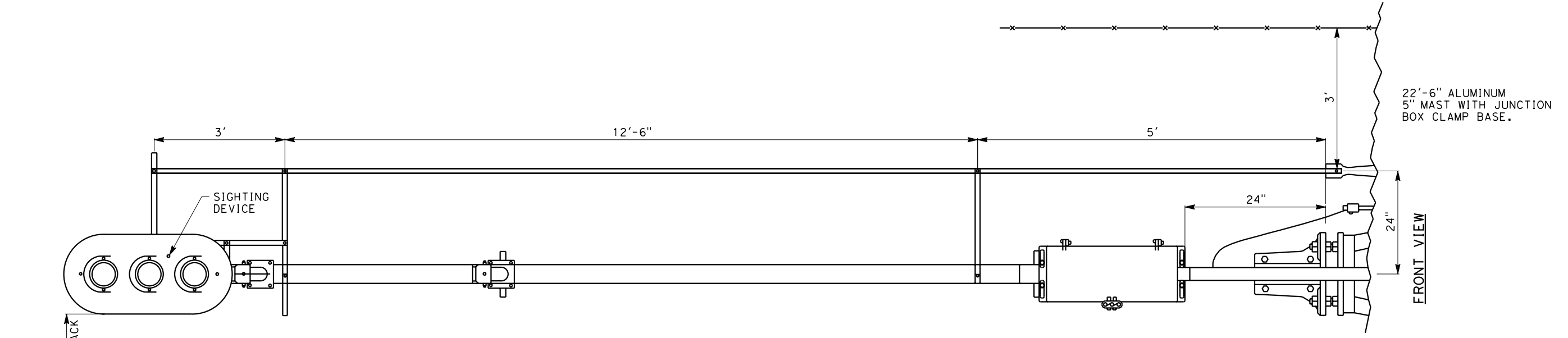
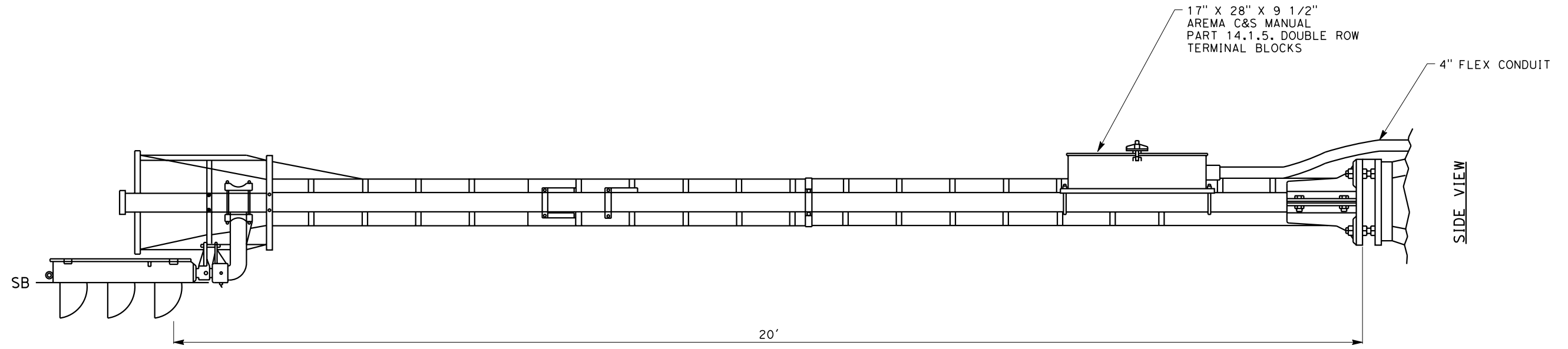

NOTE:

1. SIGNAL MUST BE EQUIPPED WITH LADDER GUARD AND LOCKING BRACKET. LADDER AND PLATFORM MUST MEET CURRENT OSHA REQUIREMENTS AND BE MOUNTED ON FIELD SIDE OF MAST.
2. PROVIDE A MIN. DISTANCE OF 3' FOR WALKWAY AROUND SIGNAL & LADDER.
3. GUIDANCE GIVEN FOR MINIMUM DISTANCE BETWEEN SIGNAL AND CENTERLINE OF TRACK. ACTUAL CLEARANCES SHALL COMPLY WITH TM 1.1.10.

6/23/2010 2:04:41 PM T:\13259B Calif High Speed Rail\CADD\Directive Drawings\3.3.2\Working\3.3.2-D.dgn

REV	DATE	BY	CHK	APP	DESCRIPTION

DESIGNED BY
H. GLICKENSTEIN
DRAWN BY
D. SOLTERO
CHECKED BY
E. MORTLOCK
IN CHARGE
R. SCHMEDES
DATE
06/08/10



CALIFORNIA HIGH-SPEED TRAIN PROJECT

TYPICAL GROUND MAST SIGNAL

CONTRACT NO.
13289
DRAWING NO.
TM 3.3.2-D
SCALE
NTS
SHEET NO.

6/23/2010 2:07:18 PM T:\13259B Calif High Speed Rail\CADD\Directive Drawings\3.3.2 Working\3.3.2-E.dgn

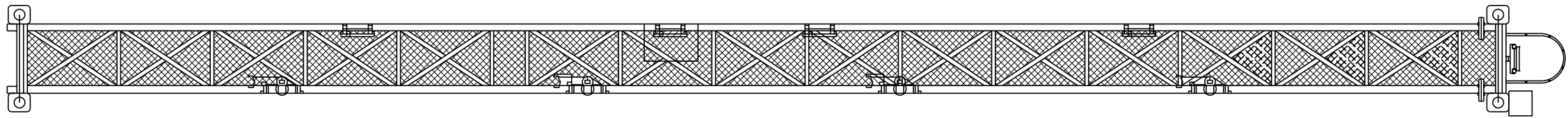

TOP VIEW

NOTE:

1. BASES OF BRIDGE MAST TO BE LEVEL WITH TOP OF HIGHEST RAIL AND IN LINE WITH OCS POLES. CLEARANCES INDICATED ARE ABSOLUTE MINIMUMS. SEE TM 1.1.10.
2. 41" X 73 3/4" X 24" FREE STANDING POWDER COATED STEEL JUNCTION CASE REQUIRED WHERE MAST MOUNTED JUNCTION CASE DOES NOT HAVE SUFFICIENT CAPACITY.
3. BRIDGE LADDERS AND CAGES SHALL MEET ALL OSHA REQUIREMENTS.

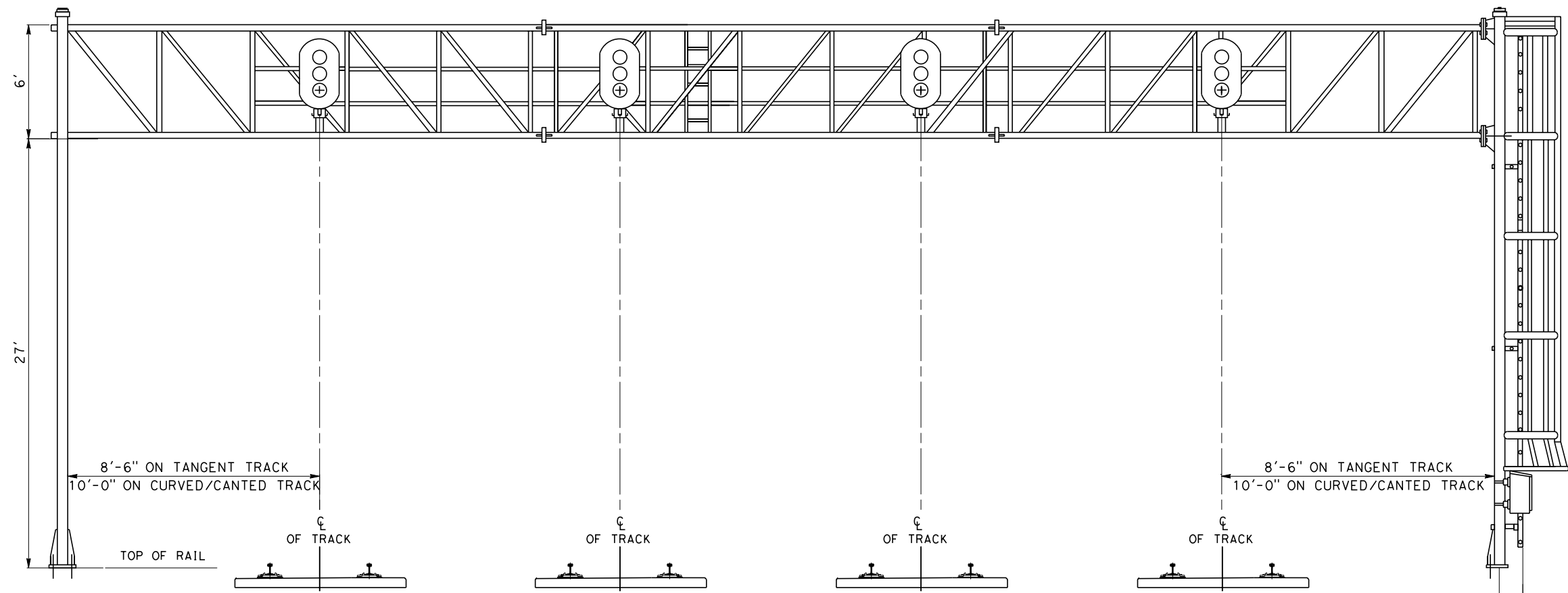

FRONT VIEW

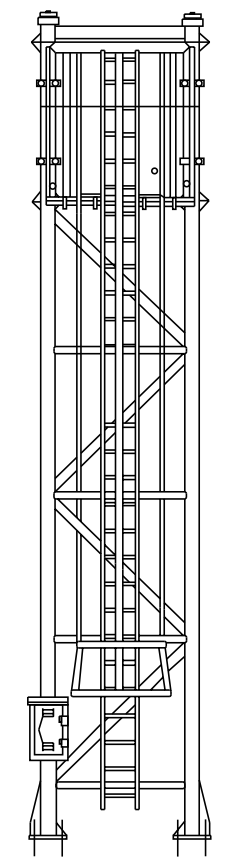

SIDE VIEW

FOOTING REQUIREMENTS:

1. A DISTANCE OF 3' SHALL BE PROVIDED BETWEEN BRIDGE VERTICAL SECTIONS AND LADDER TO FENCE OR OTHER OBSTRUCTIONS

REV	DATE	BY	CHK	APP	DESCRIPTION

DESIGNED BY
H. GLICKENSTEIN
DRAWN BY
D. SOLTERO
CHECKED BY
E. MORTLOCK
IN CHARGE
R. SCMEDES
DATE
06/08/10



CALIFORNIA HIGH-SPEED TRAIN PROJECT

TYPICAL SIGNAL BRIDGE

CONTRACT NO.
13289
DRAWING NO.
TM 3.3.2-E
SCALE
NTS
SHEET NO.

6/11/2010 1:20:13 PM T:\13259B Calif High Speed Rail\CADD\Directive Drawings\3.3.2\Working\3.3.2-F.dgn

BRIDGE
 TOTAL WEIGHT: 10700#
 8- 1-1/2" X 84" BOLTS
 BOLT PATTERN:
 19" X 19"

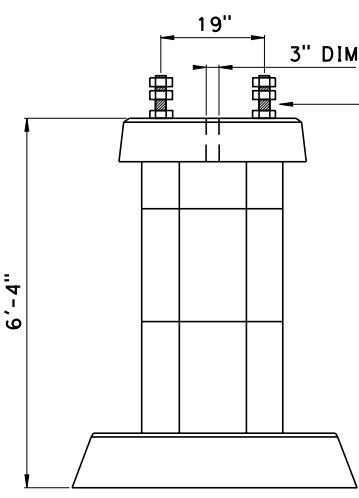
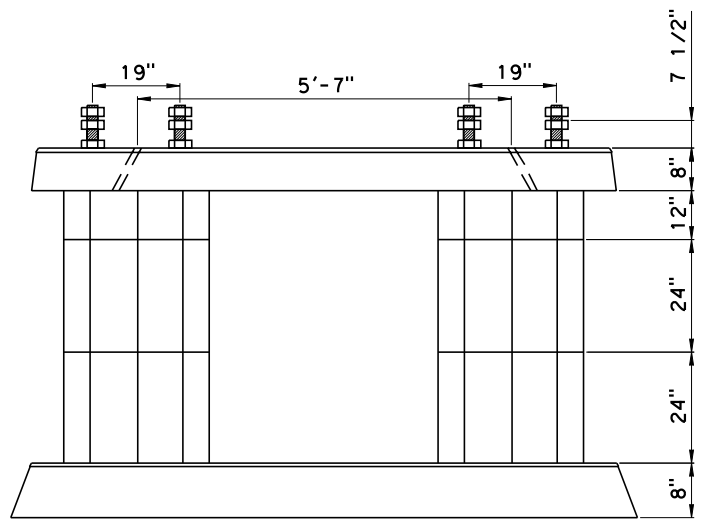
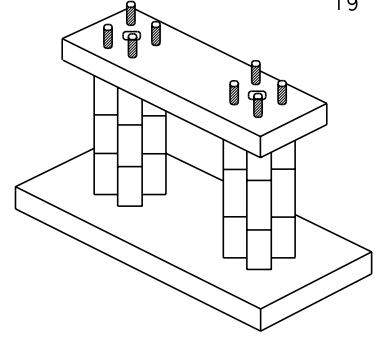
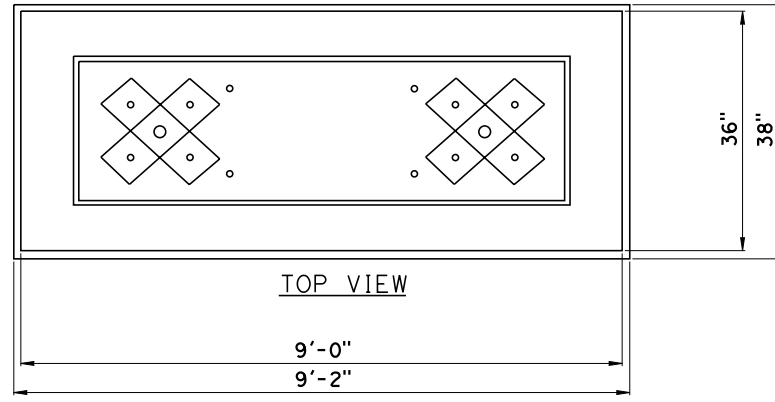

MIN. 1" SPACE BETWEEN NUTS

NOTE:

1. CONCRETE SHALL BE IN ACCORDANCE WITH AREMA SPECIFICATIONS FOR CONCRETE STRUCTURES AND FOUNDATIONS.
2. TOP AND BOTTOM SURFACES OF ALL PARTS SHALL BE FLAT AND PARALLEL.
3. STEEL PLATE AND NUT ASSEMBLIES SHALL BE PLACED SUCH THAT WHEN ASSEMBLED, THE BOLTS WILL BE PERPENDICULAR TO THE BASE PLATE UPPER SURFACE WITHIN ONE DEGREE OF PERPENDICULAR.
4. NUT ASSEMBLY SHALL BE ARRANGED SO THAT ONE NUT AND FLAT WASHER WILL BE USED TO SECURE ANCHOR BOLTS TO FOUNDATION. ANOTHER NUT AND FLAT WASHER WILL BE USED TO LEVEL THE BRIDGE AND OR CANTILEVER MAST AND A THIRD NUT/WASHER COMBINATION TO SECURE MAST IN PLACE.
5. PROVIDE A MINIMUM OF 3' FOR WALKWAY AROUND BRIDGE VERTICAL SECTIONS AND LADDER TO FENCE OR OTHER OBSTRUCTIONS

FRONT VIEW

SIDE VIEW

SIGNAL BRIDGE FOUNDATION

REV	DATE	BY	CHK	APP	DESCRIPTION

DESIGNED BY
 H. GLICKENSTEIN
 DRAWN BY
 D. SOLTERO
 CHECKED BY
 E. MORTLOCK
 IN CHARGE
 R. SCHMEDES
 DATE
 06/08/10



CALIFORNIA HIGH-SPEED TRAIN PROJECT

TYPICAL SIGNAL BRIDGE FOUNDATION

CONTRACT NO. 13259
DRAWING NO. TM 3.3.2-F
SCALE NTS
SHEET NO.