

California High-Speed Train Project



TECHNICAL MEMORANDUM

Traction Power Facilities General Standardization Requirements TM 3.1.1.3

Prepared by: Signed document on file 04 Jun 10
Vinod Sibal Date

Checked by: Signed document on file 07 Jun 10
Richard Schmedes Date

Approved by: Signed document on file 10 Jun 10
Ken Jong, PE, Engineering Manager Date

Released by: Signed document on file 11 Jun 10
Anthony Daniels, Program Director Date

Revision	Date	Description
0	01 Aug 08	Initial Release, R0
1	03 Jun 09	Paralleling Station sites revised to be at five-mile intervals; agency terminology updates
2	10 Jun 10	Update Traction Power Facility footprint requirement, abbreviation updates, and additional requirements added

Note: Signatures apply for the latest technical memorandum revision as noted above.

This document has been prepared by *Parsons Brinckerhoff* for the California High-Speed Rail Authority and for application to the California High-Speed Train Project. Any use of this document for purposes other than this Project, or the specific portion of the Project stated in the document, shall be at the sole risk of the user, and without liability to PB for any losses or injuries arising for such use.

System Level Technical and Integration Reviews

The purpose of the review is to ensure:

- Technical consistency and appropriateness
- Check for integration issues and conflicts

System level reviews are required for all technical memorandums. Technical Leads for each subsystem are responsible for completing the reviews in a timely manner and identifying appropriate senior staff to perform the review. Exemption to the system level technical and integration review by any subsystem must be approved by the Engineering Manager or the System Integration Manager.

System Level Technical Reviews by Subsystem:

Systems:	<u>NOT REQUIRED</u> Print Name:	<u>DD Month YY</u> Date
Infrastructure:	<u><i>Signed document on file</i></u> John Chirco	<u>23 May 10</u> Date
Operations:	<u>NOT REQUIRED</u> Print Name:	<u>DD Month YY</u> Date
Maintenance:	<u>NOT REQUIRED</u> Print Name:	<u>DD Month YY</u> Date
Rolling Stock:	<u>NOT REQUIRED</u> Print Name:	<u>DD Month YY</u> Date

Note: Signatures apply for the technical memorandum revision corresponding to revision number in header and as noted on cover.

TABLE OF CONTENTS

- ABSTRACT 1**

- 1.0 INTRODUCTION 2**
 - 1.1 PURPOSE OF TECHNICAL MEMORANDUM 2
 - 1.2 STATEMENT OF TECHNICAL ISSUE 2
 - 1.3 GENERAL INFORMATION 2
 - 1.3.1 Definition of Terms 2
 - 1.3.2 Units 4

- 2.0 DEFINITION OF TECHNICAL TOPIC..... 5**
 - 2.1 GENERAL..... 5
 - 2.1.1 CHSTP System Design Considerations 5
 - 2.1.2 CHSTP System Design Parameters 5

- 3.0 ASSESSMENT / ANALYSIS..... 6**
 - 3.1 GENERAL..... 6
 - 3.2 ASSESSMENT 6
 - 3.2.1 Analysis 6
 - 3.2.2 CHSTP Standard 6

- 4.0 SUMMARY AND RECOMENDATIONS 7**
 - 4.1 GENERAL..... 7

- 5.0 SOURCE INFORMATION AND REFERENCES 9**
 - 5.1 GENERAL..... 9

- 6.0 DESIGN MANUAL CRITERIA 10**
 - 6.1 TRACTION POWER FACILITIES GENERAL STANDARDIZATION REQUIREMENTS 10
 - 6.1.1 Footprint 10
 - 6.1.2 Equipment and Vehicle Access 10
 - 6.1.3 Approximate Spacing 10
 - 6.1.4 Maximum Distance from Right of Way 10
 - 6.1.5 Additional Requirements 10
 - 6.1.6 Location along the Right of Way 11
 - 6.2 WAYSIDE POWER CONTROL CUBICLES (WPC) 11

ABSTRACT

In order to provide a dependable and cost effective traction power supply system (TPS) for the California High-Speed Train Project (CHSTP) the placement, size, and power conditioning of the traction power facilities (TPF) will be a priority during all phases of the design process. To enhance safe working conditions, simplify Operating and Maintenance procedures, and minimize the number and type of spare parts required, the layout and rating of the traction power facilities will be standardized as much as is feasible.

The purpose of this technical memorandum is to review best practices and provide design requirements that specify these standardization requirements, and to list applicable industry standards, codes, and guidelines to:

- Define the physical footprint of each type of traction power facility (substation - SS with high voltage utility circuits, switching station - SWS, and paralleling station - PS).
- Define the land needed to be obtained to allow installation of each type of traction power facility.

Note: All TPF must preferably, be located within 100 feet of the CHSTP alignment to minimize the length of the duct banks between the TPF and the track.

- Define the requirements for access and maintenance of the TPF.
- Allow for the consistent sizing and standardization of all TPF equipment including transformers, switchgear, and bus systems.
- Allow for standardized duct banks and cable sizing, and routing

Note: The last two items are not discussed in the text and will be defined and discussed when the traction power equipment is identified.

Development of the general design criteria for the traction power supply system will include review and assessment of, but not limited to, the following:

- Standardized layouts and equipment configurations for each type of traction power facility.
- Size of sites required for each type of traction power facility, including vehicle access.
- Existing FRA, CPUC General Orders, NESC, IEEE, NFPA, and AREMA guidelines where applicable to the traction power facility equipment and sites.
- The gathering and analysis of existing international standards, codes, best practices, and guidelines used on existing high-speed train systems for applicability to CHSTP traction power facilities.

1.0 INTRODUCTION

The California High-Speed Rail Authority (CHSRA) is in the process of designing and building a world class high-speed train system to connect the major cities of California. In the final alignment for the California High Speed Train Project (CHSTP), consideration must be given to the availability of the space required to accommodate the three types of traction power facilities (TPF) namely, substations, switching stations and paralleling stations. The space, electrical feeds, and proximity to the alignment has been addressed in an effort to standardize these sites as much as possible. Standardization will shorten the design time; however, the dimensions of available sites and their orientation to the rail right-of-way (ROW) and adjacent roadways may require site specific layouts to be developed.

This memorandum defines general space requirements for each of the three types of sites required on the CHSTP, i.e., substation with high voltage utility circuits, switching station, and paralleling station. This includes site requirements such as access for initial site work and equipment installation, parking for maintenance vehicles, and access for emergency vehicles.

A definition of generic footprints for each type of TPF has been given as well as the conceptual layout of the major items of equipment. The dimensions of specific equipment has not been included as a part of this memorandum but sizing of the station sites takes into consideration the largest equipment sizes presently used in similar high-speed rail systems.

1.1 PURPOSE OF TECHNICAL MEMORANDUM

The purpose of this document is to define space and equipment requirements for each of the three types of traction power facilities.

1.2 STATEMENT OF TECHNICAL ISSUE

In order for the section designers for each segment of the California High-Speed Train Project to assess the land requirements for the traction power supply system (TPS), this memorandum addresses the footprint of each type of TPF, the access requirements for installation, maintenance and emergency vehicles, and any other areas that might be need to be considered at individual sites.

NOTE: All TPF should preferably, be located within 100 feet of the high-speed rail alignment to minimize the length of the duct banks between the TPF and the track.

1.3 GENERAL INFORMATION

The CHSTP will have an end-to-end length of approximately 800 miles. It will be designed and built in segments, possibly by different entities, over a number of years. Although the civil and structural elements of the line may vary in the different segments, the "system" elements must be consistent over the full length of the line. This technical memorandum provides the basic information and criteria to be used for the TPF sites and equipment layout. This information is applicable to all main line segments of the CHSTP.

1.3.1 Definition of Terms

The following technical terms, acronyms, phrases, and terminology have specific connotations with regard to traction power supply system for the California High-Speed Train Project:

- Technical Terms

Autotransformer (AT): Apparatus which helps boost the OCS voltage and reduce the running rail return current in the 2 X 25 kV autotransformer feed configuration. It uses a single winding having three terminals. The intermediate terminal located at the midpoint of the winding is connected to the rail and the two outer terminals are connected to the catenary and negative feeder wires.

Negative Feeder (NF): Negative feeder is an overhead conductor supported on the same structure as the OCS, and is at a voltage 25 kV with respect to ground but 180° out-of-phase with respect to the voltage on the OCS, i.e. the voltage between the OCS and the negative feeder is 50 kV nominal. The negative feeder connects successive feeding points, and is connected to one terminal of an autotransformer in the traction power facilities via a circuit breaker or disconnect switch. At these facilities, the other terminal of the autotransformer is connected to a catenary section or sections, via circuit breakers or disconnects.

Power Transformer: A device which transforms power on an AC system from one voltage level to another (e.g., from 115 kV to 25 kV).

Traction Power Facilities (TPF): A general term that encompasses substations (SS), switching stations (SWS) and paralleling stations (PS).

Traction Power Supply System (TPS): The railway electrical distribution network used to provide energy to high-speed electric trains, which comprises of the following three types of traction power facilities in addition to connections to the OCS and the traction return and grounding system:

1. **Substation (SS)** at which power is converted from high voltage to a nominal 2X25 kV railway traction voltage and distributed to the overhead contact system (OCS) and the negative feeders, including incoming high voltage (115/230 kV) supplies from power supply utility's network,
2. **Switching Station (SWS):** An installation at which electrical energy can be supplied to an adjacent, but normally separated electrical section during contingency power supply conditions. It also acts as a PS, and
3. **Paralleling Station (PS):** An installation which helps boost the OCS voltage and reduce the running rail return current by means of the autotransformer feed configuration. The negative feeders and the catenary conductors are connected to the two outer terminals of the autotransformer winding at this location. OCS sections can be connected in parallel at PS locations.

Wayside Power Control Cubicle (WPC): A wayside installation that houses remote terminal unit (RTU) and dc power supply unit for motor operated disconnect switches at locations other than traction power facilities.

- Acronyms

ac	Alternating Current
ACSR	Aluminium Conductor Steel Reinforced
AEC	Aerial Earth (Ground) Conductor
AT	Autotransformer
BEC	Buried Earth (Ground) Conductor
CHSRA	California High Speed Rail Authority
CHSTP	California High Speed Train Project
CPUC	California Public Utility Commission
Cu	Copper
CW	Contact Wire
dc	Direct Current
HD	Hard Drawn
HV	High Voltage
IMP	Impedance Bond
LV	Low Voltage
MW	Messenger Wire
NF	Negative Feeder

NIST	National institute of Standards and Technology
OCS	Overhead Contact System
PG&E	Pacific Gas and Electric Company
PS	Paralleling Station with Autotransformer(s)
SCE	Southern California Edison
SDB	System Duct Bank
SDG&E	San Diego Gas and Electric
SS	Substation (with HV Utility Supply)
SWS	Switching Station with Autotransformer(s)
TPF	Traction Power Facility (ies)
TPS	Traction Power Supply System
WPC	Wayside Power Control Cubicle

1.3.2 Units

The California High-Speed Train Project (CHSTP) is based on U.S. Customary Units consistent with guidelines prepared by the California Department of Transportation and defined by the National Institute of Standards and Technology (NIST). U.S. Customary Units are officially used in the United States, and are also known in the U.S. as “English” or “Imperial” units. In order to avoid confusion, all formal references to units of measure should be made in terms of U.S. Customary Units.

2.0 DEFINITION OF TECHNICAL TOPIC

2.1 GENERAL

The following sections contain the design considerations that were assessed in determining the land space requirements to be used for the CHSTP TPF sites, and the local, state, or federal codes that each site must meet.

2.1.1 CHSTP System Design Considerations

The CHSTP system will require locating acceptable plots of land for the construction of and access to three types of TPF. This memorandum considers existing high-speed train systems around the world and their TPF equipment. It also highlights that local, state, and federal emergency vehicle code requirements as applicable and maintenance vehicle access requirements must be investigated for each individual site. The TPF sites have been sized to include:

- Substation with HV utility supply circuits and switchgear
- Switching Stations with autotransformers
- Paralleling Stations with autotransformers

With these “standardized” traction power facility footprints, where site conditions permit, the segment designers will be able design the ductbanks, cable sizing, and cable routing in a way that allows a repetitive design and standardization of equipment locations throughout the CHSTP. While the specifics of the equipment are not known at this time, installed equipment will include but not be limited to:

- Power Transformers
- Autotransformers
- Station Service Transformers/Auxiliary Transformers
- Circuit Breakers
- Disconnect Switches
- Bus Bar Systems
- Switchgear Rooms
- Control Rooms
- Control Panels
- Metering
- Cable Trays/Ducting
- Ground Grids
- Fencing

2.1.2 CHSTP System Design Parameters

- Nominal system voltage – 25kV
- Minimum utility supply voltage – 115 kV at SS
- Redundant utility supply at SS
- Redundant power supply transformers at SS
- No degradation of train performance during Single Contingency Power Supply conditions
- No stranded trains during Second Contingency Power Supply conditions
- Local, state, and federal emergency vehicle access requirements
- Operation and maintenance access requirements
- Traction power facility spacing requirements along right-of-way (each station type)

3.0 ASSESSMENT / ANALYSIS

3.1 GENERAL

Traction power facility locations and sizes are critical to segment designers in their search for adequate land close to the CHSTP alignment, and for substations' access to HV utility supply circuits. The attached drawings define the site size requirements for each type of TPF and show a conceptual layout for equipment and vehicle access.

Note: The drawings show both the minimum dimensions of the fenced area required for the conceptual layout shown and the proposed dimensions for a typical site.

3.2 ASSESSMENT

3.2.1 Analysis

The information included in this technical memorandum is to allow the definition of land space and access required along the right-of-way to allow the construction and maintenance of the three types of traction power facilities required for the traction power supply system. The site sizing was based on:

- HV utility supply circuits for the supply stations 115kV or higher
- Each substation having redundant HV utility supply circuits originating from different sources
- Each substation having redundant power supply transformers each sized for the full-load of the substation
- Switching stations having four autotransformers
- Paralleling stations having two autotransformers
- Substation, switching stations, and paralleling stations rated and located in accordance with the findings of the traction power supply computer load-flow simulations
- Traction power facility ratings and configuration for each type of station, i.e., substation, switching station, and paralleling station, being standardized as much as is feasible
- The ultimate level of service to be supported by each section of the traction power supply system.
- The location of existing HV utility circuits
- The location and availability of acceptable sites for the TPF.
- Site areas preferably, within 100' of CHSTP alignment
- Provision of a separate communications room (20' x 15') within and on the periphery of every TPF to house communications interface equipment for SCADA system and other wayside communications equipment, with a separate access

Available sites will be verified as being acceptable locations when traction power simulations are performed and the required performance of the traction power supply system is demonstrated.

3.2.2 CHSTP Standard

Because at this time there are no specific North American Federal or State of California standards or criteria for 25kV, 60 Hz electrification systems, the criteria of other countries' high-speed rail systems, NESC, NFPA 130, State of California Public Utility Commission (CPUC) General Orders (GO), and CFR 46 requirements were reviewed during the development of this technical memorandum.

4.0 SUMMARY AND RECOMENDATIONS

4.1 GENERAL

It is recommended that the following general dimensions be used for the sites for each type of traction power facility:

- Traction power substation with two power transformers (Figure 1): 200 ft X 160 ft
- Traction power substation with three power transformers (Figure 2): 200 ft X 210 ft
- Traction power switching station (Figure 3): 160 ft X 90 ft
- Traction power paralleling station (Figure 4): 120 ft X 80 ft

As a general guideline for locating sites:

- The candidate locations should be assessed and environmentally cleared for a larger site than the recommended general dimensions to accommodate refinement of site layout in subsequent design phases.
- Substation sites should be spaced approximately every 30 miles.
- Switching station sites should be located approximately midway between substation sites.
- Paralleling station sites should be located at approximately five-mile intervals between switching station and substation sites.
- In general, all substations will be configured with two power transformers although there may be some locations that shall require a substation configuration with three power transformers.
- With a view to preventing stalling of trains at the phase-breaks, substations and switching stations should preferably not be located within a 2-mile distance from the nearest end of any railway station or wayside crossover.
- These are typical footprints of different traction power facilities. Orientation of the TPF with respect to tracks, locations of utility supply circuits, equipment, and road access shall be determined on a site-by-site basis.
- Added space may be required adjacent to the substation site if HV supply circuits must be constructed to serve the site. These requirements have been detailed in another TM (TM 3.1.5.3).
- Access to each site will be required both during construction and for operating and maintenance purposes. Heavy equipment must be installed initially and may be replaced during service.
- Access roads between public roadways and each TPF site shall be constructed and configured to allow periodic access to low-load type vehicles, and routine access and parking for maintenance type vehicles.
- If the traction power facility has to be located in the proximity of or beneath high-speed train tracks located on aerial guideways it shall be ensured that the main power transformers and autotransformers are located in an open area (shall not be located underneath structures), and that proper clearances are available for the main gantry (main gantry dimensions are given in the above four drawings).
- There shall be a strain gantry located within the railroad right-of-way (ROW) parallel to and on the opposite side of the track away from the TPF, with footprints exactly equal to that of the main gantry (main gantry dimensions are given in the above four drawings).
- If the TPF is located away from the track, the main gantry will be located within the railroad ROW, parallel to and towards TPF side of the track. In this case an additional strip of land (40' wide for SS and SWS, and 30' wide for PS) will be required for laying

duct banks and manholes for laying power cables from the TPF to the main gantry. Typical layouts of duct banks and manholes and conceptual TPF locations are presented in the following drawings:

- Typical Duct Bank Details (Figure 5)
- Typical manhole Details (Figure 6), and
- Alternative Conceptual Locations of Traction power facilities Relative to Railroad ROW (Figure 7).

In addition to these TPF there will be many wayside power control cubicles (WPC) located at railway stations and on the wayside. Footprints of WPC are given in TM 3.3.2 (Directive Drawings TM 3.3.2 – A and TM 3.3.2 – B)

5.0 SOURCE INFORMATION AND REFERENCES

5.1 GENERAL

1. French TGV System
2. Japanese Shinkansen System
3. Taiwan HSR System
4. German ICE-3 HSR System
5. NEC, Boston to New Haven Electrified Line
6. Caltrain Electrification Project Design Documents
7. National Electrical Safety Code
8. IEEE – 80: Guide for Safety in AC Substation Grounding
9. California Public Utilities Commission (CPUC) General Orders

6.0 DESIGN MANUAL CRITERIA

6.1 TRACTION POWER FACILITIES GENERAL STANDARDIZATION REQUIREMENTS

6.1.1 Footprint

Approximate footprints for the traction power facilities:

1. Traction power substation (2 power transformers) with two high voltage utility supply circuits – 200 ft X 160 ft
2. Traction power substation (3 power transformers) with two high voltage utility supply circuits – 200 ft X 210 ft
3. Traction power switching stations with 4 - 2 x 25kV autotransformers – 160 ft X 90 ft
4. Traction power paralleling stations with 2 – 2 x 25kV autotransformers – 120 ft X 80 ft

These are typical footprints of different traction power facilities. Orientation of the TPF with respect to tracks, locations of utility supply circuits, equipment, and road access shall be determined on a site-by-site basis.

In general, all substations will be configured with two power transformers although there may be some locations that shall require a substation configuration with three power transformers.

6.1.2 Equipment and Vehicle Access

Access to each site shall be required both during construction and for operation and maintenance purposes. Access roads between public roadways and each TPF site shall be constructed and configured to allow periodic access to low-load type of vehicles, and routine access and parking for maintenance type vehicles. The conceptual layouts of equipment and vehicle access are shown in Figures 1~4.

6.1.3 Approximate Spacing

1. Substation sites at 30 mile intervals along the HSR right-of-way
2. Switching station sites midway between substation sites
3. Paralleling station Sites at approximately five-mile intervals between switching station and substation sites
4. With a view to preventing stalling of trains at the phase-breaks, substations and switching stations should preferably not be located within a 2-mile distance from the nearest end of any railway station or wayside crossover.

6.1.4 Maximum Distance from Right of Way

The trackside fence for all types of traction power facilities should preferably be located not more than 100 feet from the CHSR right of way.

6.1.5 Additional Requirements

1. The candidate locations should be assessed and environmentally cleared for a larger site than the recommended general dimensions to accommodate refinement of site layout in subsequent design phases.
2. Added space may be required adjacent to the substation site if HV supply circuits must be constructed to serve the site. These requirements have been detailed in another TM (TM 3.1.5.3).
3. If the traction power facility has to be located in the proximity of or beneath high-speed train tracks located on aerial guideways it shall be ensured that that the main power transformers and autotransformers are located in an open area (shall not be located underneath

structures), and that proper clearances are available for the main gantry (main gantry dimensions are given in the above four drawings).

4. Where practical,
 - Candidate sites should be on a level grade to eliminate need for extensive grading and construction of retaining walls
 - Candidate sites should be located away from residential property
 - Roadways access should be provided between the TPF and the high-speed trains ROW to allow for consolidation of maintenance and emergency access locations.
5. There shall be a strain gantry located within the railroad right-of-way (ROW) parallel to and on the opposite side of the track away from the TPF, with footprints exactly equal to that of the main gantry (main gantry dimensions are given in the above four drawings).
6. If the TPF is located away from the track, the main gantry will be located within the railroad ROW, parallel to and towards TPF side of the track. In this case an additional strip of land (40' wide for SS and SWS, and 30' wide for PS) will be required for laying duct banks and manholes for laying power cables from the TPF to the main gantry. Typical layouts of duct banks and manholes and conceptual TPF locations are presented in the following drawings:
 - Typical Duct Bank Details (Figure 5)
 - Typical manhole Details (Figure 6), and
 - Alternative Conceptual Locations of Traction power facilities Relative to Railroad ROW (Figure 7).

6.1.6 Location along the Right of Way

Once preliminary site locations have been selected Traction Power Simulations will be performed to confirm that the spacing and locations are acceptable for the required performance of the Traction Power Supply System.

6.2 WAYSIDE POWER CONTROL CUBICLES (WPC)

In addition to these TPF there will be many wayside power control cubicles (WPC) located at railway stations and on the wayside. The requirement and the footprints of WPC are given in TM 3.3.2 (Directive Drawings TM 3.3.2 – A and TM 3.3.2 – B). Every WPC shall have a footprint of 10' x 8'. The number of WPC shall be as following:

- At every railway station including the universal crossovers on both ends – 6
- At every wayside universal crossover – 1

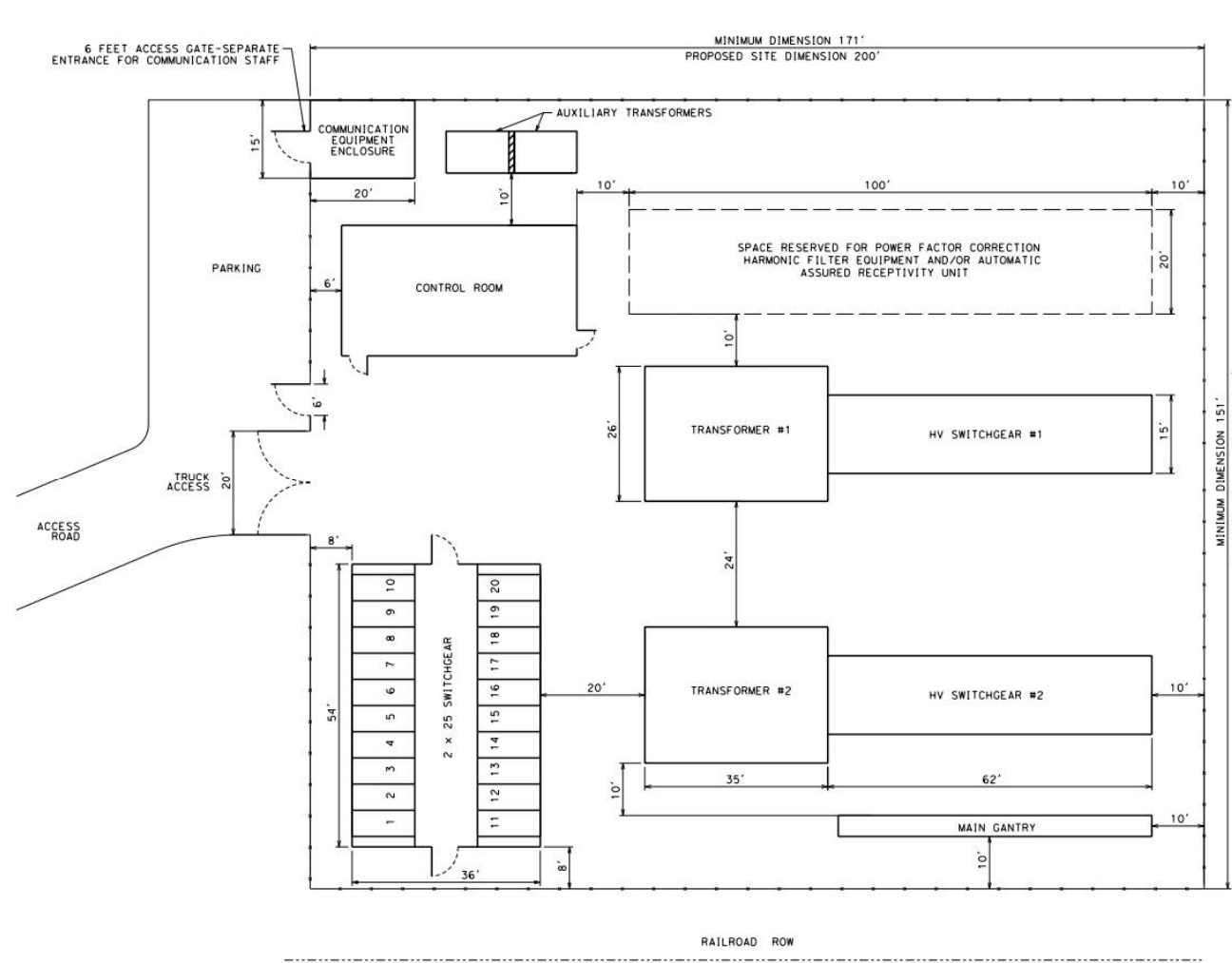

NOTES:

1. THIS IS A TYPICAL LAYOUT AND THE ORIENTATION OF THE STATION WITH RESPECT TO TRACK, LOCATION OF UTILITY SUPPLY CIRCUITS, EQUIPMENT, AND ROAD ACCESS TO BE DETERMINED ON A SITE-BY-SITE BASIS.
2. THE MAIN GANTRY POSITION SHALL BE PARALLEL TO AND ADJACENT TO THE TRACK.
3. THERE WILL BE A STRAIN GANTRY LOCATED WITHIN THE RAILROAD RIGHT-OF-WAY (ROW), PARALLEL TO AND ON THE OPPOSITE SIDE OF THE TRACK WITH FOOTPRINTS EXACTLY EQUAL TO THAT OF THE MAIN GANTRY.
4. IF THE TRACTION POWER FACILITY (TPF) IS LOCATED AWAY FROM THE TRACK, THE MAIN GANTRY WILL BE LOCATED WITHIN THE RAILROAD ROW, PARALLEL TO AND TOWARDS TPF SIDE OF THE TRACK. IN THIS CASE AN ADDITIONAL 40' WIDE STRIP OF LAND WILL BE REQUIRED FROM THE TPF TO THE RAILROAD ROW FOR LAYING UNDERGROUND DUCT BANKS AND MANHOLES.
5. FOR DUCT BANK AND MANHOLE DETAILS, SEE DWG. TM 3.1.1.3-E AND TM 3.1.1.3-F.
6. THE COMMUNICATION EQUIPMENT ROOM SHALL HOUSE COMMUNICATION INTERFACE EQUIPMENT FOR SCADA SYSTEM AND OTHER WAYSIDE COMMUNICATION EQUIPMENT.
7. THE GANTRIES SHALL BE 40 FEET HIGH.



CONCEPTUAL LAYOUT TRACTION POWER SUBSTATION WITH 2 HIGH VOLTAGE TRANSFORMERS - FIGURE 1

NOTES:

1. THIS IS A TYPICAL LAYOUT AND THE ORIENTATION OF THE STATION WITH RESPECT TO TRACK, LOCATION OF UTILITY SUPPLY CIRCUITS, EQUIPMENT, AND ROAD ACCESS TO BE DETERMINED ON A SITE-BY-SITE BASIS.
2. THERE IS A PROVISION FOR INSTALLING TWO MAIN GANTRIES FOR FACILITATING CONNECTIONS WITH OVERHEAD CONTACT SYSTEM OF DIFFERENT SECTIONS.
3. THERE WILL BE A STRAIN GANTRY LOCATED WITHIN THE RAILROAD RIGHT-OF-WAY (ROW), PARALLEL TO AND ON THE OPPOSITE SIDE OF THE TRACK WITH FOOTPRINTS EXACTLY EQUAL TO THAT OF THE MAIN GANTRY.
4. IF THE TRACTION POWER FACILITY (TPF) IS LOCATED AWAY FROM THE TRACK, THE MAIN GANTRY WILL BE LOCATED WITHIN THE RAILROAD ROW, PARALLEL TO AND TOWARDS TPF SIDE OF THE TRACK. IN THIS CASE AN ADDITIONAL 40' WIDE STRIP OF LAND WILL BE REQUIRED FROM THE TPF TO THE RAILROAD ROW FOR LAYING UNDERGROUND DUCT BANKS AND MANHOLES.
5. FOR DUCT BANK AND MANHOLE DETAILS, SEE DWG. TM 3.1.1.3-E AND TM 3.1.1.3-F.
6. THE COMMUNICATION EQUIPMENT ROOM SHALL HOUSE COMMUNICATION INTERFACE EQUIPMENT FOR SCADA SYSTEM AND OTHER WAYSIDE COMMUNICATION EQUIPMENT.
7. THE GANTRIES SHALL BE 40 FEET HIGH.

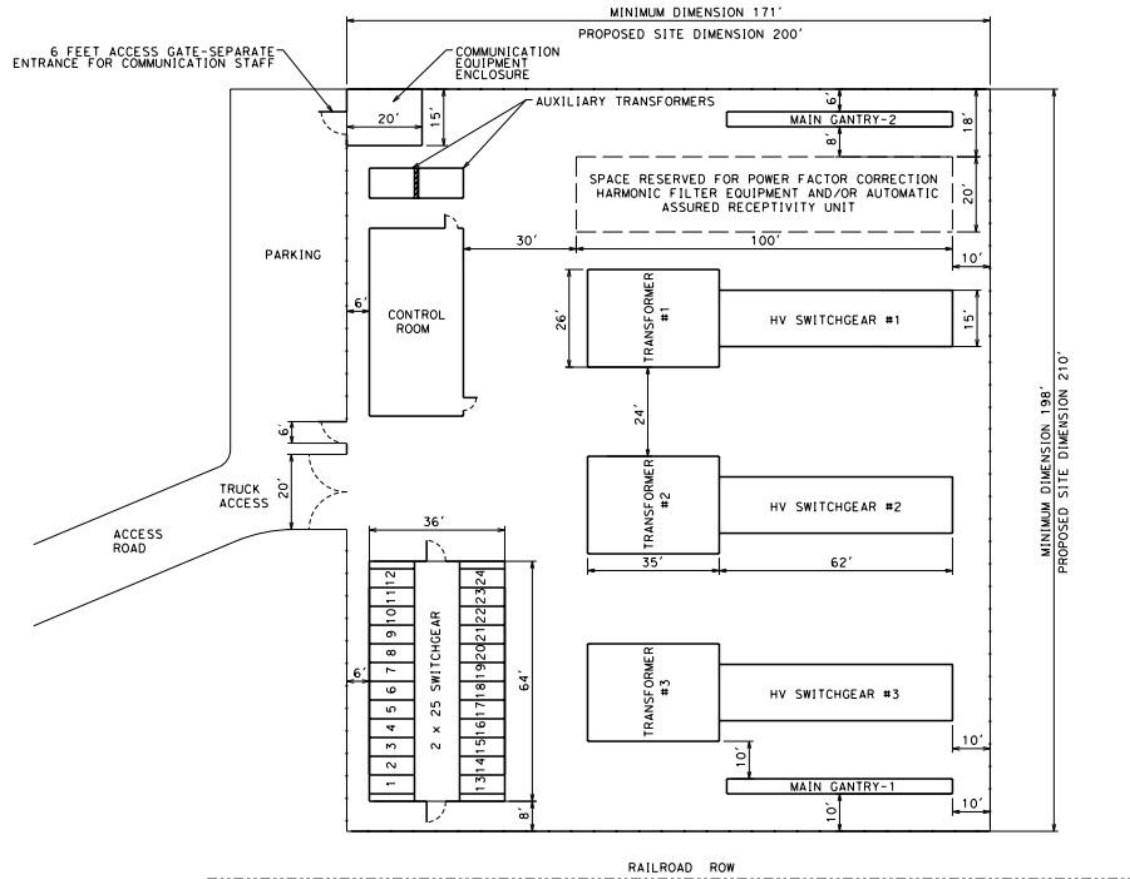

CONCEPTUAL LAYOUT TRACTION POWER SUBSTATION WITH 3 HIGH VOLTAGE TRANSFORMERS -- FIGURE 2

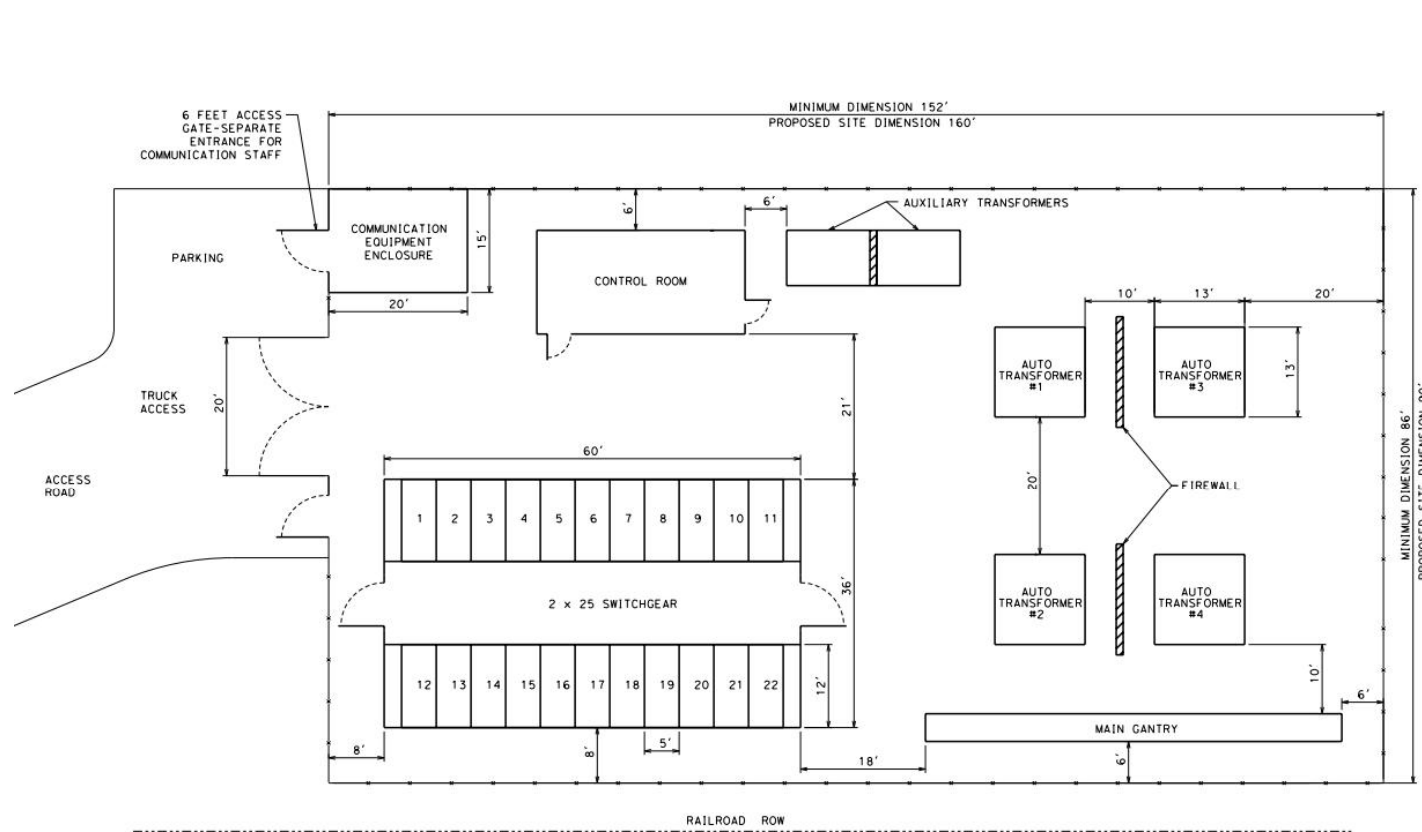

NOTES:

1. THIS IS A TYPICAL LAYOUT AND THE ORIENTATION OF THE STATION WITH RESPECT TO TRACK, LOCATION OF UTILITY SUPPLY CIRCUITS, EQUIPMENT, AND ROAD ACCESS TO BE DETERMINED ON A SITE-BY-SITE BASIS.
2. THE MAIN GANTRY POSITION SHALL BE PARALLEL TO AND ADJACENT TO THE TRACK.
3. THERE WILL BE A STRAIN GANTRY LOCATED WITHIN THE RAILROAD RIGHT-OF-WAY (ROW), PARALLEL TO AND ON THE OPPOSITE SIDE OF THE TRACK WITH FOOTPRINTS EXACTLY EQUAL TO THAT OF THE MAIN GANTRY.
4. IF THE TRACTION POWER FACILITY (TPF) IS LOCATED AWAY FROM THE TRACK, THE MAIN GANTRY WILL BE LOCATED WITHIN THE RAILROAD ROW, PARALLEL TO AND TOWARDS TPF SIDE OF THE TRACK. IN THIS CASE AN ADDITIONAL 40' WIDE STRIP OF LAND WILL BE REQUIRED FROM THE TPF TO THE RAILROAD ROW FOR LAYING UNDERGROUND DUCT BANKS AND MANHOLES.
5. FOR DUCT BANK AND MANHOLE DETAILS, SEE DWG. TM 3.1.1.3-E AND TM 3.1.1.3-F.
6. THE COMMUNICATION EQUIPMENT ROOM SHALL HOUSE COMMUNICATION INTERFACE EQUIPMENT FOR SCADA SYSTEM AND OTHER WAYSIDE COMMUNICATION EQUIPMENT.
7. THE GANTRIES SHALL BE 40 FEET HIGH.

CONCEPTUAL LAYOUT SWITCHING STATION WITH 4 AUTOTRANSFORMERS - FIGURE 3

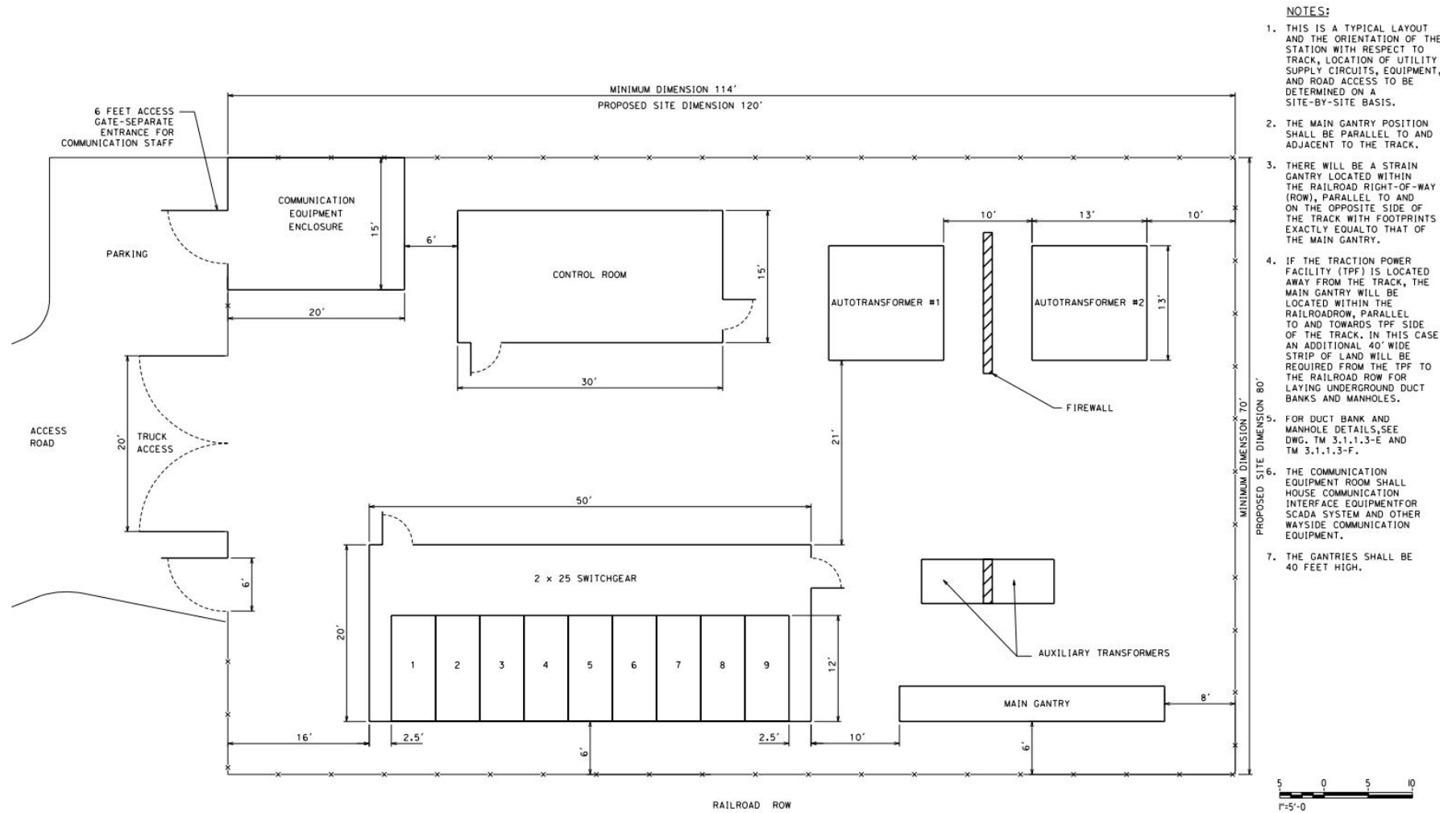

- NOTES:**
1. THIS IS A TYPICAL LAYOUT AND THE ORIENTATION OF THE STATION WITH RESPECT TO TRACK, LOCATION OF UTILITY SUPPLY CIRCUITS, EQUIPMENT, AND ROAD ACCESS TO BE DETERMINED ON A SITE-BY-SITE BASIS.
 2. THE MAIN GANTRY POSITION SHALL BE PARALLEL TO AND ADJACENT TO THE TRACK.
 3. THERE WILL BE A STRAIN GANTRY LOCATED WITHIN THE RAILROAD RIGHT-OF-WAY (ROW), PARALLEL TO AND ON THE OPPOSITE SIDE OF THE TRACK WITH FOOTPRINTS EXACTLY EQUAL TO THAT OF THE MAIN GANTRY.
 4. IF THE TRACTION POWER FACILITY (TPF) IS LOCATED AWAY FROM THE TRACK, THE MAIN GANTRY WILL BE LOCATED WITHIN THE RAILROADROW, PARALLEL TO AND TOWARDS TPF SIDE OF THE TRACK. IN THIS CASE AN ADDITIONAL 40' WIDE STRIP OF LAND WILL BE REQUIRED FROM THE TPF TO THE RAILROAD ROW FOR LAYING UNDERGROUND DUCT BANKS AND MANHOLES.
 5. FOR DUCT BANK AND MANHOLE DETAILS,SEE DWG. TM 3.1.1.3-E AND TM 3.1.1.3-F.
 6. THE COMMUNICATION EQUIPMENT ROOM SHALL HOUSE COMMUNICATION INTERFACE EQUIPMENTFOR SCADA SYSTEM AND OTHER WAYSIDE COMMUNICATION EQUIPMENT.
 7. THE GANTRIES SHALL BE 40 FEET HIGH.

CONCEPTUAL LAYOUT PARALLELING STATION WITH 2 AUTOTRANSFORMERS - FIGURE 4

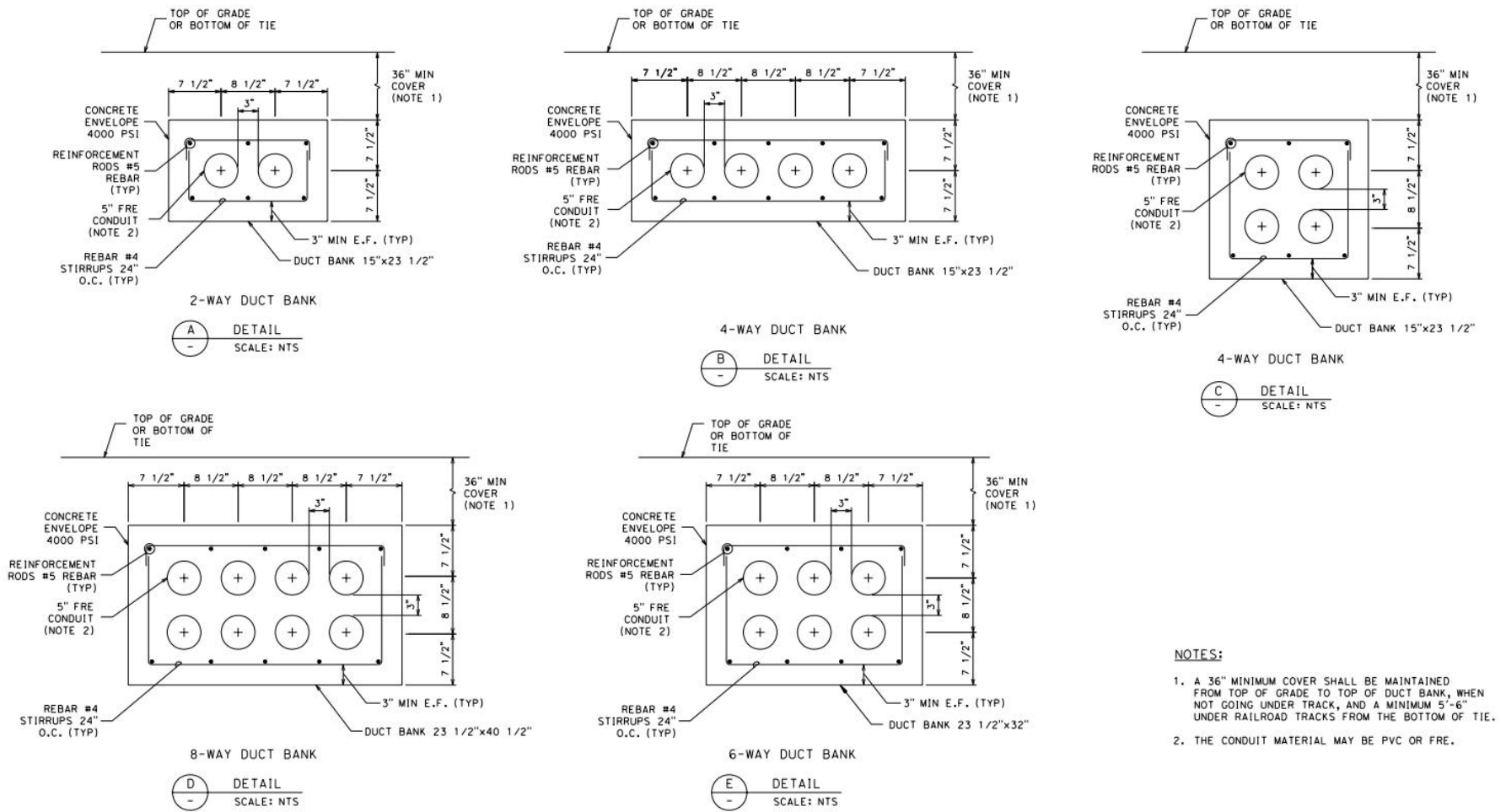

TYPICAL DUCT BANK DETAILS - FIGURE 5

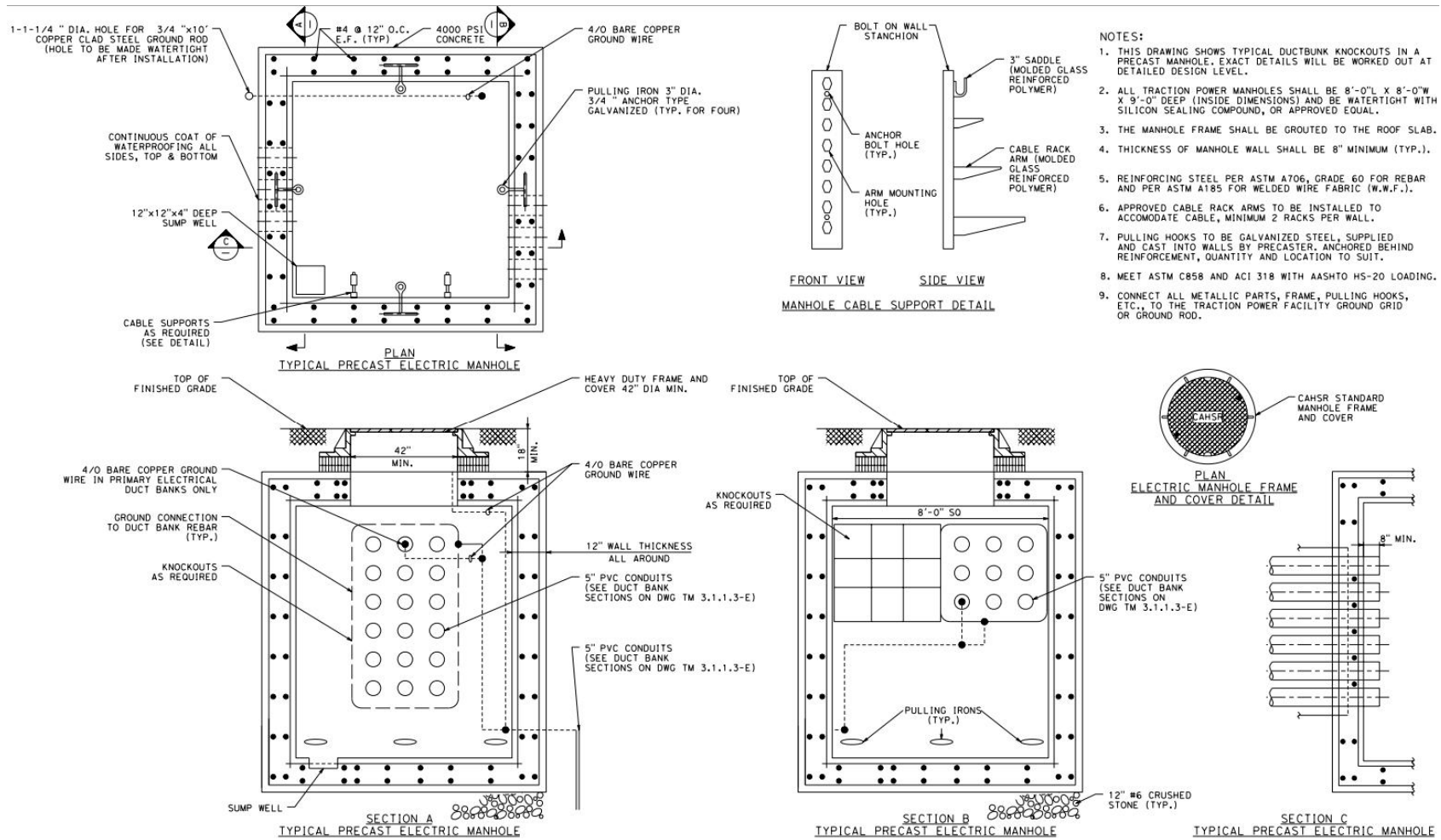

TYPICAL MANHOLE DETAILS - FIGURE 6

NOTES:

1. ALTERNATIVE 1 IS THE PREFERRED OPTION. ALTERNATIVE 2 MAY BE USED IF ADEQUATE LAND IS NOT AVAILABLE ADJACENT TO RAILROAD ROW.
2. THE SPACING OF MANHOLE IS INDICATIVE ONLY. ACTUAL LAYOUT WILL DEPEND UPON THE SITE CONDITIONS.
3. THE WIDTH OF THE STRIP OF LAND REQUIRED FOR LAYING OF DUCT BANKS SHALL BE 40' FOR SUBSTATIONS AND SWITCHING STATIONS, AND 30' FOR PARALLELING STATIONS.
4. THE MAIN GANTRY AND THE STRAIN GANTRY SHALL BE 4' WIDE AND 40' HIGH. SEE DRAWINGS TM 3.1.1.3-A, TM 3.1.1.3-B, TM 3.1.1.3-C AND TM 3.1.1.3-D FOR THE LENGTHS OF THESE GANTRIES.

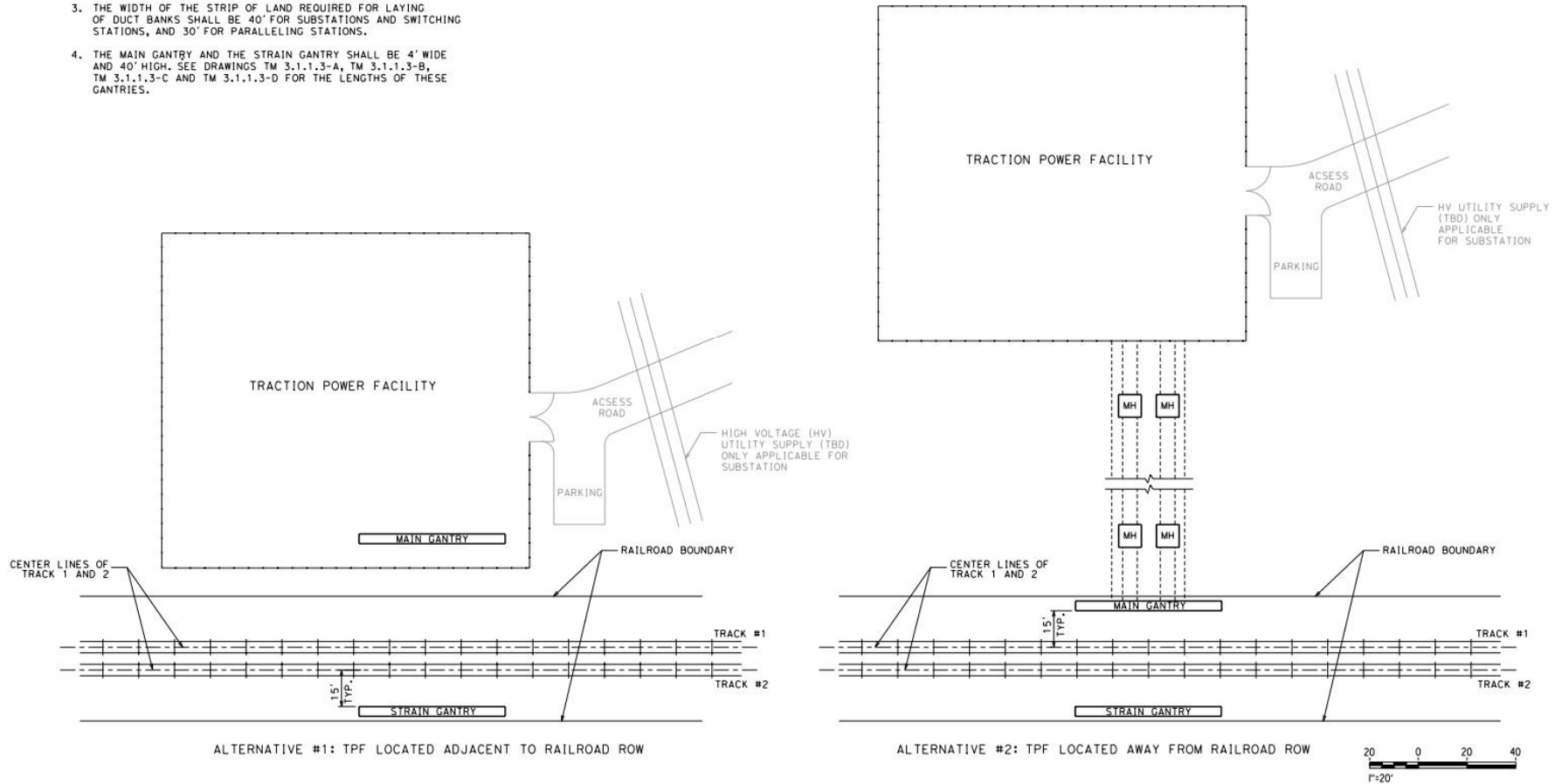

ALTERNATIVE CONCEPTUAL LOCATIONS OF TRACTION POWER FACILITIES RELATIVE TO RAILROAD ROW - FIGURE 7

6 FEET ACCESS GATE-SEPARATE ENTRANCE FOR COMMUNICATION STAFF

MINIMUM DIMENSION 171'
PROPOSED SITE DIMENSION 200'

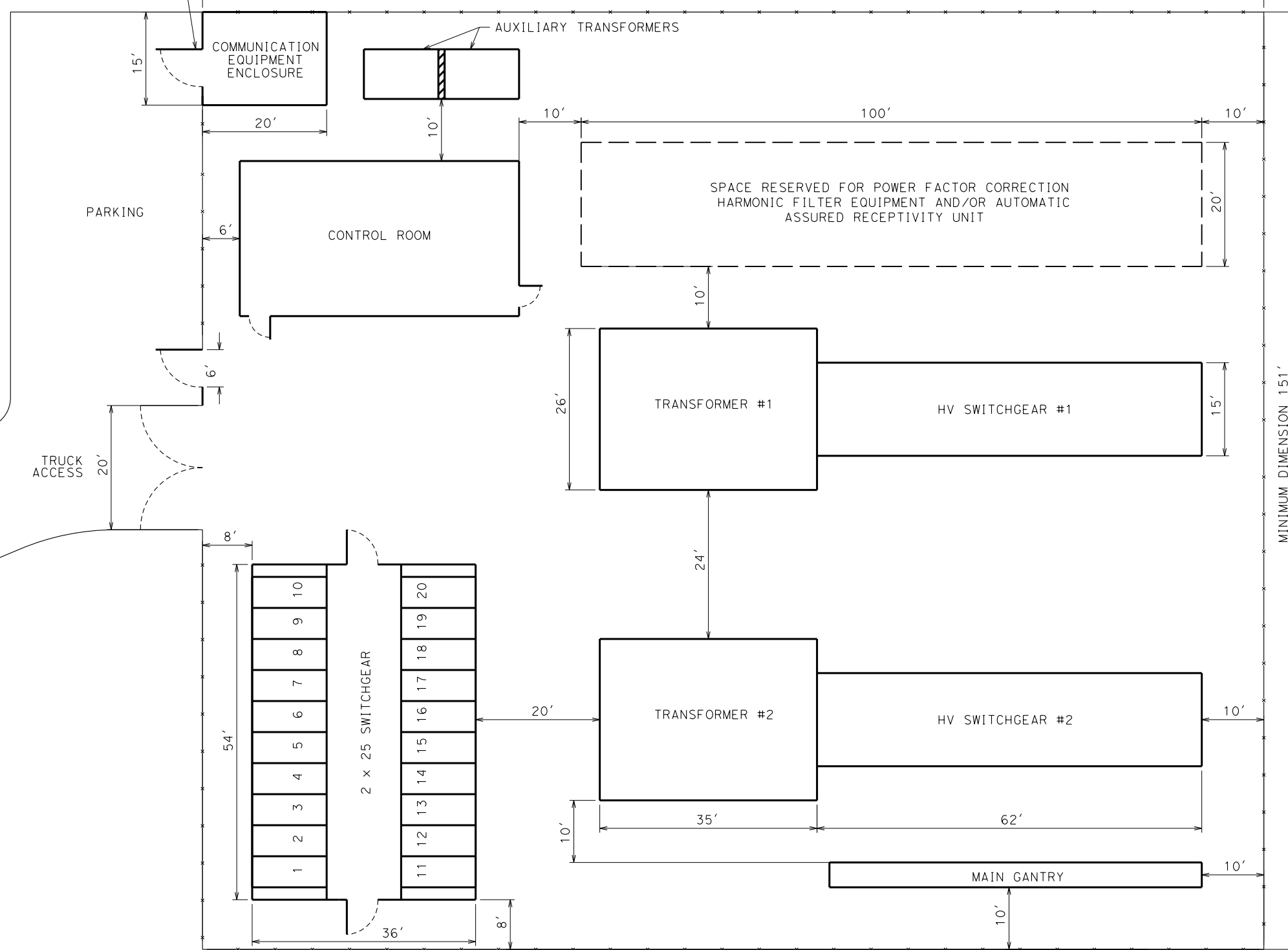

NOTES:

1. THIS IS A TYPICAL LAYOUT AND THE ORIENTATION OF THE STATION WITH RESPECT TO TRACK, LOCATION OF UTILITY SUPPLY CIRCUITS, EQUIPMENT, AND ROAD ACCESS TO BE DETERMINED ON A SITE-BY-SITE BASIS.
2. THE MAIN GANTRY POSITION SHALL BE PARALLEL TO AND ADJACENT TO THE TRACK.
3. THERE WILL BE A STRAIN GANTRY LOCATED WITHIN THE RAILROAD RIGHT-OF-WAY (ROW), PARALLEL TO AND ON THE OPPOSITE SIDE OF THE TRACK WITH FOOTPRINTS EXACTLY EQUAL TO THAT OF THE MAIN GANTRY.
4. IF THE TRACTION POWER FACILITY (TPF) IS LOCATED AWAY FROM THE TRACK, THE MAIN GANTRY WILL BE LOCATED WITHIN THE RAILROAD ROW, PARALLEL TO AND TOWARDS TPF SIDE OF THE TRACK. IN THIS CASE AN ADDITIONAL 40' WIDE STRIP OF LAND WILL BE REQUIRED FROM THE TPF TO THE RAILROAD ROW FOR LAYING UNDERGROUND DUCT BANKS AND MANHOLES.
5. FOR DUCT BANK AND MANHOLE DETAILS, SEE DWG. TM 3.1.1.3-E AND TM 3.1.1.3-F.
6. THE COMMUNICATION EQUIPMENT ROOM SHALL HOUSE COMMUNICATION INTERFACE EQUIPMENT FOR SCADA SYSTEM AND OTHER WAYSIDE COMMUNICATION EQUIPMENT.
7. THE GANTRIES SHALL BE 40 FEET HIGH.

MINIMUM DIMENSION 151'
PROPOSED SITE DIMENSION 160'



5/26/2010 2:09:28 PM T:\13259-CAHSR\CADD\TEMP\AFTER COMMENTS\TM 3.1.1.3-A.dgn

REV	DATE	BY	CHK	APP	DESCRIPTION
B	05/26/10				
A	11/05/09				

DESIGNED BY
V. SIBAL
DRAWN BY
S. BURDEYNIK
CHECKED BY
M. PAZ
IN CHARGE
R. SCHMEDES
DATE
05-26-10



CALIFORNIA HIGH-SPEED TRAIN PROJECT
CONCEPTUAL LAYOUT
TRACTION POWER SUBSTATION
WITH 2 HIGH VOLTAGE TRANSFORMERS

CONTRACT NO.
13259D
DRAWING NO.
TM 3.1.1.3-A
SCALE
1"=10'-0"
SHEET NO.
001 OF 007

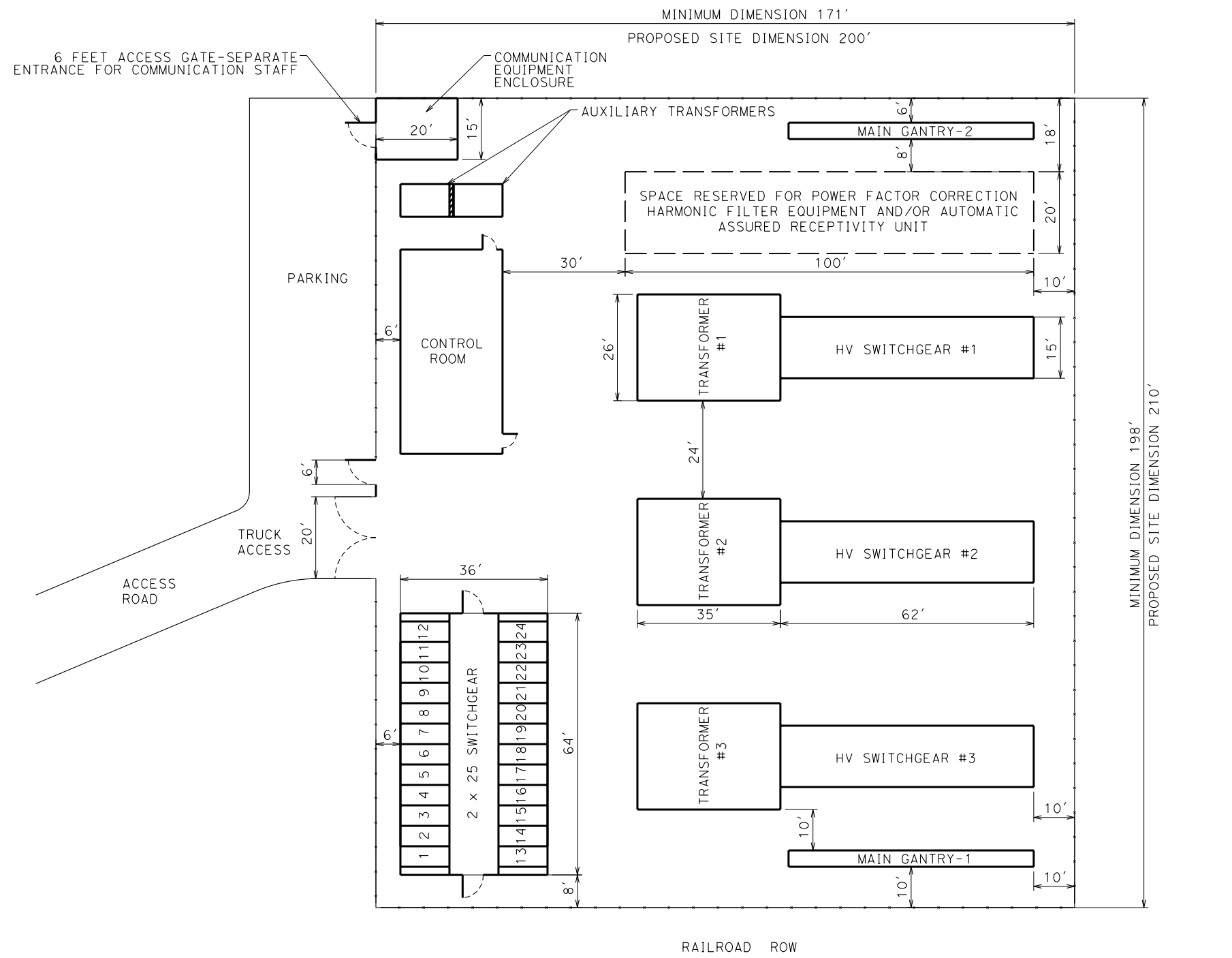

NOTES:

1. THIS IS A TYPICAL LAYOUT AND THE ORIENTATION OF THE STATION WITH RESPECT TO TRACK, LOCATION OF UTILITY SUPPLY CIRCUITS, EQUIPMENT, AND ROAD ACCESS TO BE DETERMINED ON A SITE-BY-SITE BASIS.
2. THERE IS A PROVISION FOR INSTALLING TWO MAIN GANTRIES FOR FACILITATING CONNECTIONS WITH OVERHEAD CONTACT SYSTEM OF DIFFERENT SECTIONS.
3. THERE WILL BE A STRAIN GANTRY LOCATED WITHIN THE RAILROAD RIGHT-OF-WAY (ROW), PARALLEL TO AND ON THE OPPOSITE SIDE OF THE TRACK WITH FOOTPRINTS EXACTLY EQUAL TO THAT OF THE MAIN GANTRY.
4. IF THE TRACTION POWER FACILITY (TPF) IS LOCATED AWAY FROM THE TRACK, THE MAIN GANTRY WILL BE LOCATED WITHIN THE RAILROAD ROW, PARALLEL TO AND TOWARDS TPF SIDE OF THE TRACK. IN THIS CASE AN ADDITIONAL 40' WIDE STRIP OF LAND WILL BE REQUIRED FROM THE TPF TO THE RAILROAD ROW FOR LAYING UNDERGROUND DUCT BANKS AND MANHOLES.
5. FOR DUCT BANK AND MANHOLE DETAILS, SEE DWG. TM 3.1.1.3-E AND TM 3.1.1.3-F.
6. THE COMMUNICATION EQUIPMENT ROOM SHALL HOUSE COMMUNICATION INTERFACE EQUIPMENT FOR SCADA SYSTEM AND OTHER WAYSIDE COMMUNICATION EQUIPMENT.
7. THE GANTRIES SHALL BE 40 FEET HIGH.



5/26/2010 2:09:56 PM T:\13259-CAHSR\CADD\TEMP\AFTER COMMENTS\TM 3.1.1.3-B.dgn

REV	DATE	BY	CHK	APP	DESCRIPTION
B	05/26/10				
A	11/05/09				

DESIGNED BY
V. SIBAL
DRAWN BY
S. BURDEYNIK
CHECKED BY
M. PAZ
IN CHARGE
R. SCHMEDES
DATE
05-26-10



CALIFORNIA HIGH-SPEED TRAIN PROJECT

CONCEPTUAL LAYOUT
TRACTION POWER SUBSTATION
WITH 3 HIGH VOLTAGE TRANSFORMERS

CONTRACT NO.
13259D
DRAWING NO.
TM 3.1.1.3-B
SCALE
1/16"=1'-0"
SHEET NO.
002 OF 007

NOTES:

1. THIS IS A TYPICAL LAYOUT AND THE ORIENTATION OF THE STATION WITH RESPECT TO TRACK, LOCATION OF UTILITY SUPPLY CIRCUITS, EQUIPMENT, AND ROAD ACCESS TO BE DETERMINED ON A SITE-BY-SITE BASIS.
2. THE MAIN GANTRY POSITION SHALL BE PARALLEL TO AND ADJACENT TO THE TRACK.
3. THERE WILL BE A STRAIN GANTRY LOCATED WITHIN THE RAILROAD RIGHT-OF-WAY (ROW), PARALLEL TO AND ON THE OPPOSITE SIDE OF THE TRACK WITH FOOTPRINTS EXACTLY EQUAL TO THAT OF THE MAIN GANTRY.
4. IF THE TRACTION POWER FACILITY (TPF) IS LOCATED AWAY FROM THE TRACK, THE MAIN GANTRY WILL BE LOCATED WITHIN THE RAILROAD ROW, PARALLEL TO AND TOWARDS TPF SIDE OF THE TRACK. IN THIS CASE AN ADDITIONAL 40' WIDE STRIP OF LAND WILL BE REQUIRED FROM THE TPF TO THE RAILROAD ROW FOR LAYING UNDERGROUND DUCT BANKS AND MANHOLES.
5. FOR DUCT BANK AND MANHOLE DETAILS, SEE DWG. TM 3.1.1.3-E AND TM 3.1.1.3-F.
6. THE COMMUNICATION EQUIPMENT ROOM SHALL HOUSE COMMUNICATION INTERFACE EQUIPMENT FOR SCADA SYSTEM AND OTHER WAYSIDE COMMUNICATION EQUIPMENT.
7. THE GANTRIES SHALL BE 40 FEET HIGH.

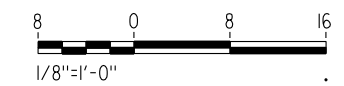
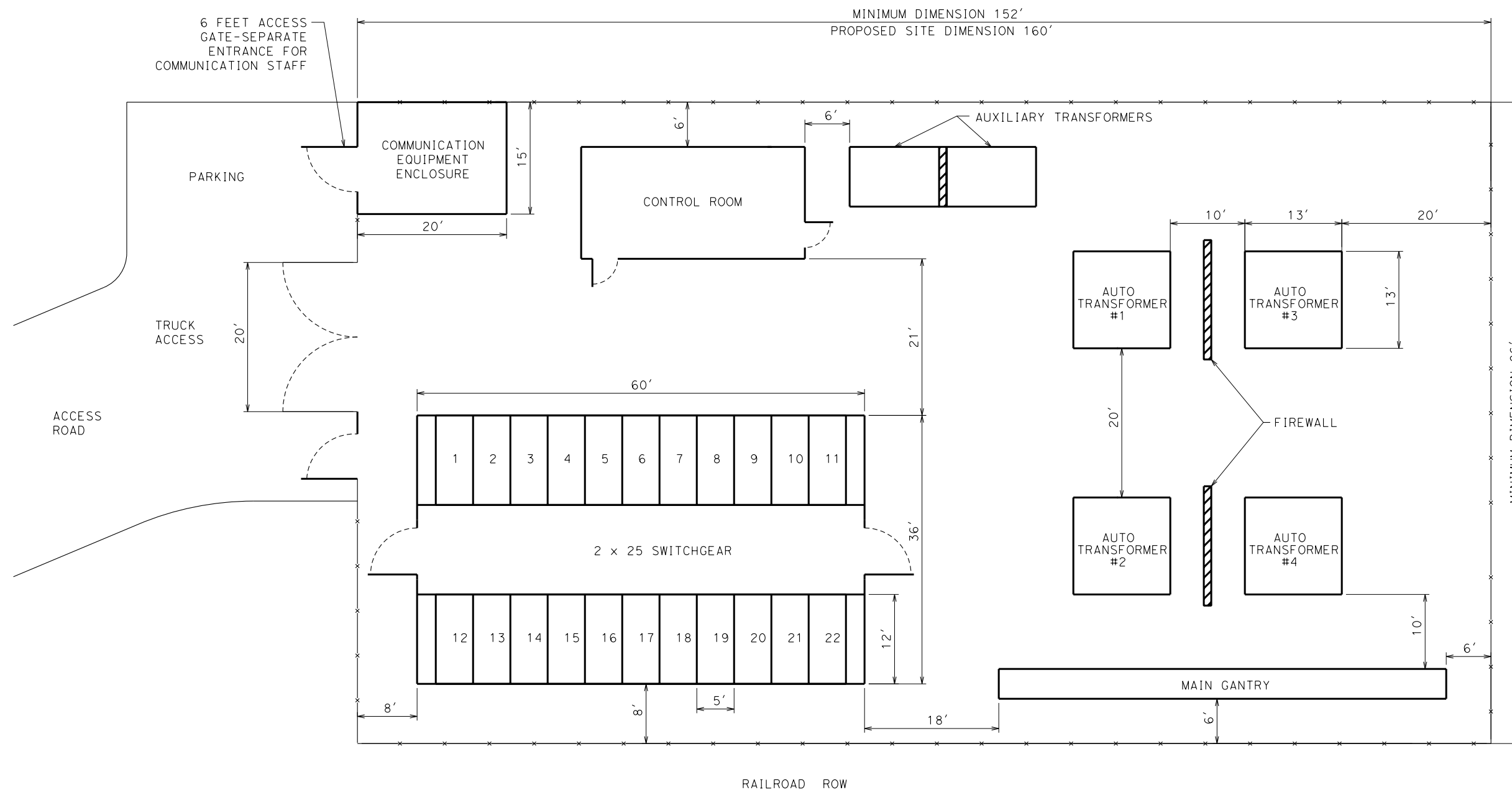

5/26/2010 2:10:28 PM T:\13259-CAHSR\CADD\TEMP\AFTER COMMENTS\TM 3.1.1.3-C.dgn

REV	DATE	BY	CHK	APP	DESCRIPTION
B	05/26/10				
A	11/05/09				

DESIGNED BY
V. SIBAL
DRAWN BY
S. BURDEYNIK
CHECKED BY
M. PAZ
IN CHARGE
R. SCHMEDES
DATE
05-26-10



CALIFORNIA HIGH-SPEED TRAIN PROJECT
CONCEPTUAL LAYOUT
SWITCHING STATION
WITH 4 AUTOTRANSFORMERS

CONTRACT NO.
13259D
DRAWING NO.
TM 3.1.1.3-C
SCALE
1/8"=1'-0"
SHEET NO.
003 OF 007

NOTES:

1. THIS IS A TYPICAL LAYOUT AND THE ORIENTATION OF THE STATION WITH RESPECT TO TRACK, LOCATION OF UTILITY SUPPLY CIRCUITS, EQUIPMENT, AND ROAD ACCESS TO BE DETERMINED ON A SITE-BY-SITE BASIS.
2. THE MAIN GANTRY POSITION SHALL BE PARALLEL TO AND ADJACENT TO THE TRACK.
3. THERE WILL BE A STRAIN GANTRY LOCATED WITHIN THE RAILROAD RIGHT-OF-WAY (ROW), PARALLEL TO AND ON THE OPPOSITE SIDE OF THE TRACK WITH FOOTPRINTS EXACTLY EQUAL TO THAT OF THE MAIN GANTRY.
4. IF THE TRACTION POWER FACILITY (TPF) IS LOCATED AWAY FROM THE TRACK, THE MAIN GANTRY WILL BE LOCATED WITHIN THE RAILROADROW, PARALLEL TO AND TOWARDS TPF SIDE OF THE TRACK. IN THIS CASE AN ADDITIONAL 40' WIDE STRIP OF LAND WILL BE REQUIRED FROM THE TPF TO THE RAILROAD ROW FOR LAYING UNDERGROUND DUCT BANKS AND MANHOLES.
5. FOR DUCT BANK AND MANHOLE DETAILS, SEE DWG. TM 3.1.1.3-E AND TM 3.1.1.3-F.
6. THE COMMUNICATION EQUIPMENT ROOM SHALL HOUSE COMMUNICATION INTERFACE EQUIPMENT FOR SCADA SYSTEM AND OTHER WAYSIDE COMMUNICATION EQUIPMENT.
7. THE GANTRIES SHALL BE 40 FEET HIGH.

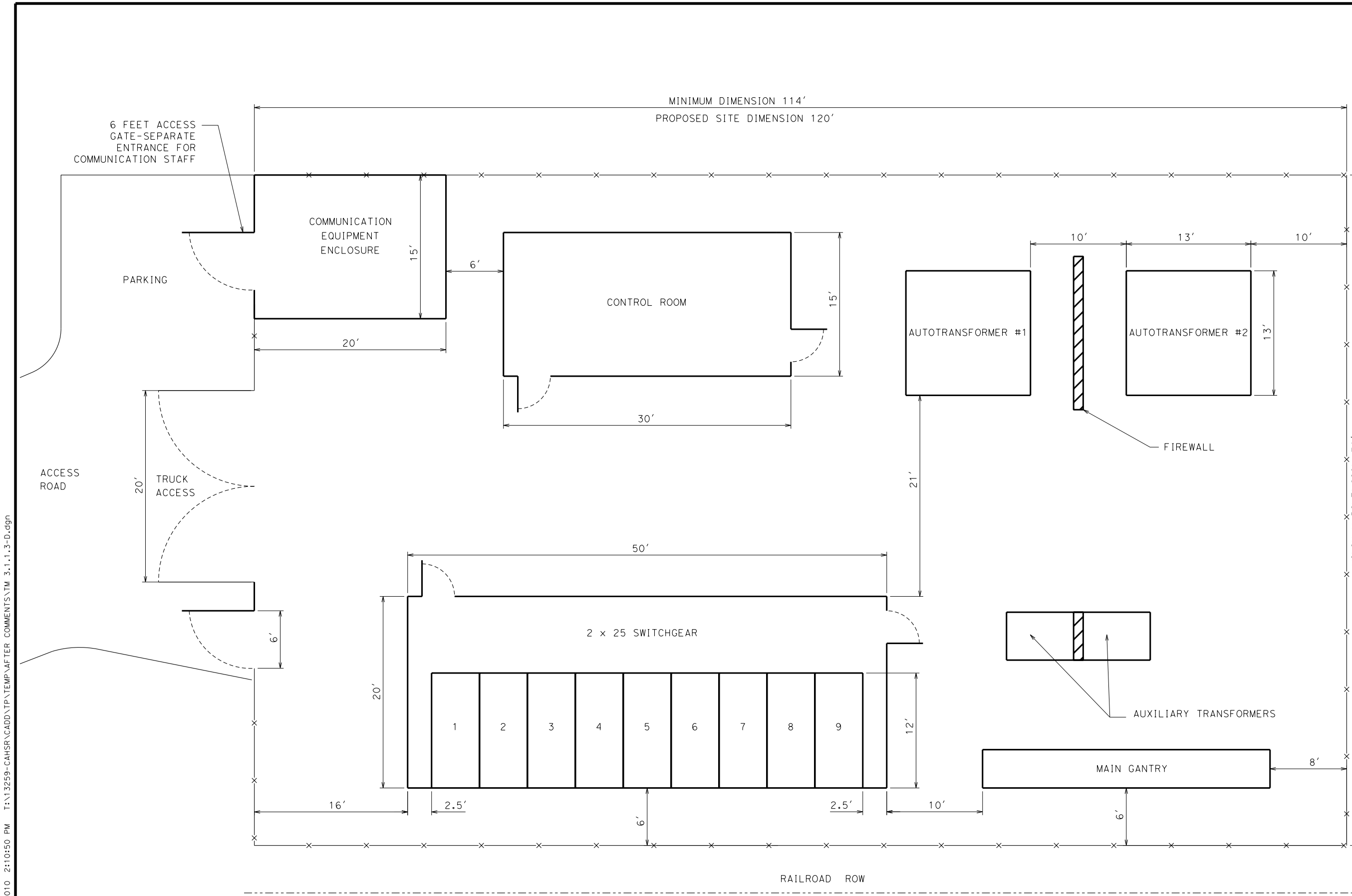

MINIMUM DIMENSION 70'
PROPOSED SITE DIMENSION 80'

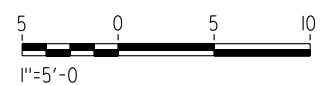

5/26/2010 2:10:50 PM T:\13259-CAHSR\CADD\TEMP\AFTER COMMENTS\TM 3.1.1.3-D.dgn

REV	DATE	BY	CHK	APP	DESCRIPTION
B	05/26/10				
A	11/05/09				

DESIGNED BY
V. SIBAL
DRAWN BY
S. BURDEYNIK
CHECKED BY
M. PAZ
IN CHARGE
R. SCHMEDES
DATE
05-26-10



CALIFORNIA HIGH-SPEED TRAIN PROJECT

CONCEPTUAL LAYOUT
PARALLELING STATION
WITH 2 AUTOTRANSFORMERS

CONTRACT NO.	13259D
DRAWING NO.	TM 3.1.1.3-D
SCALE	1" = 5'-0"
SHEET NO.	004 OF 007

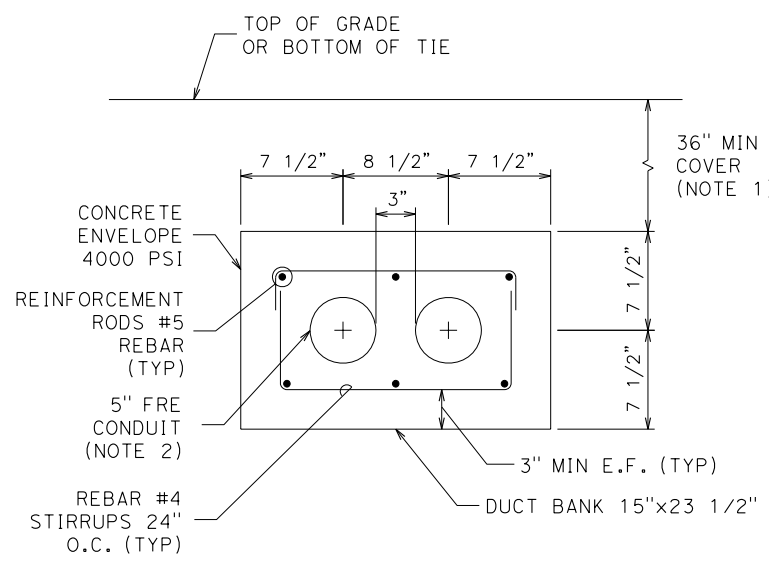

2-WAY DUCT BANK
 A
 -
 DETAIL
 SCALE: NTS

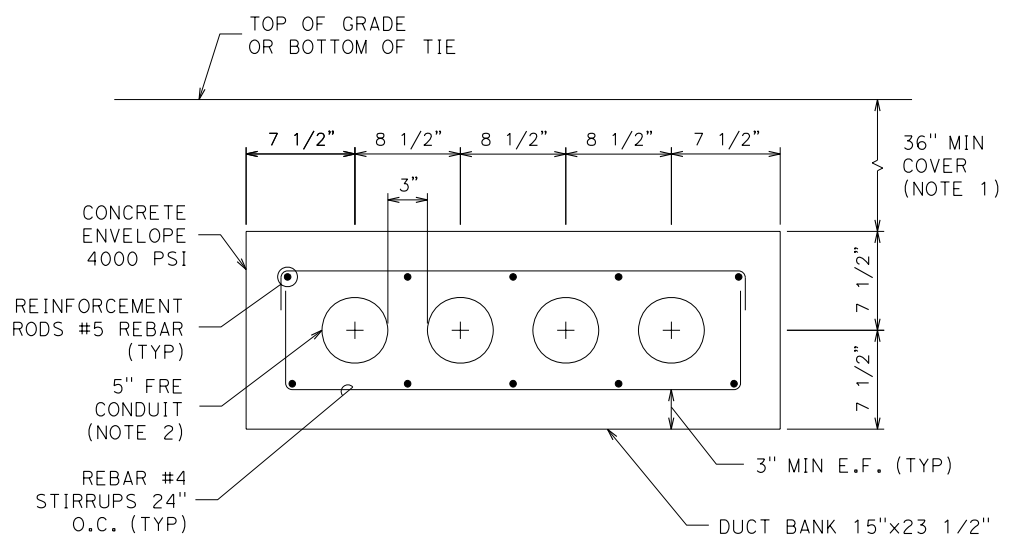

4-WAY DUCT BANK
 B
 -
 DETAIL
 SCALE: NTS

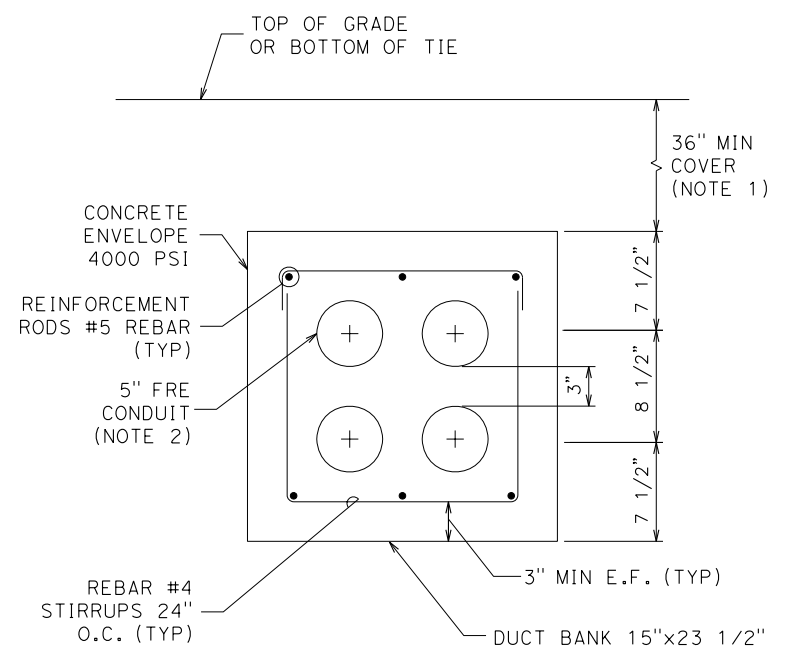

4-WAY DUCT BANK
 C
 -
 DETAIL
 SCALE: NTS

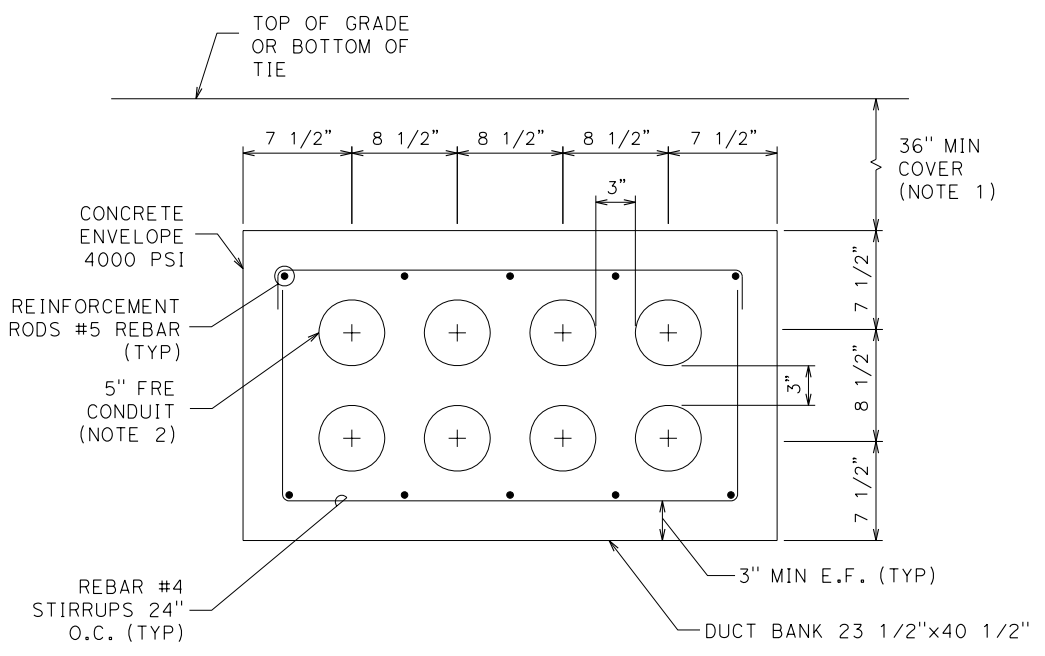

8-WAY DUCT BANK
 D
 -
 DETAIL
 SCALE: NTS

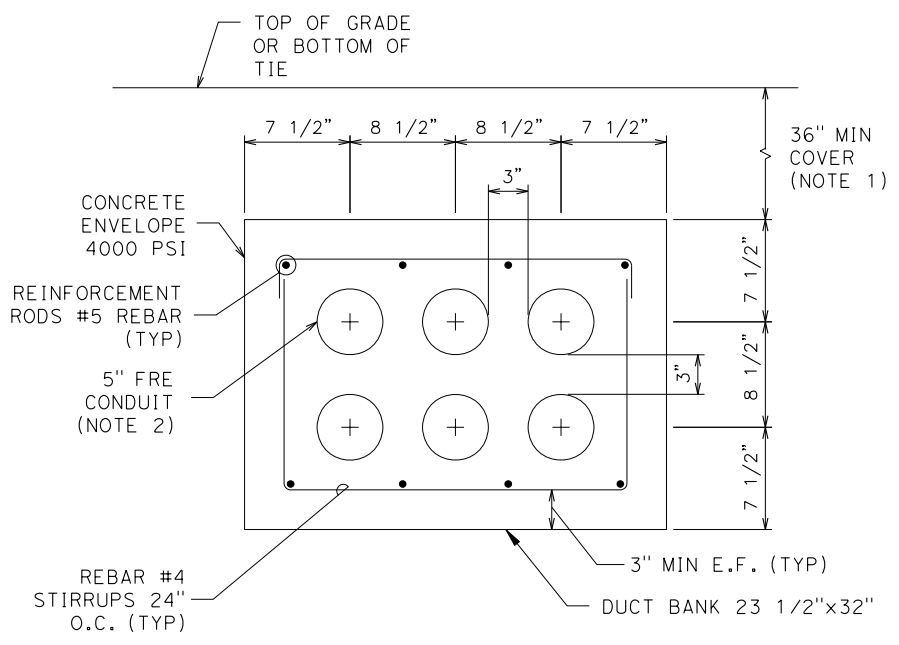

6-WAY DUCT BANK
 E
 -
 DETAIL
 SCALE: NTS

- NOTES:
1. A 36" MINIMUM COVER SHALL BE MAINTAINED FROM TOP OF GRADE TO TOP OF DUCT BANK, WHEN NOT GOING UNDER TRACK, AND A MINIMUM 5'-6" UNDER RAILROAD TRACKS FROM THE BOTTOM OF TIE.
 2. THE CONDUIT MATERIAL MAY BE PVC OR FRE.

5/26/2010 2:11:15 PM T:\13259-CAHSR\CADD\TEMP\AFTER COMMENTS\TM 3.1.1.3-E.dgn

REV	DATE	BY	CHK	APP	DESCRIPTION
B	05/26/10				
A	11/09/09				

DESIGNED BY
V. SIBAL
 DRAWN BY
S. BURDEYNIK
 CHECKED BY
M. PAZ
 IN CHARGE
R. SCHMEDES
 DATE
05-26-10



CALIFORNIA HIGH-SPEED TRAIN PROJECT
 TYPICAL DUCT BANK DETAILS

CONTRACT NO.
13259D
 DRAWING NO.
TM 3.1.1.3-E
 SCALE
NOT TO SCALE
 SHEET NO.
005 OF 007

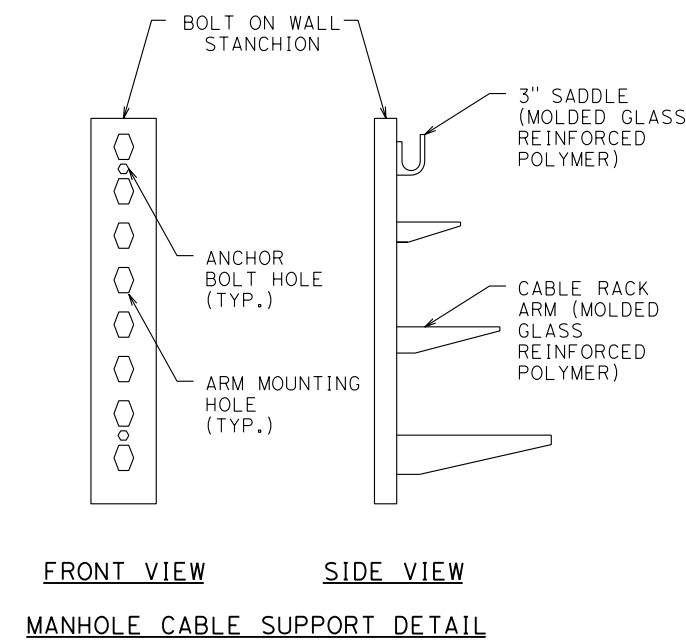
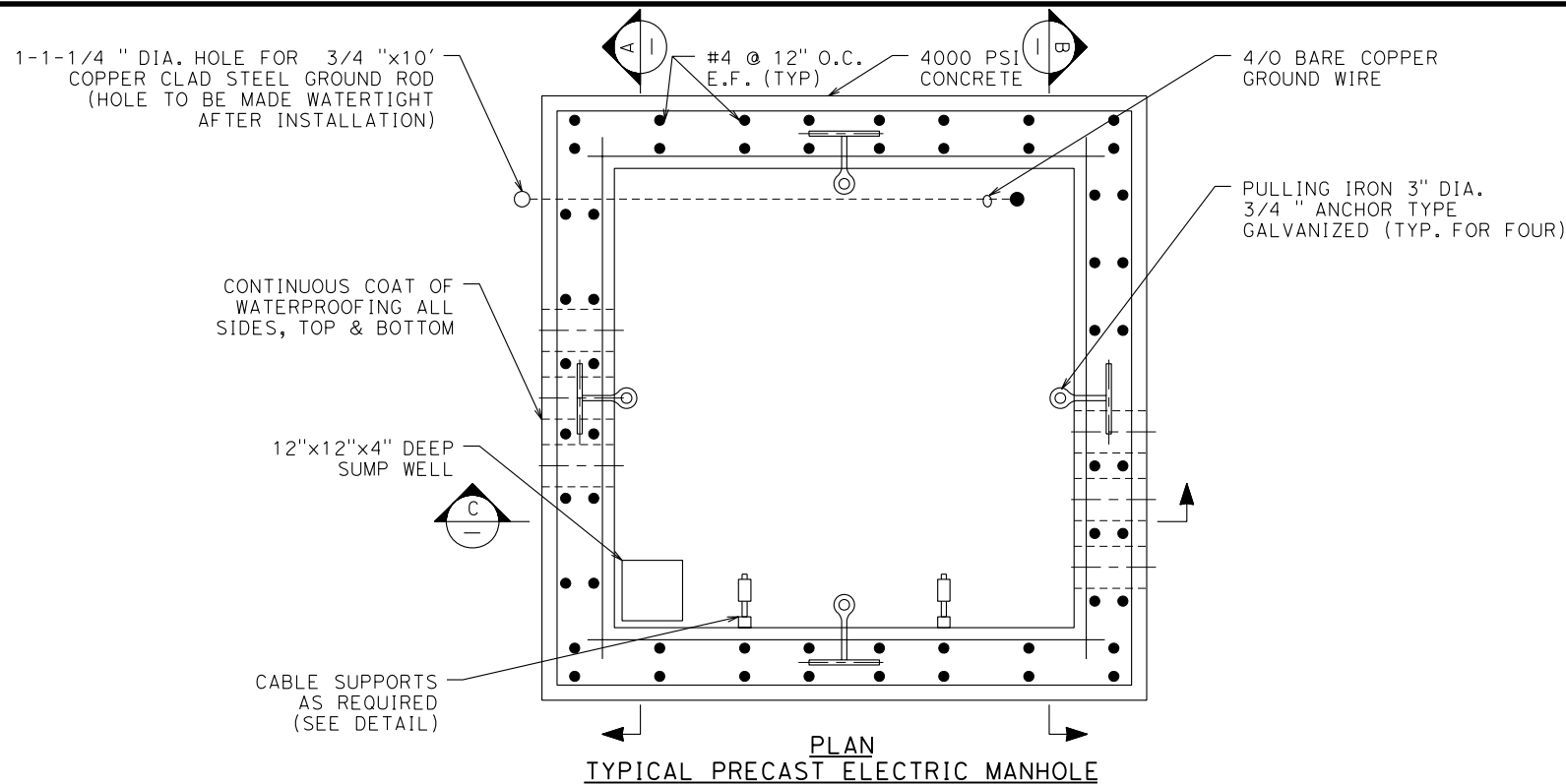

- NOTES:**
1. THIS DRAWING SHOWS TYPICAL DUCTBUNK KNOCKOUTS IN A PRECAST MANHOLE. EXACT DETAILS WILL BE WORKED OUT AT DETAILED DESIGN LEVEL.
 2. ALL TRACTION POWER MANHOLES SHALL BE 8'-0\"/>

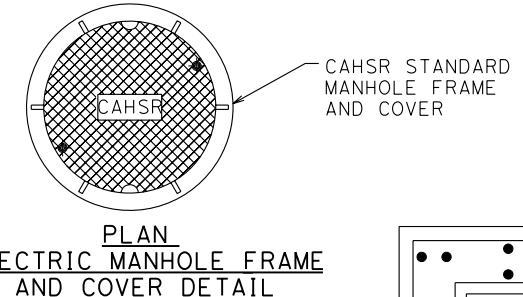
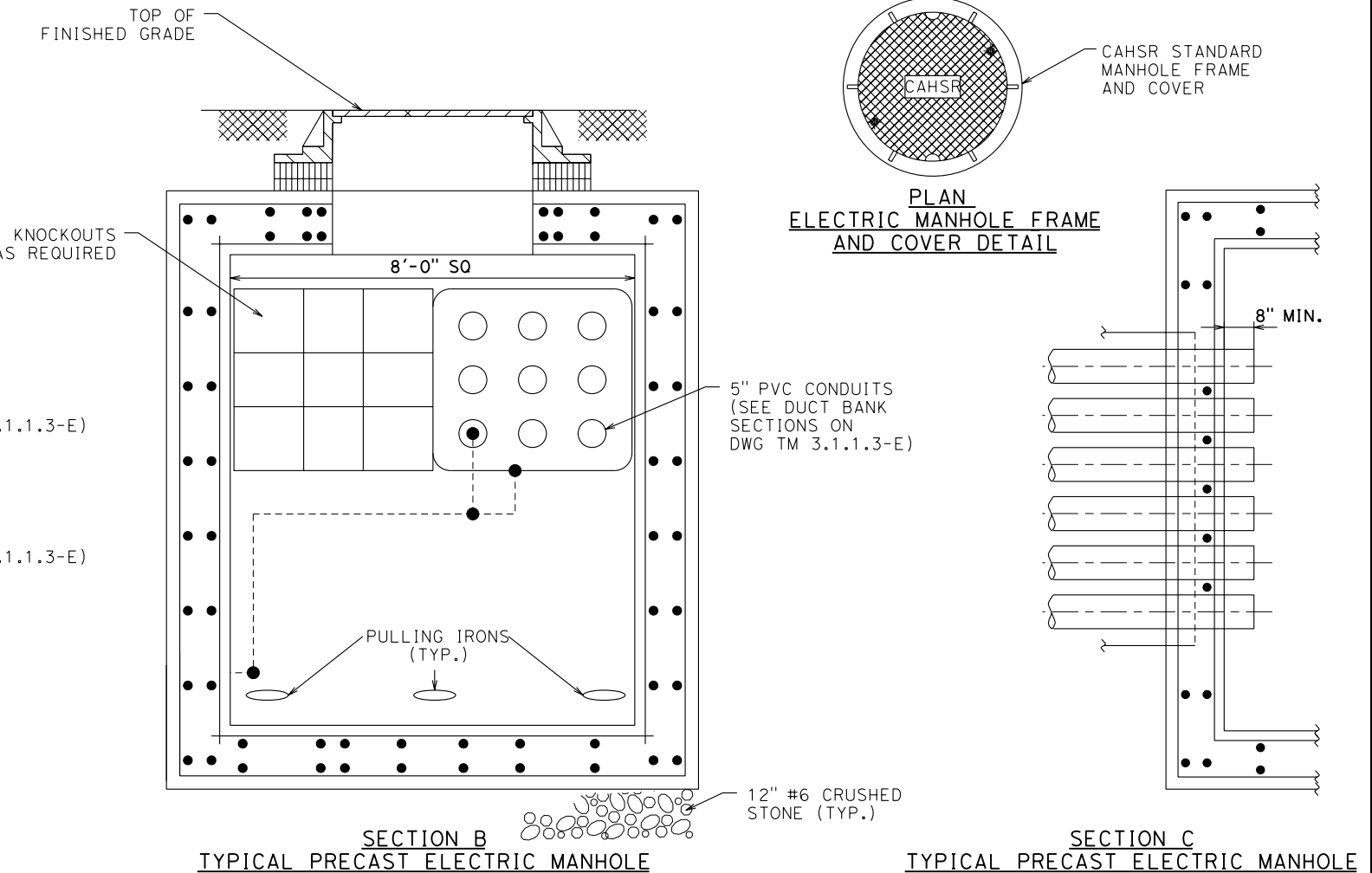
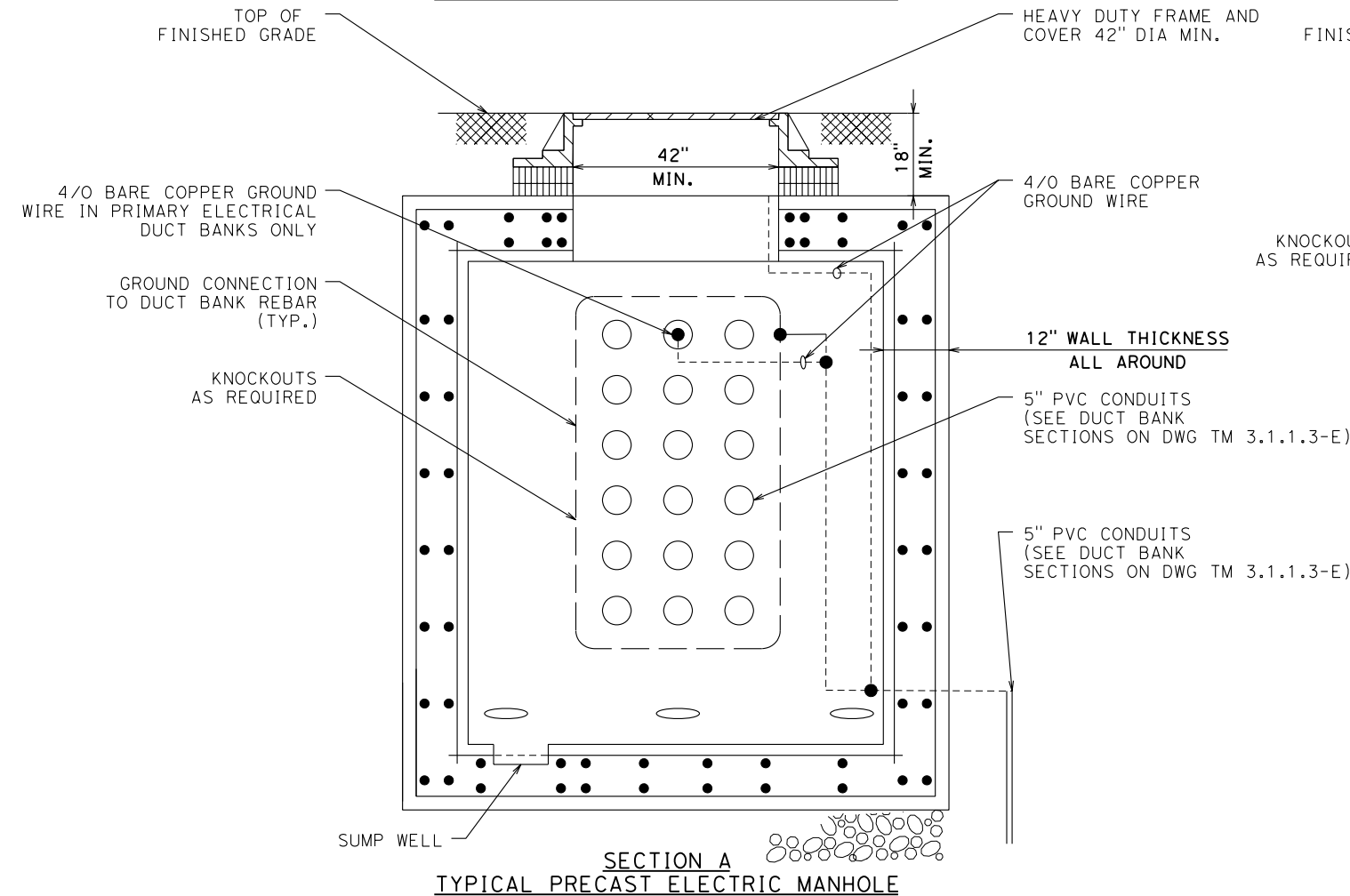

5/26/2010 2:11:35 PM T:\13259-CAHSR\CADD\TEMP\AFTER COMMENTS\TM 3.1.1.3-F.dgn

REV	DATE	BY	CHK	APP	DESCRIPTION
B	05/26/10				
A	11-09-09				

DESIGNED BY
V. SIBAL
DRAWN BY
S. BURDEYNIK
CHECKED BY
M. PAZ
IN CHARGE
R. SCHMEDES
DATE
05-26-10



CALIFORNIA HIGH-SPEED TRAIN PROJECT
TYPICAL MANHOLE DETAILS

CONTRACT NO.
13259D
DRAWING NO.
TM 3.1.1.3-F
SCALE
NTS
SHEET NO.
006 OF 007

NOTES:

1. ALTERNATIVE 1 IS THE PREFERRED OPTION. ALTERNATIVE 2 MAY BE USED IF ADEQUATE LAND IS NOT AVAILABLE ADJACENT TO RAILROAD ROW.
2. THE SPACING OF MANHOLE IS INDICATIVE ONLY. ACTUAL LAYOUT WILL DEPEND UPON THE SITE CONDITIONS.
3. THE WIDTH OF THE STRIP OF LAND REQUIRED FOR LAYING OF DUCT BANKS SHALL BE 40' FOR SUBSTATIONS AND SWITCHING STATIONS, AND 30' FOR PARALLELING STATIONS.
4. THE MAIN GANTRY AND THE STRAIN GANTRY SHALL BE 4' WIDE AND 40' HIGH. SEE DRAWINGS TM 3.1.1.3-A, TM 3.1.1.3-B, TM 3.1.1.3-C AND TM 3.1.1.3-D FOR THE LENGTHS OF THESE GANTRIES.

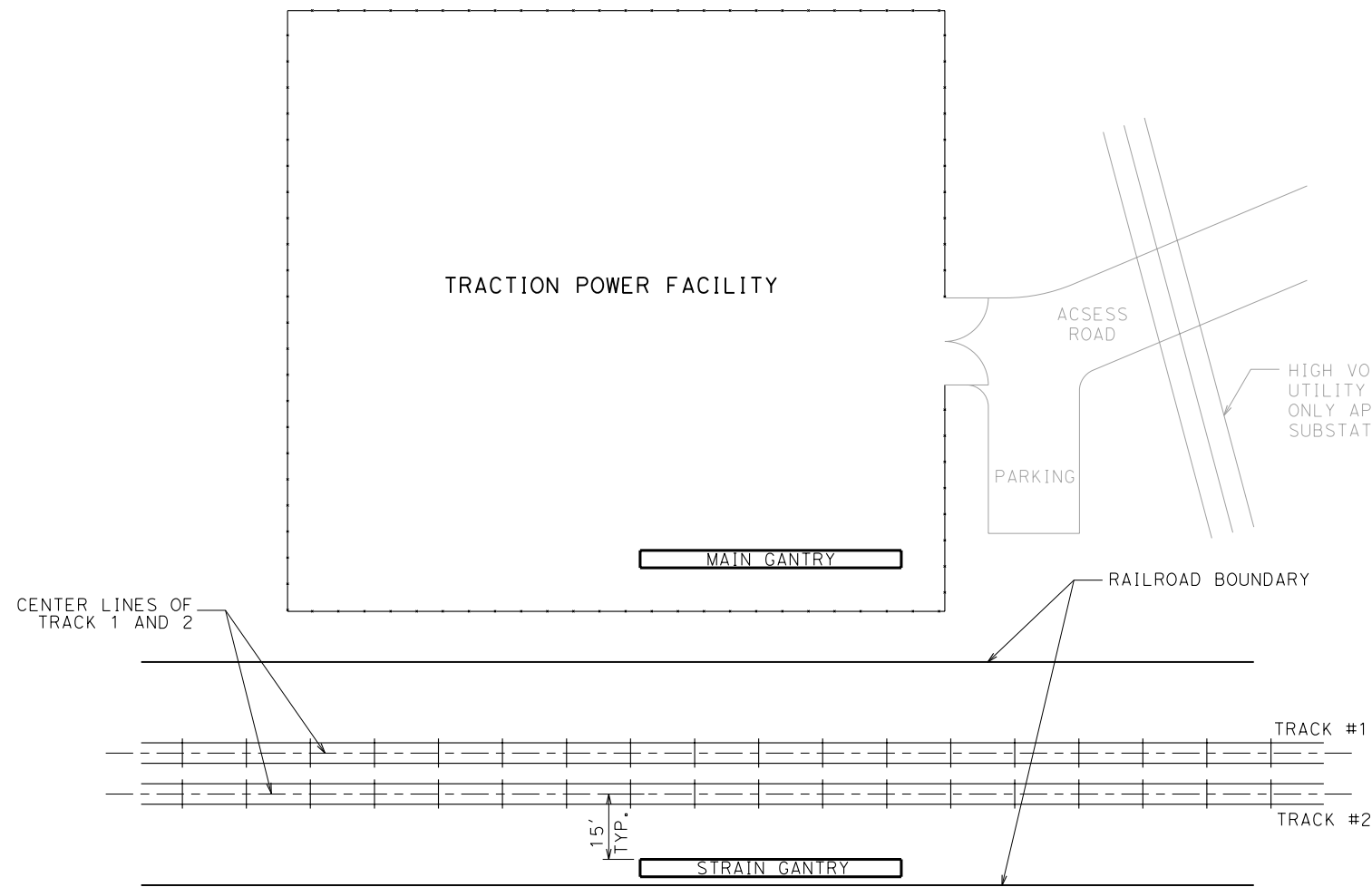

ALTERNATIVE #1: TPF LOCATED ADJACENT TO RAILROAD ROW

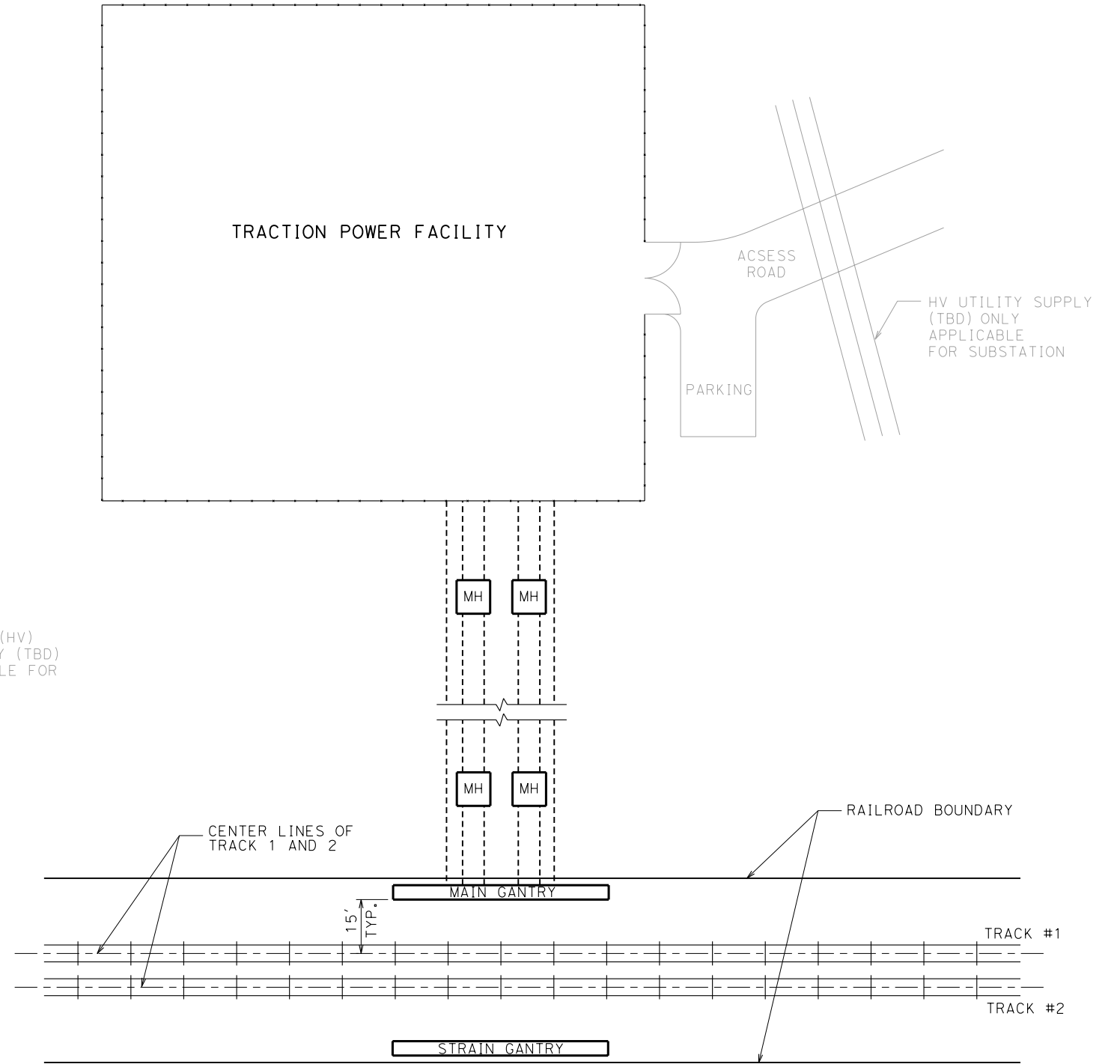

ALTERNATIVE #2: TPF LOCATED AWAY FROM RAILROAD ROW

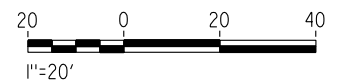

5/26/2010 2:11:59 PM T:\13259-CAHSR\CADD\TEMP\AFTER COMMENTS\TM 3.1.1.3-G.dgn

REV	DATE	BY	CHK	APP	DESCRIPTION
B	05/26/10				
A	11-10-09				

DESIGNED BY V. SIBAL
DRAWN BY S. BURDEYNIK
CHECKED BY M. PAZ
IN CHARGE R. SCHMEDES
DATE 05-26-10



CALIFORNIA HIGH-SPEED TRAIN PROJECT

ALTERNATIVE CONCEPTUAL LOCATIONS OF TRACTION POWER FACILITIES RELATIVE TO RAILROAD ROW

CONTRACT NO. 13259D
DRAWING NO. TM 3.1.1.3-G
SCALE 1"=20'-0"
SHEET NO. 007 OF 007

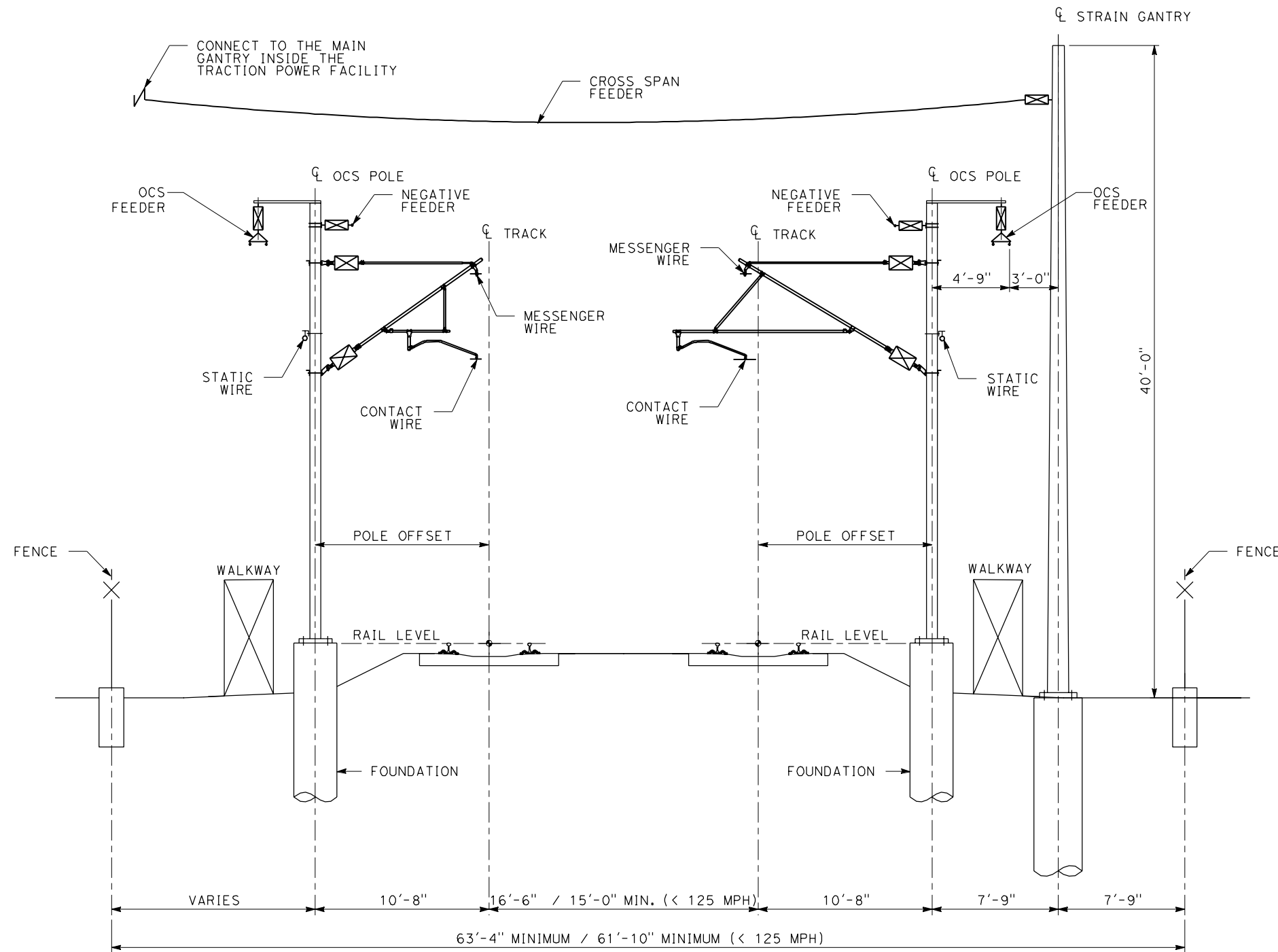

- NOTES:**
1. THIS DRAWING SHOWS CROSS SECTION OF TYPICAL CATENARY FEEDING ARRANGEMENT WITH TRACTION POWER FACILITY LOCATED CLOSE TO THE RAILROAD FENCE, AND CORRESPONDS TO ALTERNATIVE NO. 1 DEPICTED IN DIRECTIVE DRAWING NO. TM 3.1.1.3-G.
 2. THE VERTICAL CLEARANCE BETWEEN THE CROSS SPAN FEEDER AND THE TOP OF THE OCS POLE SHALL BE 5'-0" TYP.

**TYPICAL CATENARY FEEDING GANTRY ARRANGEMENT-
TPF LOCATED CLOSE TO RAILROAD ROW**

10/25/2010 4:31:24 PM T:\13259-CAHSR\CADD\TP\Directive Drawings\TM 3.1.1.3-H.dgn

DESIGNED BY M. PAZ	DRAWN BY S. BURDEYNIK	CHECKED BY V. SIBAL	IN CHARGE R. SCHMEDES	DATE 08/25/10	
ADD:	30% DESIGN				
REV	DATE	BY	CHK	APP	DESCRIPTION
A	08/25/10	XX	XX	XX	ADD: 30% DESIGN

DESIGNED BY
M. PAZ
DRAWN BY
S. BURDEYNIK
CHECKED BY
V. SIBAL
IN CHARGE
R. SCHMEDES
DATE
08/25/10



CALIFORNIA HIGH-SPEED TRAIN PROJECT

TYPICAL CATENARY FEEDING GANTRY ARRANGEMENT-
TPF LOCATED CLOSE TO RAILROAD ROW

CONTRACT NO.	13259
DRAWING NO.	TM 3.1.1.3-H
SCALE	NTS
SHEET NO.	

INSULATOR/DISCONNECT SWITCH ARRANGEMENT

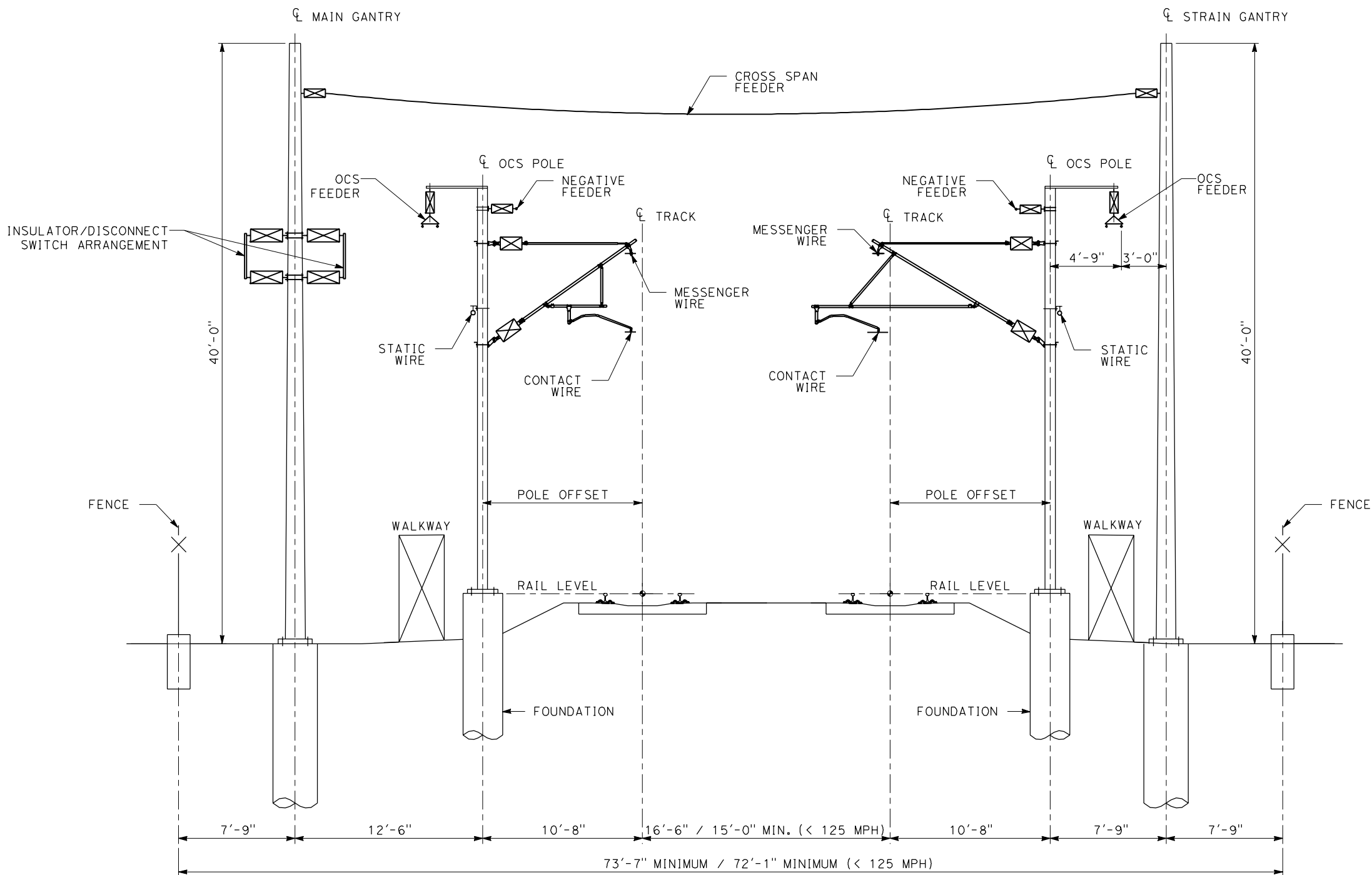

TYPICAL CATENARY FEEDING GANTRY ARRANGEMENT-
TPF LOCATED AWAY FROM RAILROAD ROW

NOTES:

1. THIS DRAWING SHOWS CROSS SECTION OF TYPICAL CATENARY FEEDING ARRANGEMENT WITH TRACTION POWER FACILITY LOCATED AWAY FROM THE RAILROAD FENCE, AND CORRESPONDS TO ALTERNATIVE NO. 2 DEPICTED IN DIRECTIVE DRAWING NO. TM 3.1.1.3-G.
2. THE VERTICAL CLEARANCE BETWEEN THE CROSS SPAN FEEDER AND THE TOP OF THE OCS POLE SHALL BE 5'-0" TYP.

10/25/2010 4:25:16 PM T:\13259-CAHSR\CADD\TP\Directive Drawings\TM 3.1.1.3-1.dgn

DESIGNED BY	M. PAZ
DRAWN BY	S. BURDEYNIK
CHECKED BY	V. SIBAL
IN CHARGE	R. SCHEDES
DATE	08/25/10

REV	DATE	BY	CHK	APP	DESCRIPTION
A	08/25/10	XX	XX	XX	ADD: 30% DESIGN

DESIGNED BY
M. PAZ
DRAWN BY
S. BURDEYNIK
CHECKED BY
V. SIBAL
IN CHARGE
R. SCHEDES
DATE
08/25/10



CALIFORNIA HIGH-SPEED TRAIN PROJECT

TYPICAL CATENARY FEEDING GANTRY ARRANGEMENT-
TPF LOCATED AWAY FROM RAILROAD ROW

CONTRACT NO.	13259
DRAWING NO.	TM 3.1.1.3-1
SCALE	NTS
SHEET NO.	

10/1/2010 10:54:16 AM T:\13259-CAHSR\CADD\TP\Directive Drawings\TM 3.1.1.3-J.dgn

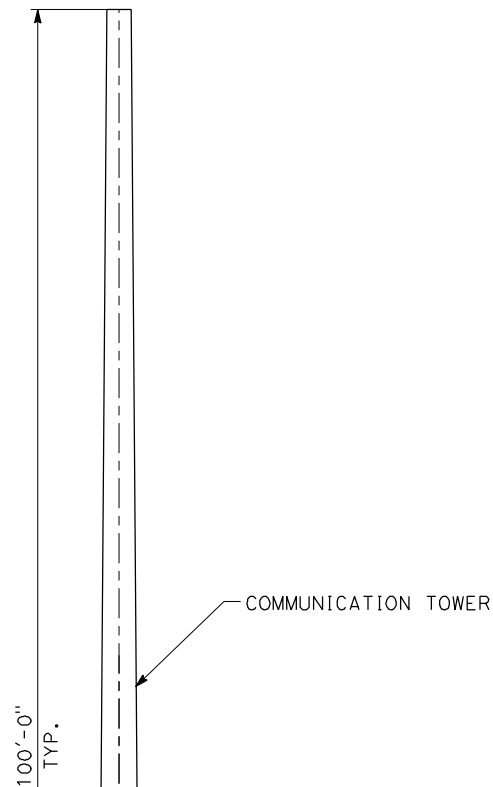

COMMUNICATION TOWER

100'-0"
TYP.

- NOTES:**
1. THIS IS A TYPICAL SECTION OF A TRACTION POWER SUBSTATION DRAWN FOR ILLUSTRATION PURPOSE ONLY.
 2. THE 100' HIGH COMMUNICATION TOWER WILL BE INSTALLED AT EACH TRACTION POWER FACILITY (SUBSTATION, SWITCHING STATION, OR PARALLELING STATION), AND WILL BE THE TALLEST INSTALLATION AT EACH TRACTION POWER FACILITY.
 3. THE HIGH VOLTAGE INTERCONNECTIONS WILL BE REQUIRED ONLY AT TRACTION POWER SUBSTATIONS. UTILITY INTERCONNECTION REQUIREMENTS HAVE NOT BEEN DEFINED. IT COULD BE A CABLE CONNECTION INSTEAD OF OVERHEAD CONNECTION.

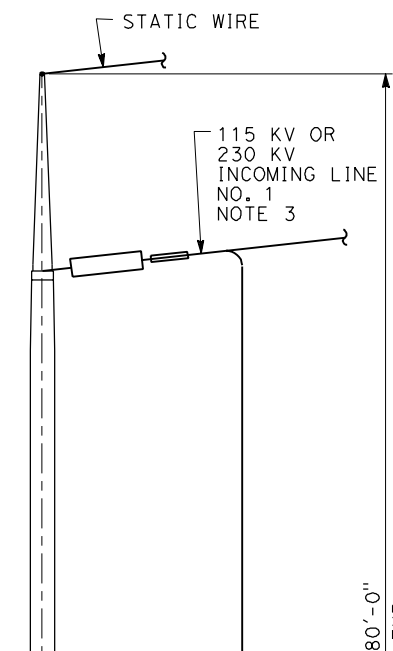

STATIC WIRE

115 KV OR
230 KV
INCOMING LINE
NO. 1
NOTE 3

80'-0"
TYP.

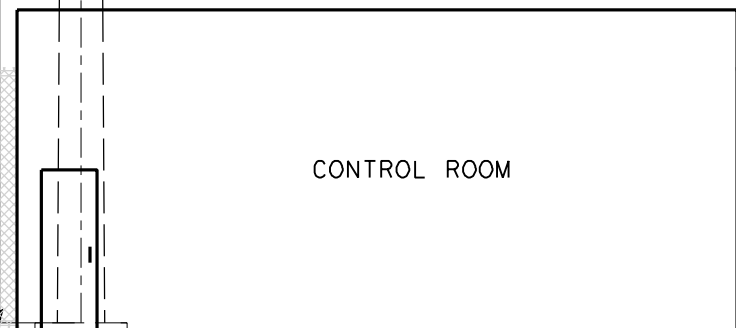

CONTROL ROOM

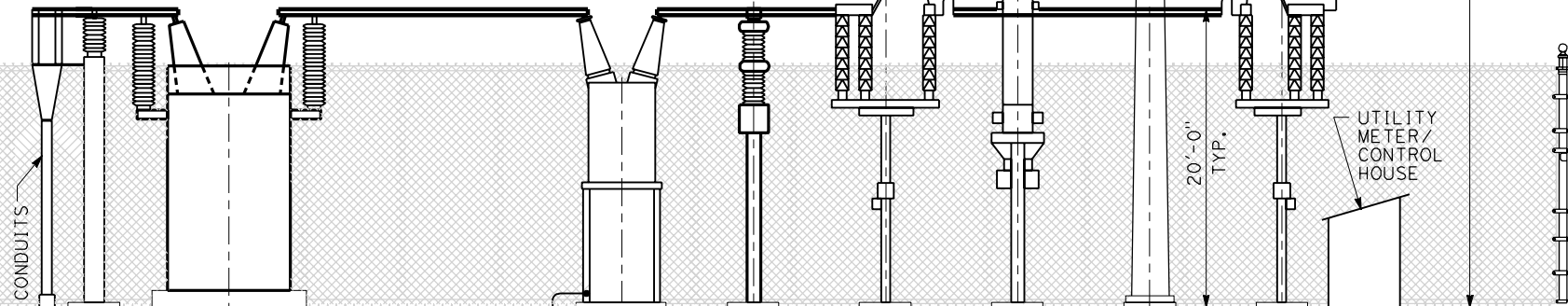

CONDUITS

20'-0"
TYP.

UTILITY
METER/
CONTROL
HOUSE

GROUND LEVEL

TRANSFORMER

CIRCUIT
BREAKER

VT

DISCONNECT
SWITCH

UTILITY
METERING
CT AND VT

DEAD
END
TOWER

UTILITY
DISCONNECT
SWITCH

DESIGNED BY	M. PAZ
DRAWN BY	S. BURDEYNIK
CHECKED BY	V. SIBAL
IN CHARGE	R. SCHMEDES
DATE	09-02-10

REV	DATE	BY	CHK	APP	DESCRIPTION
A	09/02/10	XX	XX	XX	ADD: 30% DESIGN



CALIFORNIA HIGH-SPEED TRAIN PROJECT
TRACTION POWER
 DIRECTIVE DRAWING
 TYPICAL SECTION OF
 A TRACTION POWER FACILITY

CONTRACT NO.	13259
DRAWING NO.	TM 3.1.1.3-J
SCALE	NTS
SHEET NO.	

1/5/2011 3:16:21 PM T:\13259-CAHSR\CADD\TP\Directive Drawings\TM 3.1.1.3-K.dgn

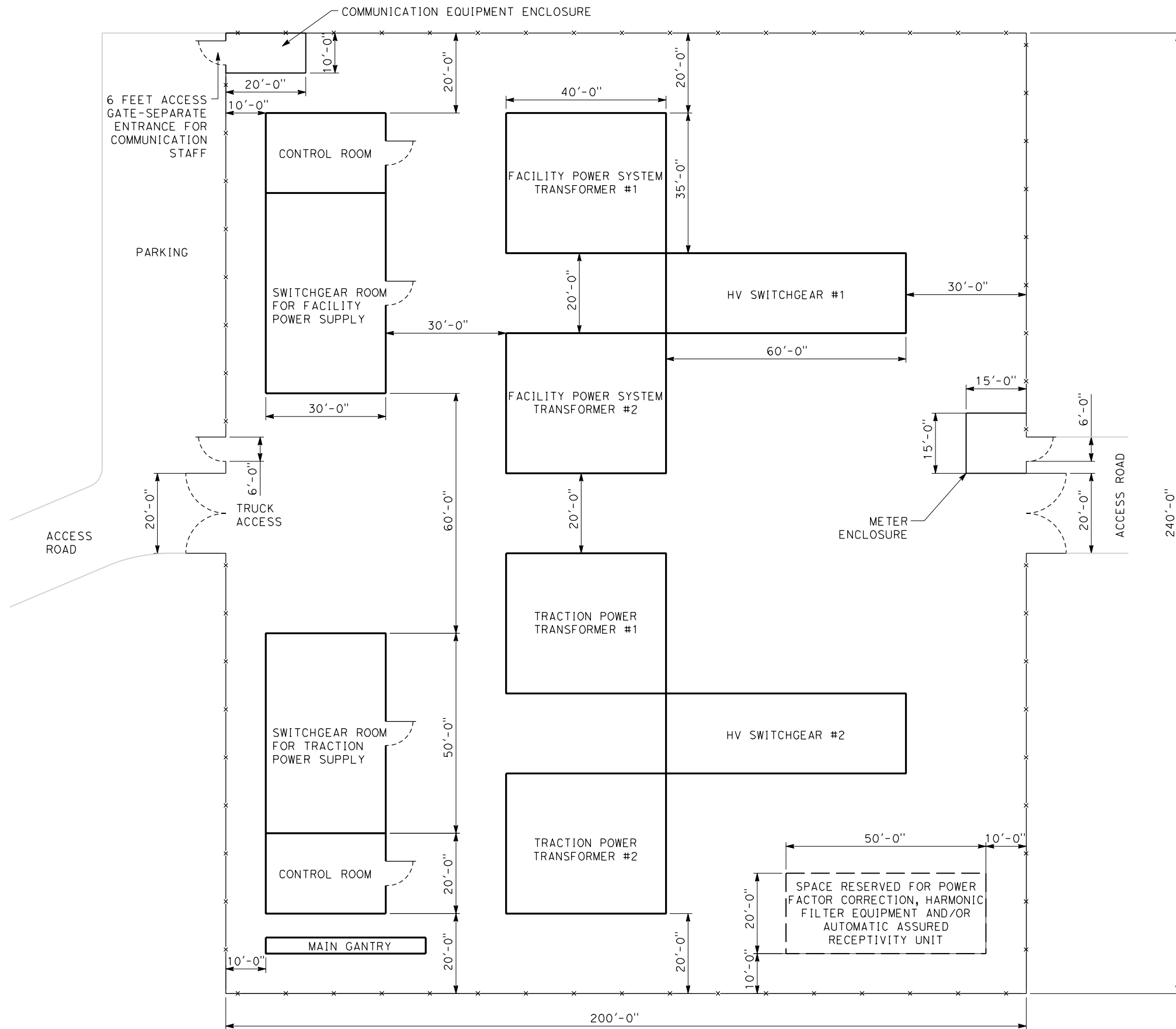

NOTES:

1. THIS IS A TYPICAL CONCEPTUAL LAYOUT OF THE ROLLING STOCK MAINTENANCE FACILITY POWER SUBSTATION. THE LOCATION OF THIS SUBSTATION WITH RESPECT TO TRACK, UTILITY SUPPLY CIRCUITS, EQUIPMENT, AND ROAD ACCESS TO BE DETERMINED ON A SITE-BY-SITE BASIS.
2. HV POWER SHALL BE DRAWN FROM TWO INDEPENDENT SOURCES (AT LEAST FROM TWO SEPARATE HV BUSES).
3. NORMALLY ONE UTILITY SOURCE WILL FEED TRACTION POWER TRANSFORMERS AND THE SECOND WILL FEED FACILITY POWER TRANSFORMERS. THE HV SWITCHGEAR SHALL, HOWEVER, BE CONFIGURED SO THAT EITHER UTILITY SOURCE CAN FEED THE TRANSFORMERS OF THE FACILITY POWER AND/OR TRACTION POWER SYSTEMS.
4. THE TRACTION POWER SUPPLY SYSTEM FOR THE MAINTENANCE FACILITY YARD SHALL BE 1x25 KV AC SYSTEM WITH ONE TRANSFORMER SUPPLYING THE FULL TRACTION POWER LOAD AND THE SECOND ACTING AS STANDBY.
5. AUXILIARY POWER SUPPLY FOR THE SUBSTATION WILL BE PROVIDED BY STEP DOWN TRANSFORMERS CONNECTED TO THE MEDIUM VOLTAGE BUS OF FACILITY POWER SYSTEM (NOT SHOWN ON THE DRAWING).
6. 25 KV TRACTION POWER MAY BE SUPPLIED TO THE OCS THROUGH OVERHEAD FEEDERS VIA THE GANTRY OR THROUGH UNDERGROUND FEEDERS. IF POWER IS SUPPLIED THROUGH OVERHEAD FEEDERS THEN A STRAIN GANTRY SHALL BE PROVIDED WITHIN THE MAINTENANCE FACILITY YARD, PARALLEL TO AND ON THE OPPOSITE SIDE OF TRACK WITH FOOTPRINTS EXACTLY EQUAL TO THAT OF MAIN GANTRY.
7. THE GANTRY SHALL BE 40 FEET HIGH.

REV	DATE	BY	CHK	APP	DESCRIPTION

DESIGNED BY
V. SIBAL
DRAWN BY
S. BURDEYNIK
CHECKED BY
M. PAZ
IN CHARGE
R. SCHMEDES
DATE
10-11-10



CALIFORNIA HIGH-SPEED TRAIN PROJECT

CONCEPTUAL LAYOUT-ROLLING STOCK
MAINTENANCE FACILITY POWER SUBSTATION

CONTRACT NO.
13259
DRAWING NO.
TM 3.1.1.3-K
SCALE
NTS
SHEET NO.

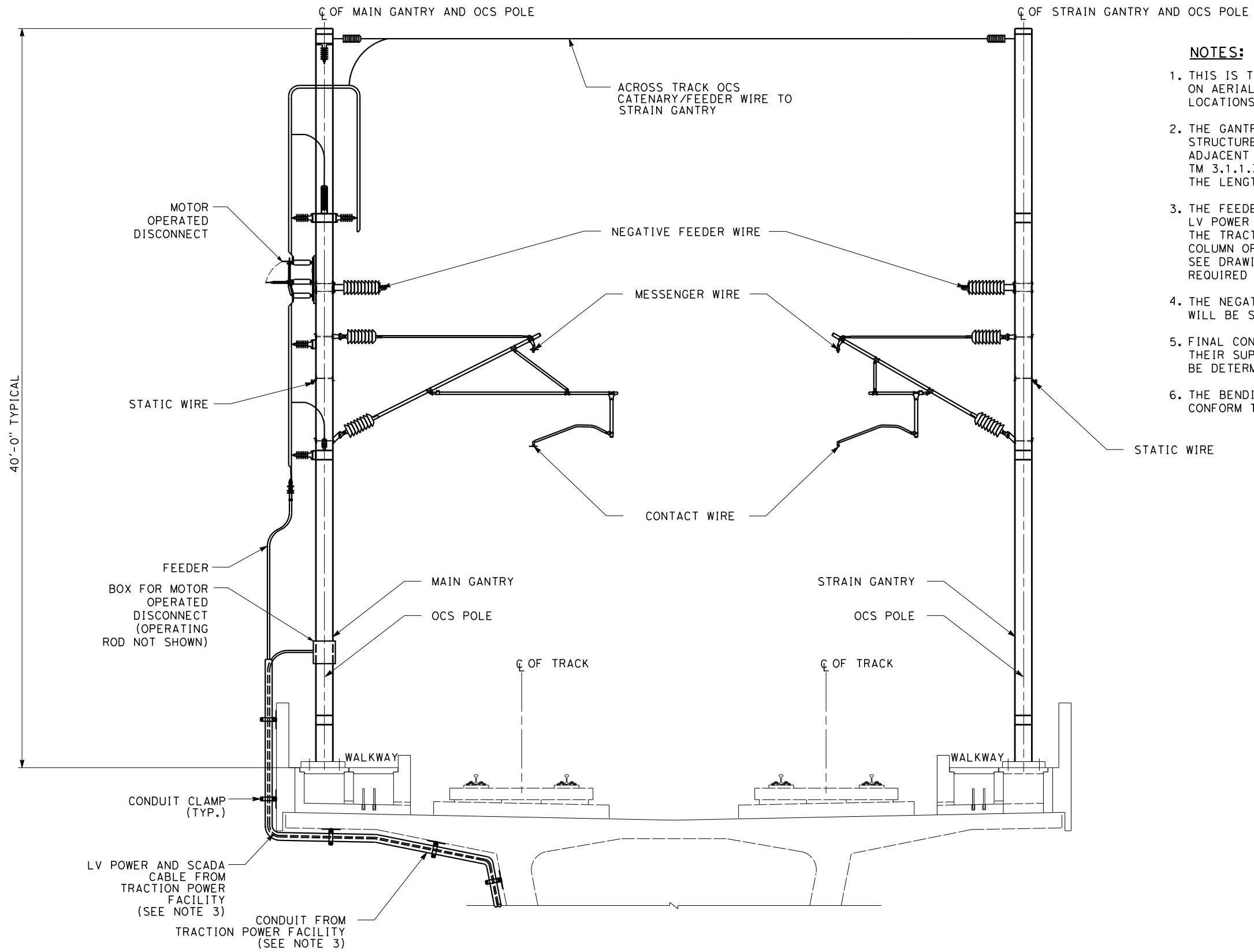

- NOTES:**
1. THIS IS TYPICAL GANTRY FEEDING ARRANGEMENT ON AERIAL STRUCTURES AT TRACTION POWER FACILITY LOCATIONS SPACED GENERALLY FIVE MILES APART.
 2. THE GANTRIES WILL BE LOCATED ON THE AERIAL STRUCTURES ALONG THE ALIGNMENT AND IN BETWEEN ADJACENT OCS POLES. SEE DRAWINGS TM 3.1.1.3-A, TM 3.1.1.3-B, TM 3.1.1.3-C AND TM 3.1.1.3-D FOR THE LENGTHS OF THE GANTRIES.
 3. THE FEEDERS FOR OCS AND NEGATIVE FEEDERS, AND LV POWER AND SCADA CABLES WILL BE ROUTED FROM THE TRACTION POWER FACILITY TO THE BASE OF THE COLUMN OF THE VIADUCT IN DUCT BANK(S). SEE DRAWING TM 3.1.1.3-G FOR THE STRIP OF LAND REQUIRED FOR LAYING OF DUCT BANKS.
 4. THE NEGATIVE FEEDER WIRES AND THE STATIC WIRES WILL BE SUPPORTED AT BOTH THE GANTRIES.
 5. FINAL CONFIGURATION AND ARRANGEMENT OF THE CONDUITS, THEIR SUPPORTS, CONDUIT CLAMPS AND OTHER ITEMS SHALL BE DETERMINED BY THE FINAL DESIGNER.
 6. THE BENDING RADII OF THE CONDUITS/CABLES SHALL CONFORM TO THE RELEVANT CODE.

4/19/2011 3:49:11 PM T:\13259-CAHSR\CADD\TP\Directive Drawings\TM 3.1.1.3-L.dgn burdeynik

REV	DATE	BY	CHK	APP	DESCRIPTION

DESIGNED BY
V. SIBAL
DRAWN BY
S. BURDEYNIK
CHECKED BY
M. PAZ
IN CHARGE
R. SCHMEDES
DATE
04-19-11



CALIFORNIA HIGH-SPEED TRAIN PROJECT

TYPICAL CATENARY FEEDING GANTRY ARRANGEMENT
ON AERIAL STRUCTURES AT
TRACTION POWER FACILITY LOCATIONS

CONTRACT NO.
13259
DRAWING NO.
TM 3.1.1.3-L
SCALE
NTS
SHEET NO.

4/20/2011 1:12:27 PM T:\13259-CAHSR\CADD\TP\Directive Drawings\TM 3.1.1.3-M.dgn burdeynik

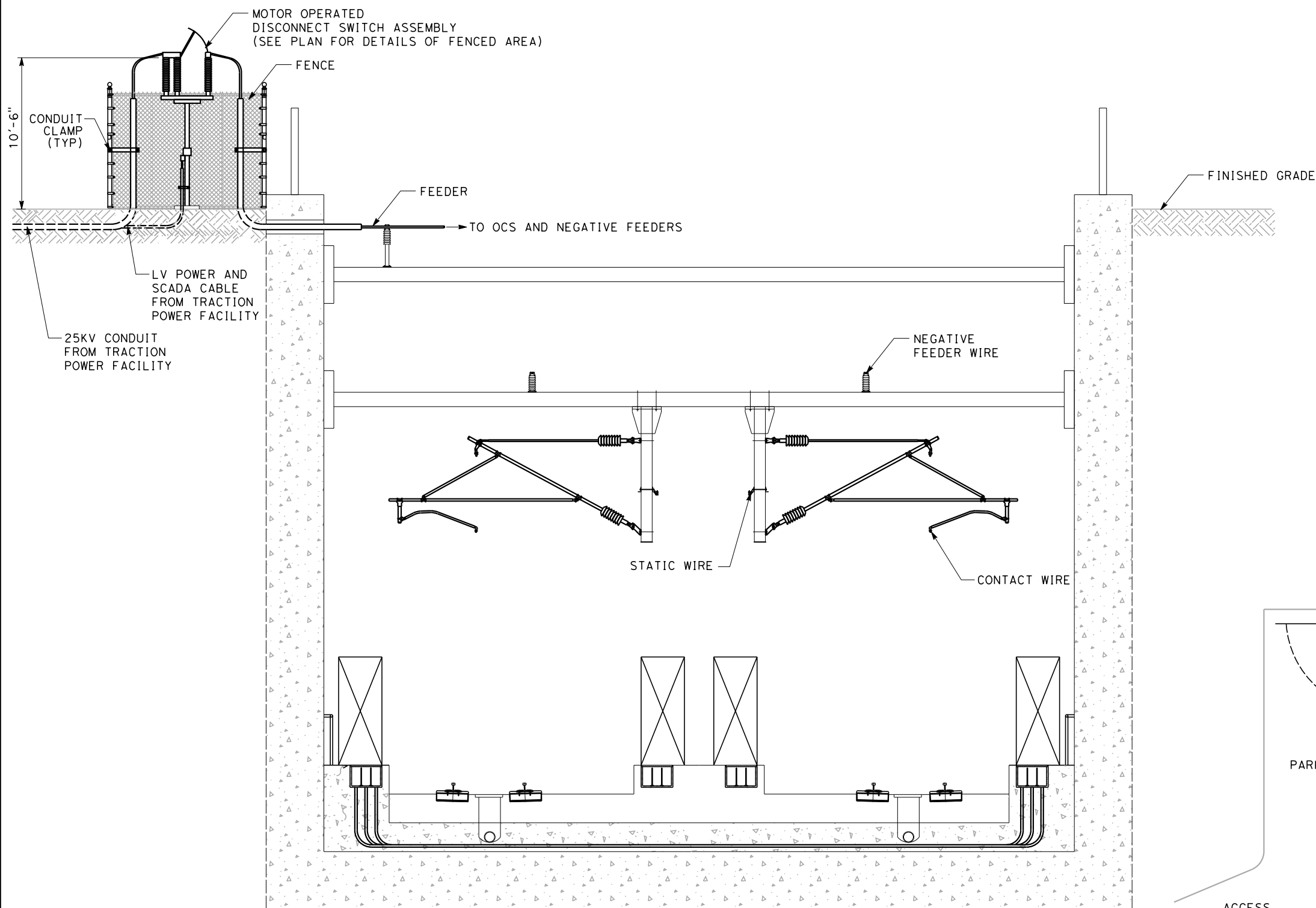

NOTES:

1. THIS IS A TYPICAL CATENARY FEEDING ARRANGEMENT IN OPEN TRENCH LOCATIONS FOR TRACTION POWER FACILITIES (TPF) THAT ARE SPACED GENERALLY FIVE MILES APART.
2. FOR TPF LOCATED ADJACENT TO THE RAILROAD ROW THE DISCONNECT SWITCH ASSEMBLY (DSA) WILL BE LOCATED WITHIN THE TPF BOUNDARY. FOR TPF LOCATED AWAY FROM THE RAILROAD ROW THE DSA WILL BE LOCATED WITHIN TO RAILROAD ROW IN A FENCED AREA. THIS FENCED AREA SHALL BE PROVIDED WITH MINIMUM TWO LOCKABLE DOORS AND ACCESS ROAD WITH PARKING FACILITY(IES). SEE DRAWINGS TM 3.1.1.3-A, TM 3.1.1.3-C AND TM 3.1.1.3-D.
3. THIS IS A TYPICAL ARRANGEMENT FOR ONE FEEDER. THE NUMBER OF DSAs WILL BE EQUAL TO THE NUMBER OF FEEDERS REQUIRED. SEE CHART BELOW FOR NUMBER OF FEEDERS REQUIRED FOR DIFFERENT TPF LOCATIONS AND TRACK CONFIGURATIONS. PROVIDE A MINIMUM WORKING CLEARANCE OF SIX FEET BETWEEN ADJACENT DSAs.
4. SEE DRAWING TM 3.1.1.3-G FOR LAYING OF DUCT BANKS.
5. FINAL CONFIGURATION AND ARRANGEMENT OF THE CONDUITS, THEIR SUPPORTS, CONDUIT CLAMPS AND OTHER ITEMS SHALL BE DETERMINED BY THE FINAL DESIGNER.
6. THE BENDING RADII OF THE CONDUITS/CABLES SHALL CONFORM TO THE RELEVANT CODE.
7. REFER TO TM 3.2.1 FOR MINIMUM STATIC AND DYNAMIC CLEARANCES BETWEEN FEEDER DROPS AND THE ALONG-TRACK NEGATIVE FEEDERS.
8. THE FRAME OF THE DISCONNECT SWITCH AND FENCE SHALL BE CONNECTED TO THE GROUND THROUGH GROUND MAT AND THE STATIC WIRES USING ACROSS-TRACK BEAM AND VERTICAL DROPS.
9. FOR ADDITIONAL INFORMATION RELATED TO THE TRENCH LAYOUT SEE DRAWINGS TM 1.1.21-J, TM 1.1.21-K AND TM 1.1.21-L.

**NUMBER OF FEEDERS (DISCONNECT SWITCH ASSEMBLIES)
FOR DIFFERENT TRACTION POWER FACILITIES**

NUMBER OF TRACKS	SUBSTATION	SWITCHING STATION	PARALLELING STATION
2	12	12	4
4	18	18	6

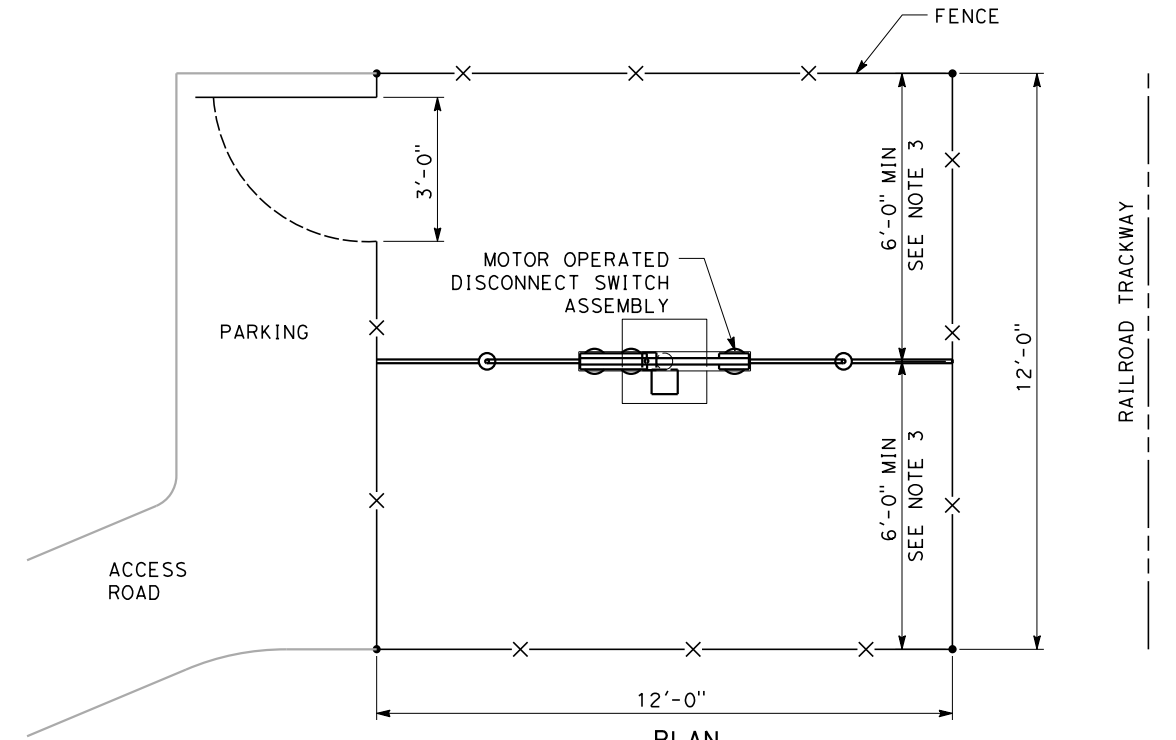

**MOTOR OPERATED DISCONNECT SWITCH ASSEMBLY
SPACE ARRANGEMENT
CABLE DETAILS OMITTED FOR CLARITY (SEE NOTE 3)**

REV	DATE	BY	CHK	APP	DESCRIPTION

DESIGNED BY
V. SIBAL
DRAWN BY
S. BURDEYNIK
CHECKED BY
M. PAZ
IN CHARGE
R. SCHMEDES
DATE
04-19-11



CALIFORNIA HIGH-SPEED TRAIN PROJECT

TYPICAL CATENARY FEEDING ARRANGEMENT
IN OPEN TRENCH LOCATIONS FOR
TRACTION POWER FACILITIES

CONTRACT NO.
13259
DRAWING NO.
TM 3.1.1.3-M
SCALE
NTS
SHEET NO.