

# California High-Speed Train Project



## TECHNICAL MEMORANDUM

### Basic High-Speed Train Tunnel Configuration TM 2.4.2

Prepared by: Signed document on file 26 Jul 2010  
Jimmy Thompson Date

Checked by: Signed document on file 27 Jul 2010  
Chris Hawkins Date

Approved by: Signed document on file 15 Nov 2010  
Ken Jong, PE, Engineering Manager Date

Released by: Signed document on file 20 Jan 2011  
Hans van Winkle, Program Director Date

Revision	Date	Description
0	27 July 09	Initial Release, R0
1	15 Nov 10	Revised to include single-bore, twin-track tunnel

Note: Signatures apply for the latest technical memorandum revision as noted above.

This document has been prepared by **Parsons Brinckerhoff** for the California High-Speed Rail Authority and for application to the California High-Speed Train Project. Any use of this document for purposes other than this Project, or the specific portion of the Project stated in the document, shall be at the sole risk of the user, and without liability to PB for any losses or injuries arising for such use.



## System Level Technical and Integration Reviews

The purpose of the review is to ensure:  
 Technical consistency and appropriateness  
 Check for interface issues and conflicts

System level reviews are required for all technical memorandums. Technical Leads for each subsystem are responsible for completing the reviews in a timely manner and identifying appropriate senior staff to perform the review. Exemption to the System Level technical and integration review by any Subsystem must be approved by the Engineering Manager.

System Level Technical Reviews by Subsystem:

Systems:	<u><i>Signed document on file</i></u> Richard Schmedes	<u>24 Jun 10</u> Date
Infrastructure:	<u><i>Signed document on file</i></u> John Chirco	<u>12 Jun 10</u> Date
Operations:	<u><i>Signed document on file</i></u> Paul Mosier	<u>25 Jun 10</u> Date
Maintenance:	<u><i>Signed document on file</i></u> Paul Mosier	<u>25 Jun 10</u> Date
Rolling Stock:	<u><i>Signed document on file</i></u> Frank Banko	<u>24 May 10</u> Date

Note: Signatures apply for the technical memorandum revision corresponding to revision number in header and as noted on cover.



## TABLE OF CONTENTS

<b>ABSTRACT .....</b>	<b>1</b>
<b>1.0 INTRODUCTION .....</b>	<b>3</b>
1.1 PURPOSE OF TECHNICAL MEMORANDUM .....	3
1.2 STATEMENT OF TECHNICAL ISSUE .....	3
1.2.1 Definition of Terms .....	3
1.2.2 Units .....	4
<b>2.0 DEFINITION OF TECHNICAL TOPIC.....</b>	<b>5</b>
2.1 GENERAL.....	5
2.2 LAWS AND CODES .....	5
2.3 BASIC TUNNEL CONFIGURATION .....	5
2.4 ROLLING STOCK, STATIC GAUGE AND DYNAMIC ENVELOPE .....	7
2.5 TUNNEL FIXED EQUIPMENT ENVELOPE AND CLEARANCES .....	7
2.6 OTHER TUNNEL SIZE PARAMETERS .....	10
2.7 DESIGN ASSUMPTIONS BASED ON POLICY CONSIDERATIONS.....	11
<b>3.0 ANALYSIS AND ASSESSMENT .....</b>	<b>12</b>
3.1 VENTILATION, TRANSIENT AIR PRESSURES, AERODYNAMICS AND TEMPERATURE.....	12
3.2 TUNNEL DIMENSIONS BASED ON MEDICAL HEALTH CRITERIA .....	18
3.3 MITIGATION MEASURES .....	21
<b>4.0 CONCLUSIONS AND RECOMMENDATIONS .....</b>	<b>22</b>
<b>5.0 SOURCE INFORMATION AND REFERENCES.....</b>	<b>24</b>
<b>6.0 DESIGN MANUAL CRITERIA .....</b>	<b>25</b>
6.1 BASIC TUNNEL CONFIGURATION .....	25
<b>APPENDICES.....</b>	<b>30</b>



## ABSTRACT

This Technical Memorandum establishes approximate finished dimensions for bored, mined and cut-and-cover tunnels in which high-speed passenger trains run exclusively. The document has been prepared, for use during Preliminary Design in determining alignment corridors and right-of-way requirements, and in the development of cost estimates.

Two basic tunnel configurations are assumed:

- Twin tunnels, with a single track in each tunnel
- A single tunnel with two tracks and a central separation wall between each track

Tunnel shapes are circular (TBM driven) for bored tunnels, arched for mined tunnels, and rectangular for cut-and-cover tunnels.

The basic tunnel configurations consider train profiles, static gauge, kinematic envelope, fixed equipment envelope, tangent and superelevated track, construction tolerances, escape walkways, pantograph catenary and support structure, ballasted or fixed (slab) track, and drainage. These items are at an early stage of design and are subject to refinements which may affect finished tunnel dimensions.

The tunnel dimensions are calculated based on the European Technical Specifications for Interoperability (TSI) requirements for maximum pressure variation in tunnels and underground structures for trains complying with high-speed rolling stock at the maximum operating speed of 220 mph. The purpose of limiting the pressure changes is to mitigate adverse health effects or discomfort to passengers and workers, and these criteria are known as the medical health criteria. The key TSI requirement is for a 10 kPa (1.45 psi) maximum pressure variation between the tunnel and interior of the train. This preliminary assessment of the minimum free tunnel cross sectional areas to comply with medical health criteria at critical train speeds and tunnel lengths are established from data provided in UIC 779-11R "Determination of Railway Tunnel Cross-Sectional Areas on the Basis of Aerodynamic Considerations."

The rolling stock is assumed to be excellently sealed and it is therefore unnecessary to size the tunnels for the UIC aural comfort criteria, which would result in larger tunnel cross sections. TSI does not regulate aural comfort criteria. Aural comfort criteria are regulated at the national level and addresses unsealed and partially sealed rolling stock.

As tunnel length increases, medical health criteria become less critical and the effects of aerodynamic drag on the trains in tunnels increases significantly compared with open track operation. Heat generated from the aerodynamic drag, air conditioning of the trains, and systems, builds up in the tunnels. These effects can be mitigated by increasing the tunnel size, cooling the tunnels, reducing the aerodynamic drag of the trains, and increasing the power available to the trains. Proposed methods of calculation of aerodynamic drag in open air and tunnels are detailed in EN 14067 Railway Applications – Aerodynamics, Parts 1 to 5, which were issued between 2003 and 2006. Some of these methods have been developed further by the study of pressure waves and the development of the medical health criteria and associated software in UIC 779-11 which was issued in 2005. A qualitative discussion of these complex issues is included in this memorandum. Quantitative analysis will be carried out during subsequent design phases.

Various measures can be used to mitigate aerodynamic effects, including pressure relief ducts between tunnels, airshafts and ground surface. These mitigation measures will be addressed along with a quantitative analysis of aerodynamic effects in future studies.

Transient air pressures that are not reflected back along the tunnel exit the tunnel portal as a sonic boom of a similar magnitude to a gunshot. Potential mitigation measures for sonic booms are discussed.



The following factors may influence the finished tunnel dimensions and will be studied further during detailed design:

- Portals, junctions, interfaces and transitions between bored tunnels, cut-and-cover tunnels and other structures
- Train generated heat
- Aerodynamic drag



## 1.0 INTRODUCTION

### 1.1 PURPOSE OF TECHNICAL MEMORANDUM

This technical memorandum establishes approximate finished dimensions for new construction of bored and cut-and-cover tunnels in which high-speed passenger trains run exclusively. This document has been prepared for use in determining alignment corridors, right-of-way requirements, and in the development of cost estimates for the preliminary design level.

### 1.2 STATEMENT OF TECHNICAL ISSUE

The basic tunnel dimensions are established to conform to the European Technical Specifications for Interoperability (TSI) requirements for a 10 kPa (1.45 psi) maximum pressure variation in tunnels. Tunnels were sized for the maximum allowable speed of 220 mph. For comparison, the areas were also calculated for train speeds of 205 and 250 for the bored and cut-and-cover tunnels.

The purpose of limiting the rapid pressure changes is to mitigate adverse health effects or discomfort to passengers and workers, and these criteria are known as the medical health criteria.

The basic tunnel configurations developed incorporate train profiles, static gauge, kinematic envelope, tangent and superelevated track, construction tolerances, escape walkways, pantograph catenary and support structure, ballasted or fixed (slab) track, and drainage. Wherever possible, allowances have been made to accommodate future changes or those items which have not yet been defined such as fixed equipment including cables and pipes. No allowance has been made for catenary tensioning devices such as weights, and ventilation fans, as it is assumed that they will be accommodated in niches outside of the running tunnels.

Assessment and development of basic design guidelines for the single, twin-track tunnels, portals, shafts and other tunnel structures and the interfaces between tunnels and portals have not been considered in this technical memorandum and will be the subject of separate technical memoranda.

#### 1.2.1 Definition of Terms

The following technical terms and acronyms used in this document have specific connotations with regard to California High-Speed Train system.

Blockage Ratio Ratio of train cross section area to tunnel cross section area

Free Cross Section Area The standard tunnel cross section area excluding clearance for tunnel design details and fixed equipment

Medical Health Criterion Maximum pressure variation (peak-to-peak value) in the tunnel (outside of the train) independent of time.

Passenger Aural Comfort Criteria Maximum pressure change inside the train within a specified period of time to limits the discomfort on passenger ears when passing through a tunnel.

Pressure Comfort Conditions where there is no passenger ear discomfort due to pressure change.

Pressure Tightness Coefficient Time in which the difference between internal and external pressures upon a stepwise pressure change decrease from 100% to approximately 38% of the initial pressure difference.

Sealing Quality The capacity of the train to limit inside pressure change within given limits.



### Acronyms

Authority	California High-Speed Rail Authority
CHST	California High-Speed Train
CHSTP	California High-Speed Train Project
HST	High-Speed Train
KPH/kph	Kilometers per Hour
MPH/mph	Miles per Hour
NFPA	National Fire Protection Association
THSR	Taiwan High Speed Rail
TM	Technical Memorandum
TSI	European Technical Specifications for Interoperability
UIC	Union Internationales des Chemins de fer (International Union of Railways)

### **1.2.2 Units**

The California High-Speed Train Project is based on U.S. Customary Units consistent with guidelines prepared by the California Department of Transportation and defined by the National Institute of Standards and Technology (NIST). U.S. Customary Units are officially used in the United States, and are also known in the U.S. as “English” or “Imperial” units. In order to avoid confusion, all formal references to units of measure should be made in terms of U.S. Customary Units. In the case where source documents use metric units, the metric units have been retained and a conversion to U.S. Customary Units follows.





## 2.0 DEFINITION OF TECHNICAL TOPIC

### 2.1 GENERAL

This Technical Memorandum establishes approximate finished dimensions for bored and cut-and-cover tunnels in which high-speed passenger trains operate. The dimensions are based on the European Technical Specifications for Interoperability (TSI) requirements for maximum pressure variation in tunnels and underground structures for trains complying with high-speed rolling stock at the maximum operating speed of 220 mph. The purpose of limiting the pressure changes is to mitigate adverse health effects or discomfort to passengers and workers, and these criteria are known as the medical health criteria.

### 2.2 LAWS AND CODES

Assessment, compliance and/or demonstration of equivalency for applicable laws and codes will follow.

### 2.3 BASIC TUNNEL CONFIGURATION

Several basic tunnel configurations are used for railway tunnels. Common configurations for high-speed passenger, conventional passenger, and freight railway tunnels are:

#### Bored Tunnels

- Twin single-track tunnels, each with a single-track, and having cross passages between tunnels.
- Single tunnel with twin-tracks with separation wall and escape walkways between tracks and access doors in separation wall.
- Single tunnel with twin-tracks without separation wall, escape walkways adjacent to tunnel walls. Refuge areas and/or access shafts to surface are usually required for long tunnels.

#### Cut-and-Cover Tunnels

- Single-track twin boxes with escape shafts or cross-passages.
- Twin-track, single box with separation wall and escape walkways between tracks, doors in separation wall.
- Twin-track, single box without separation wall, escape walkway by walls of tunnel, refuges and escape shafts to surface usually required for longer tunnels.

Several factors must be considered in the selection of the tunnel configuration including the following:

- Train speed
- Alignment
- Tunnel length
- Aerodynamics
- Ventilation
- Fire and life-safety
- Depth of tunnel
- Access and egress
- Geologic conditions and ground stability
- Groundwater conditions
- Right-of-way
- Method of construction
- Environmental considerations
- Operations and maintenance
- Capital, operating, and maintenance costs
- Construction schedule

It is beyond the scope of this technical memorandum to address all these factors in detail. Assumptions have been made in order to determine basic finished tunnel dimensions.



A fire, life-safety and passenger evacuation strategy for each tunnel configuration must be developed in coordination with the authority having jurisdictions for operational safety as this is critical to establishing the appropriate tunnel configuration at tunnel locations.

Assessment and development of basic design guidelines for the portals, shafts and other tunnel structures will be the subject of separate technical memoranda.

### **2.3.1 Bored Tunnels**

This technical memorandum considers a twin, single-track tunnel and a single, double-track tunnel with divider wall configurations for bored tunnels. These arrangements have been established as the basic tunnel configuration to be used by designers in advancing the preliminary design level of the high-speed rail corridor.

The twin, single-track tunnel arrangement is a common configuration in construction of new transit systems and for tunnels carrying shared high-speed passenger and freight trains. It has also been used for passenger only high-speed rail. A recent example of passenger only high-speed rail is the HS1 line in London (formerly known as Channel Tunnel Rail Link / CTRL Phase 2 project). The configuration is most common with shared use (passenger and freight train) tunnels, as the risk of fire and fire loading for freight trains is much higher than from passenger trains. A primary consideration for this configuration is to include each track in a separate tunnel and provide a refuge area or escape route from one tunnel to the other tunnel in the event of a fire or emergency condition. For twin bore tunnels, it is desirable to maintain a center pillar roughly equal to the tunnel diameter in order to limit stresses between tunnel bore and allow for excavation of the second bore.

The alternative of a single, twin-track tunnel configuration has a separation wall with doors between tunnels. An example of this type of tunnel with a separation wall is the Groene Hart high-speed train tunnel in Holland. This soft ground tunnel was driven by a single large TBM and carries high-speed train lines. Examples of single tunnels carrying twin-tracks without a separation wall include the majority of the high speed train tunnels constructed in Asia, including those for the Taiwan High Speed Rail Project.

### **2.3.2 Cut-and-Cover Tunnels**

This technical memorandum considers both twin, single-track and single, twin-track box configurations for the cut-and-cover tunnels. The latter is assumed to have a separation wall between tracks.

### **2.3.3 Interfaces**

Interfaces and transitions between bored and cut-and-cover tunnels and portals have not been considered in this technical memorandum.

### **2.3.4 Finished Shape and Method of Construction**

Assumptions for shape and method of construction have been made for both bored and cut-and-cover tunnels. It is beyond the scope of this study to discuss alternate tunnel shapes and the various methods of tunnel excavation and support that are closely related to the tunnel shape.

#### **2.3.4.1 Bored Tunnel**

The majority of the bored tunneling on the high-speed rail alignment is through the Pacheco Pass, Tehachapi and the San Gabriel mountains. Some of the tunneling is likely to encounter unstable and faulted ground, high water inflow quantities, and high ground water pressures. For environmental reasons, it may be undesirable to lower the water table during construction. Some of the tunnels will be several miles in length and access will be limited. TBM bored tunnels are well suited to these conditions and will result in a circular shaped tunnel. For the purposes of this document, the finished shape of the bored tunnels is therefore assumed to be circular and the method of construction to be TBM-driven. There are alternative methods of excavation able to achieve similarly shaped tunnels (arched or elliptical), such as drill and blast or sequential excavation method, though these methods may require pre-treatment of the ground to prevent water inflows. The methodology and conclusions of this study may also be applicable to these tunnels.



Tunnels will have a watertight, smooth concrete lining for safety, durability, low maintenance and reduced aerodynamic drag.

#### **2.3.4.2 Cut-and-Cover Tunnel**

For the purposes of this study, the finished shape of cut-and-cover tunnels is assumed to be rectangular. The method of construction and excavation support will vary according to environmental and access constraints, depth of excavation, utilities, sensitive structures, ground settlement considerations, presence of water, maintenance of traffic during construction, and availability of easements and staging areas adjacent to the permanent structures.

### **2.4 ROLLING STOCK, STATIC GAUGE AND DYNAMIC ENVELOPE**

Dimensions for static and dynamic envelopes in the tunnels are the same as for other structures, and development is documented in TM 1.1.10 - Structure Gauge.

#### **2.4.1 Rolling Stock**

Train profiles for candidate high-speed rail rolling stock were prepared to enable calculation of the train cross sectional areas. These drawings are included in Appendix A. Key dimensions and cross sectional areas are summarized in Appendix B. The information was derived from a variety of sources and requires verification following selection of the high-speed rolling stock. The cross sectional areas of rolling stock shall only be relied on for the purpose of calculating the free tunnel cross sectional area required to comply with the TSI medical health criteria and aerodynamic drag calculations.

##### **2.4.1.1 Duplex / Bi-level**

Shinkansen Bi-level and TGV Duplex train profiles are included in Appendix A. A prototype of an AGV Duplex has as not yet been manufactured.

##### **2.4.1.2 Single Level**

Shinkansen N700 and AGV (prototype) Single Level train profiles are included in Appendix A.

#### **2.4.2 Static Gauge**

A composite high-speed vehicle static gauge has been developed that is similar to UIC GC gauge. Refer to Technical Memorandum TM 1.1.10 - Structure Gauges. Correspondence with Alstom refers to the TGV duplex and a future AGV duplex vehicle as fitting within a G3 gauge. It is noted that the top of the G3 outline is different to the AGV single-level.

#### **2.4.3 Dynamic Envelope**

##### **2.4.3.1 Tangent and Superelevated Track**

A maximum superelevation of 7 inches has been established as a CHSTP system requirement. Maximum superelevation, if used in any of the tunnel alignments, is critical to the minimum width calculation for cut-and cover tunnels. Refer to Technical Memorandum TM 1.1.10 - Structure Gauge.

### **2.5 TUNNEL FIXED EQUIPMENT ENVELOPE AND CLEARANCES**

The tunnels are required to allow sufficient clearance between the various elements present in the tunnels including all necessary fixed equipment and rolling stock.

Conceptual design drawings have been developed to illustrate various types, and typical arrangement and locations of continuous and intermittent fixed equipment and the supporting tunnel structure as described in this section. These drawings will be released in the future and will be subject to change as requirements for, and design of, fixed equipment is progressed. The drawings should be read in conjunction with Directive Drawings for tunnel configurations and sizes and typical cross section drawings developed for TM 1.1.21 - Typical Cross Sections. Arrangements and locations will vary at tunnel enlargements, niches, cross-passages and interfaces with other tunnel and structural sections.



The tunnel fixed equipment envelope is shown on the Directive Drawings and has been developed from the generic fixed equipment envelope shown on Directive Drawings 1.1.10-C and 1.1.10-D as described in the following text. The tunnel fixed equipment envelope also encompasses the overhead catenary system electrical clearances. Optimization of the fixed equipment envelope and other clearances may be possible once the design of the fixed equipment is complete.

### **2.5.1 Pantograph and Catenary Electrical and Mechanical Envelopes**

The pantograph and electrical clearance envelopes shall be the standard clearances required for high-speed OCS designs in accordance with TM 3.2.3 – Pantograph Clearance Envelopes. Standard OCS configurations are currently required in all tunnels. Restricted tunnel clearances which may require special OCS configurations will be evaluated on a case by case basis and in low speed areas after a design variance has been assessed and approved.

Refer to Technical Memorandum TM 3.2.3 - Pantograph Clearances.

### **2.5.2 Tunnel Fixed Equipment Envelope**

The distance from the walkway envelope to the edge of the walkway has been set to establish the tunnel diameter consistent with the operating assumption that personnel will not be in the tunnel outside the train during revenue operation.

A provisional list and size of continuous fixed equipment which may be located within the free cross sectional area of the tunnel was developed in order to make a preliminary estimate of the cross sectional area which is occupied by the equipment and the clearances required for the equipment in the fixed equipment envelope. The list has been prepared only to establish a preliminary estimate of the cross sectional area occupied by this equipment and the clearances required in the fixed equipment envelope. It is not intended that for this to be a definitive list nor does it represent final size of equipment. A list of intermittent fixed equipment that does not need to be included in the estimate of cross sectional area is included for completeness.

### **2.5.3 Continuous Equipment**

The following continuous equipment may be located in the free tunnel cross sectional area:

- 6 x 6" OD High Voltage Electric cables
- 10 x 3" OD Low Voltage Electric cables
- 8" OD Standpipe (fire line)
- 2" OD Emergency air pipe
- 13" OD Sump pump discharge pipe
- 1" OD Leaky feeder cable
- 1" OD Earthing tape and corrosion protection
- 2" OD handrail
- Communications and signaling equipment
- OCS and feeder wires
- Sliding cross passage doors (only required in double track tunnels with separation wall between tracks)

An allowance of 20 square feet is provided to allow for the continuous fixed equipment and for pantograph and catenary wire equipment in the free tunnel cross sectional area. It is recognized that this is a conservative estimate as some of the equipment may be accommodated in cableways and duct banks cast into the escape walkway and tunnel invert concrete and will not be in the free tunnel cross sectional area.



## 2.5.4 Intermittent Equipment

The following intermittent equipment may be located in the free tunnel cross sectional area and a space allowance will be necessary outside the fixed equipment envelope. No allowance in the free cross sectional area is necessary as the equipment is not continuous.

- Signage
- Tunnel walkway lighting
- Emergency radio antennae
- Fire telephone box
- Blue light station (at cross passages)
- Rail lubricator tank
- Train control / signal case
- Fire extinguishers
- Ventilation equipment such as jet fans

## 2.5.5 Other Equipment

### 2.5.5.1 Ventilation Fans

An allowance has been made for ventilation jet fans in the basic tunnel configuration. Other larger types of fans such as axial ventilation fans are assumed to be located in niches adjacent to tunnels. Niches and enlargements present no difficulties in cut-and-cover and rock tunnels but may present a significant construction challenge in bored soft ground tunnels where groundwater pressure is present.

### 2.5.5.2 OCS Tensioning Devices and Disconnect Switches

OCS tensioning devices will be required at approximately 5000 foot intervals and OCS disconnect switches will be required at approximately 3 mile intervals. The tensioning devices will be designed to fit within the standard cross section or in niches adjacent to tunnels. OCS switches may be located in similar position as the jet fans or will be located in tunnel enlargements at necessary intervals. These elements will not be continuous and so do not need to be taken into account in the free tunnel cross section calculations. Niches and enlargements present no difficulties in cut-and-cover and rock tunnels but may present a significant construction challenge in bored soft ground tunnels where groundwater pressure is present.

### 2.5.5.3 Chiller Units and Cooling Pipes

The requirement for chiller units and cooling pipes will be the subject of a separate study. An allowance for cooling pipes has been made in the basic tunnel configuration. Chiller units would be located in niches. The requirement for cooling of the tunnels to minimize heat buildup from aerodynamic drag will be the subject of study during detailed design.

### 2.5.5.4 Pump Sumps

No allowance for pump sumps has been made in the basic tunnel cross section. Pump sumps are assumed to be located in cross passages adjacent to tunnels or, if operation and maintenance requirements allow, the sumps could be located below the invert of the running tunnels.

### 2.5.5.5 Bonding and Grounding

TM 3.2.6 presents the traction electrification system requirements grounding and bonding requirements and for protection against electric shock.

TM 3.3.4 presents the grounding and bonding requirements for train control and communications.



## 2.6 OTHER TUNNEL SIZE PARAMETERS

### 2.6.1 Invert

#### 2.6.1.1 Drainage

##### Concrete Trackform

Trackwash and Firemain - It is assumed that water from trackwash and fire main testing will be directed along the invert of bored and cut-and-cover tunnels in a drain under the tunnel invert to prevent water ponding in the tunnel. The channel has not been sized.

Designed Hydrostatic Pressure Relief of Lining/ Drained Tunnels - It is assumed that all tunnels will be lined and undrained for environmental reasons. No allowance has been made for deliberate drainage of water from behind the lining to reduce water pressure.

Leakage - There may be relatively small quantities of water continuously leaking through the lining after construction is complete. This water will be directed to drains below the invert. Water flowing on the invert may not be acceptable during high-speed revenue operation as it can be sucked up during passage of trains.

Ballasted Track - This will require a more complex drainage system below or within the ballast and has not been studied in detail.

### 2.6.2 Trackform

#### 2.6.2.1 Bored Tunnels

An allowance of approximately 3-feet depth from top of invert concrete to lining at tunnel center point has been made in the bored tunnels. This will allow use of a direct fixation (slab) or ballasted trackform and maintain sufficient clearance for either superelevated or tangent track. A direct fixation (slab) trackform is preferred in tunnels and is standard practice in new construction for rail tunnels due to its low maintenance requirements. Maintenance is a key consideration in tunnels due to restricted access, limited space for tamping activities, and short possession times.

#### 2.6.2.2 Cut-and-Cover Tunnels

An average allowance of approximately 3'-2" depth from top of invert concrete to lining at tunnel center point has been made in the cut-and-cover tunnels. This will allow use of a direct fixation (slab) or ballasted trackform and maintain sufficient clearance for both superelevated and tangent tracks. As a guideline, ballasted track on viaducts typically requires a minimum depth of ballast of approximately 12 -14 inches below cross ties. If slurry walls are constructed as permanent tunnel walls, a connection between the slurry wall reinforcement cages and invert concrete slab reinforcement will be required and this may require a flat slab invert arrangement with steps to adjust for changes in level. Hence a generous allowance for trackform concrete has been made to accommodate all possible methods of construction.

### 2.6.3 Escape Walkway

The horizontal and vertical location of the escape walkway cannot be confirmed until a passenger evacuation strategy has been adopted and approved for the CHSTP. Assumptions for walkway size and placement were made based on TSI requirements and European practice. Established high-speed rail practice is to locate the escape walkway at or near the level of the rail rather than at the level of the vehicle door sill and provide a step on the rolling stock to allow passengers to disembark. The assumed envelope of the escape walkway are shown on the drawings achieve the requirements of NFPA 130.

### 2.6.4 Construction Tolerances

#### 2.6.4.1 Bored Tunnel

A construction tolerance allowance of 6 inches in diameter has been allowed.



#### **2.6.4.2 Cut-and-Cover Tunnel**

A vertical construction tolerance of 1 in 100 for construction of excavation support walls (if required) has been assumed. Typical depth to invert is assumed to be 50 feet which results in a 6 inch vertical tolerance on each of the two vertical walls. A horizontal construction tolerance allowance of 4 inches is assumed for the soffit slab.

#### **2.6.5 Allowances for Permanent Post Construction Ground Movements**

No allowances for permanent, location-specific, post-construction ground movements associated with seismicity, swelling ground, fault movements, landslides and other loading conditions has been made. The magnitude of these movements will be determined by the regional consultants and allowance made in the tunnel cross section as necessary.

#### **2.6.6 Clearances Necessary in Case of Derailment**

Derailment may occur during a seismic or other event. Trackside containment structures and/or derailment devices may be fitted to the rolling stock to limit the offset distance that rolling stock will travel from the rail in tunnels. The fixed equipment envelope should include an allowance to mitigate against the rolling stock hitting fixed equipment in the event of derailment.

### **2.7 DESIGN ASSUMPTIONS BASED ON POLICY CONSIDERATIONS**

The following policy issues are assumed in the development and presentation of the information contained in this design guidance.

The assumptions for the basic tunnel configuration are detailed in the following subsections. The tunnel configuration incorporates train profiles, static gauge, kinematic envelope, tangent and superelevated track, construction tolerances, escape walkways, pantograph catenary and support structure, ballasted or fixed (slab) track, and drainage. Many of these items are at an early stage of design and are subject to changes which may affect finished tunnel dimensions. Where possible, allowances have been made to accommodate future changes or those items which have not yet been defined.

- Bi-level high-speed rolling stock may be used.
- The AGV single-level train, a prototype not yet in production, does not comply with the CHSTP policy requiring the trainset to be a proven technology.
- Rolling stock will have excellent sealing characteristics similar to or better than ICE-3 and Shinkansen trains.
- The crosspassages and or doors connecting the single-track running tunnels will be completely sealed to allow trains to travel in opposite directions at the same time within the single-track tunnels, or if connections are not sealed, trains will not be allowed to pass in opposite directions within tunnels at the same time.
- It will not be possible to run trains at speeds in excess of 220 mph in the tunnels and meet the medical health criteria.



## 3.0 ANALYSIS AND ASSESSMENT

### 3.1 VENTILATION, TRANSIENT AIR PRESSURES, AERODYNAMICS AND TEMPERATURE

The following key issues are related to the tunnel free cross sectional area, length of tunnel and tunnel portals, and are discussed in the following sections.

- Transient Air Pressures
- Aerodynamic Drag
- Temperature
- Sonic Booms at Tunnel Portal

Emergency ventilation is not considered to be critical to sizing the tunnels. The purpose of emergency ventilation is to provide smoke control and purging in the event of a fire in the tunnel so that passengers can escape from the stationary train to the adjacent tunnel via the nearest cross passage. It is assumed that sufficient emergency ventilation can be provided for a given free tunnel cross sectional area in the form of vent shafts to surface and vent fans located at intervals in the shafts and niches in the tunnel in a similar way to typical mass transit railway tunnel emergency ventilation system, or jet fans in the running tunnels. The speed of the train is not relevant as it is stationary during the exiting procedure and short tunnels will be unlikely to need as much emergency ventilation as long tunnels.

#### 3.1.1 Transient Air Pressures

A train passing through a tunnel causes a very complex, unsteady flow field. The pressure transients are mainly produced by the entrance and exit of the nose and tail of the train. The compression and expansion waves propagate along the tunnel with the speed of sound relative to the local airflow. A proportion of these sonic waves are reflected at the ends of the tunnel and partly reflected if passing a nose or tail of a train. The remainder of the sonic waves exit the tunnel portal as a sonic boom. The mitigation of sonic booms is discussed in a following section.

The sonic waves are reflected back along the tunnels with compression waves reflected as expansion waves, and rarefaction waves as compression waves. This results in a complex superposition of waves.

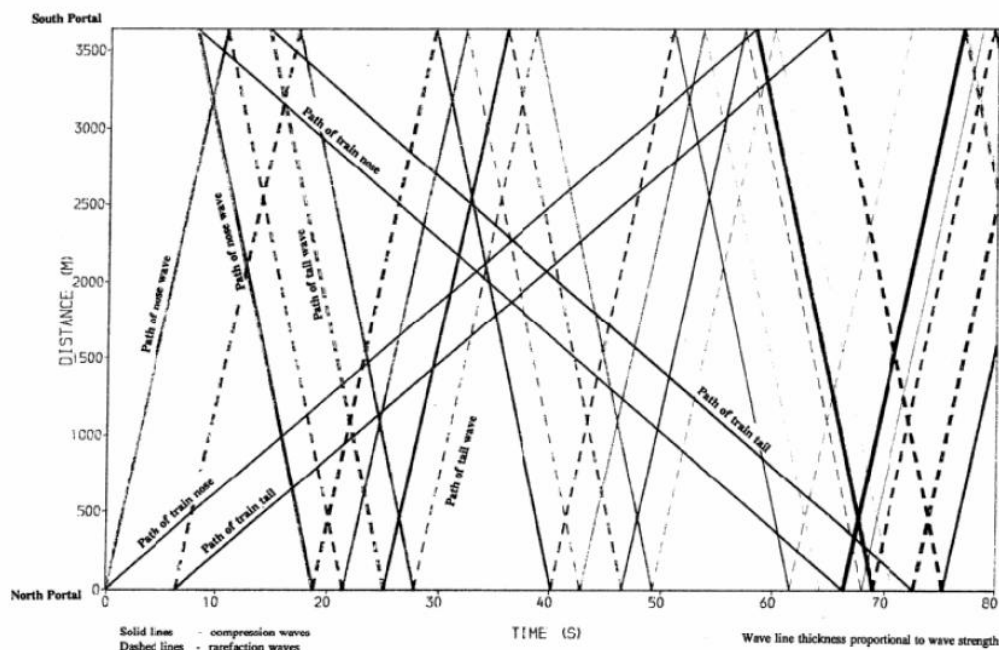

**Figure 3-1 Impact of the Combinations of Pressure Waves for Two Trains Travelling in Opposite Directions**





For waves of the same sign the interference is additive and may cause severe pressure gradients in a short time interval. The train therefore travels through a combination of waves which mainly depend on, but are not limited to, train speed, train aerodynamic characteristics, tunnel cross-section (dimensions) and the tunnel geometry (shape).

A representation of the waves generated by two trains passing each other while travelling in opposite directions is shown in Figure 3-1.

This figure shows that each train is traveling through multiple combinations of pressure waves. The train noses and train tails are not affected by the same combinations. As a result, static pressure experienced by train and passenger vary along the tunnel length as shown in Figure 3-2.

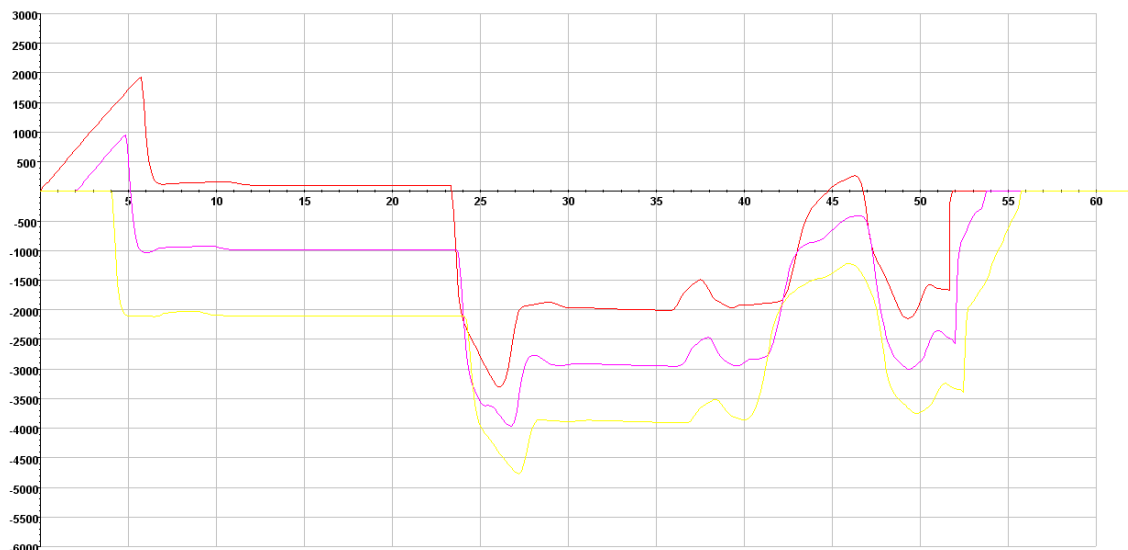

**Figure 3-2 Static Pressure Variation (Pa) Versus Time (s)**

Figure 3-2 illustrates static pressure variation (Pa) versus time (s) at three locations on the train while the train is running along the tunnel. Data used in this example is as follows:

- Train length – 400 m (1312 ft);
- Tunnel length – 5000 m (3.1 miles);
- Train speed – 350 kph (220 mph);
- Blockage Ratio (train to tunnel cross section ratio) - 0.15

Transient air pressures are highest in short tunnels and are reduced in long tunnels. The transient pressures also increase with train speed.

### 3.1.2 Effect of Transient Air Pressures on People

There are two concerns that result from these transient pressure waves and both are related to the effects of air pressure on people:

- Comfort criteria that relates to changes in pressure over time and affects people in unsealed trains, and;
- Medical health criteria that are related to instantaneous changes in pressure and may also affect people in sealed trains if there is a sudden loss of sealing.

If unsealed trains are specified, a preliminary assessment of tunnel size is obtained using the comfort criteria. If sealed trains are specified, the comfort criteria do not apply, and medical health criteria can be used to provide a preliminary assessment of required tunnel size. Note that unsealed trains (comfort criteria) require larger tunnels and/or reduced allowable speeds compared with sealed trains (medical health criteria).



### Comfort Criteria

Comfort criteria relate to rapid and significant changes of pressure across the ear drum and affect people travelling in unsealed trains. The pressure changes on an unsealed train are typically less than 4 kPa (0.58 psi) which is small compared with the 25 kPa (3.6 psi) routinely experienced on a civil aircraft. However the rate of change of pressure experienced on an unsealed train are 20 kPa to 50 kPa per second (2.9 psi to 7.25 psi per second) which is much greater than the 0.02 kPa (0.003 psi) for aircraft descent and 0.04 kPa (0.006 psi) for aircraft ascent. Even people with normal unblocked Eustachian tubes have no time to adjust by active means such as swallowing or passive means such as the automatic venting of the middle ear. Each country has different comfort criteria requirements and there are no TSI requirements for comfort criteria. The pressure comfort criteria for different countries are compared in UIC 779-11R Appendix A.

CHST rolling stock will be specified to have excellent sealing characteristics similar to Shinkansen and the ICE-3 rolling stock, and comfort criteria will not apply. Supply and maintenance of extremely well-sealed trains is a high cost item and will require careful specification and design of rolling stock.

Sealing of trains is discussed in both UIC 779-11R and UIC 660 OR – Measures to ensure the technical compatibility of high-speed trains.

The definition of sealing of trains (otherwise known as pressure tightness) is defined in UIC 779-11 Appendix F.3. The greek letter ( $\tau$ ) is used to express the co-efficient of pressure tightness and the suffix “Dyn” (for dynamic) is used to differentiate this co-efficient from the static pressure tightness co-efficient.

$T_{dyn}$  is expressed in seconds as the time taken for the difference between external and internal pressures to decrease from 100% to approximately 38% of the initial difference and is given by the equation:

$$\tau_{dyn} = \Delta p(t) / \Delta p_{int} / \Delta t$$

where:

$\Delta p(t)$  = differential pressure ( $p_{ext} - p_{int}$ ), at time  $t$

$P_{ext}$  = pressure external to the train, varies with time (=  $p_{ext}(t)$ )

$P_{int}$  = train internal pressure, varies with time (=  $p_{int}(t)$ )

The pressure attenuation with respect to time inside a train for two different sealing values ( $T = 0.5$  seconds and  $T = 5$  seconds) is given in Figure 3-3.



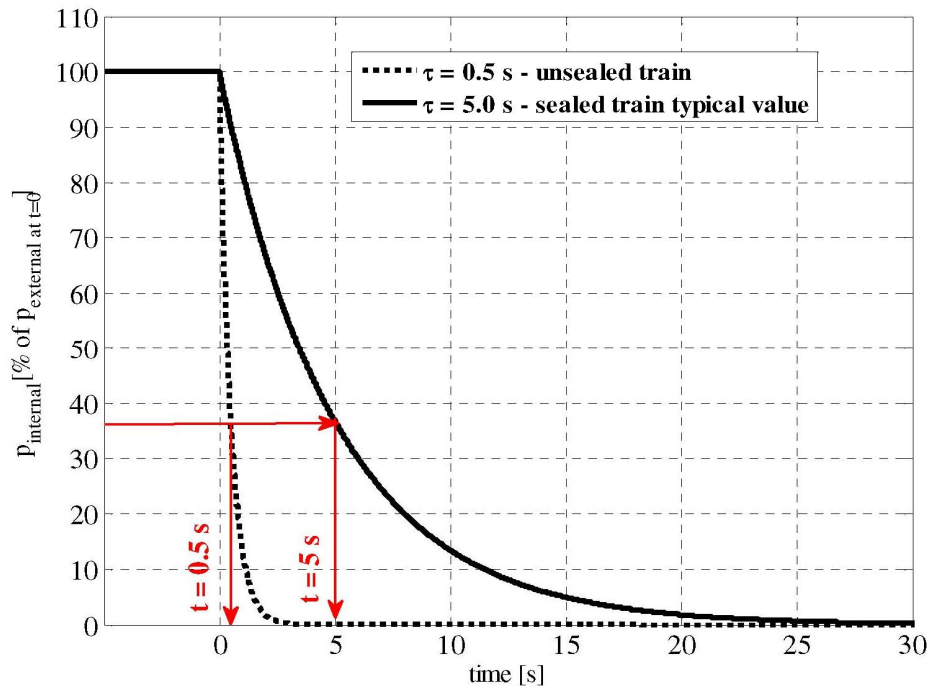

**Figure 3-3 Static Pressure Variation (Pa) Versus Time (s)**

A summary of typical T values for different train types is given in Table 3-1.

Train type	Pressure sealing coefficient
unsealed train (e.g. regional transport)	$\tau < 0.5$ s
poorly sealed train (e.g. Eurocity)	$0.5 \text{ s} < \tau < 6$ s
well sealed train (e.g. ICE1, TGV)	$6 \text{ s} < \tau < 15$ s
excellently sealed train (e.g. ICE 3, AGV)	$\tau > 15$ s

**Table 3-1 Typical T Values based on Sealing Characteristics**

Japanese Shinkansen rolling stock is understood to have T values equal to or better than T = 25 seconds which is superior to European manufactured rolling stock. This excellently sealed rolling stock has been developed primarily due to the large percentage of tunnels by length on the Shinkansen system (tunnel length is greater than 30% of total track length) and due to the small free cross sectional area of the twin track tunnels.

The Japanese Shinkansen rolling stock is continuously internally pressurized to further improve the sealing characteristics of the train. This slight internal pressurization is achieved using the air conditioning system and also prevents ingress of dust and dirt.

Testing of T values for rolling stock is defined in UIC 660 OR and consists of a full scale test involving pressurizing the interior of the carriage and measuring the drop in pressure over time.

#### Medical Health Criteria

Medical health criteria relate to pressure differences across the ear drum which can give rise in extreme cases to ear damage. The extreme case that gives cause for concern is rapid decompression or compression, which could occur if the sealing system of a sealed passenger train compartment suddenly failed due to a window breaking, for example. Note that these pressure differences also affect people outside the train who may be stationary. TSI requirements were developed from advice received by UIC from a group of medical experts who recommended limiting allowable peak to peak pressure variations to 10 kPa (3 feet head of water).

The medical health criteria are specified in TSI, Infrastructure Section, Clause 4.2.16.1 which states:

*“General requirements*

*The maximum pressure variation in tunnels and underground structures along any train complying with the High-Speed Rolling Stock TSI intended to run in the specific tunnel shall not exceed 10 kPa during the time taken for the train to pass through the tunnel, at the maximum permitted speed.*

*Lines of category I*

*The free cross-sectional area of the tunnel shall be determined so as to comply with the maximum pressure variation indicated above, taking into account all the types of traffic planned to run in the tunnel at the maximum speed at which the respective vehicles are authorized to run through the tunnel.*

*Lines of categories II and III*

*On these lines, the maximum pressure variation indicated above shall be met.*

*If the tunnel is not modified to meet the pressure limit the speed shall be reduced until the pressure limit is met.”*

### **3.1.3 Aerodynamics**

One of the characteristics unique to high-speed train operation is the significance of aerodynamic effects occurring along the track. The aerodynamic resistance acting against the train movement is of quadratic nature so that a high-speed train moving in free air is subject to similar aerodynamic limitations as a low flying aircraft. Further restrictions exist in tunnels. The faster the train moves, more progressively energy expenditure increases to overcome aerodynamic resistance until an economic feasibility limit is reached. The relations between the influence of speed on ridership volume, the magnitude of energy consumed, expenditures associated with sealed rolling stock and their worth in relation to the total length of tunnels, as well as energy needed to cool tunnels of subcritical cross sectional areas determine the actual operational speed on high-speed rail lines worldwide. EN 14067 – Railway Aerodynamics gives guidance on recommended methods of analyses and testing.

#### **3.1.3.1 Free Air Train Resistance on Level Track**

Any aerodynamic consideration starts with a free air train resistance equation that constitutes a basic performance parameter and aerodynamic signature of a particular train. This equation consists of a constant representing train resistance independent of speed, a linear member representing train resistance proportional to speed such as the effect of rolling friction, and a quadratic member representing aerodynamic resistance. This member is expressed as a drag coefficient in free air reflecting the dynamic properties of the shape and size of the train multiplied by the square of speed.

The train resistance may be expressed in deca-Newtons [daN] per train, as a unit train resistance in [daN] per ton, or in kN if the mass of the train is known. It can be further expressed as power in mega watts [MW].

#### **3.1.3.2 Steady State Aerodynamics in High-Speed Rail Tunnels**

The steady state aerodynamics represents air as an incompressible fluid which is a permissible assumption at high-speeds (Lancien, Caille, Jutard, Parent de Cruzon, 1987). It is descriptive of a state that eventually develops after a train travels through a tunnel for a time period that is sufficient to establish a permanent fluid flow regimen. It is characteristic of long tunnels; however indications of steady state forming exist in tunnels of any lengths. The steady state aerodynamic analyses provide primarily basic information on energy demand and its thermal conversion.

The free air train resistance equation of a high-speed train is modified by substituting the drag coefficient in tunnel for its drag coefficient in free air to arrive at an equation for train resistance in tunnels. The drag coefficient in tunnel consists of the free air drag coefficient enlarged by an increment, a mathematical function that includes the effect of Blockage Ratio, tunnel length and frictional conditions in the tunnel expressed by separate coefficients.



The air in long tunnels is pushed in the direction opposite to the movement of the train increasing the friction between the virtual layers of air. Also, the pressure differential between the train's front and rear further increases the friction and associated aerodynamic resistance. This differential often controls the train design and comfort criteria.

The energy necessary to overcome the aerodynamic resistance in long tunnels eventually converts to kinetic energy of air, turbulence and heat. When an undersized cross section of a tunnel is used, the air in a tunnel must be cooled to avoid problems associated with elevated temperatures and to ensure survivable tunnel environment in a case of emergency evacuation. The total power expenditure can reach the double of the traction demand of the train. The power is supplied to the train to overcome aerodynamic resistance while moving through the tunnel, and additionally, the power is supplied to cooling system to remove a major part of the aerodynamic traction contingent converted to heat.

The critical cross section of a long tunnel is thus defined as the smallest cross section that can be used without a cooling system to comply with applicable tunnel safety codes.

The described basic train resistance equation for tunnels constitutes only a part of steady state aerodynamic analyses. These include also prediction of pressure conditions in tunnels at various locations along the train and at various locations within the tunnel, as well as associated individual air flow speeds that are constant in the steady state regimen, and various secondary aerodynamic effects including turbulences.

#### 3.1.4 Temperature

Electrical power used by trains in overcoming aerodynamic and rolling resistances degrades into heat. Within a tunnel environment, this is supplemented by heat from power losses, train air conditioning systems and tunnel services. On the Channel Tunnel, studies showed that in ultimate traffic conditions, the average level of heat generated would be 80 MW with only 10 MW conducted away through rock strata and tunnel ventilation. A cooling system was developed which removed heat from the tunnel to keep air temperatures below 25°C (77°F). Without cooling, temperatures inside tunnels could reach 50°C (122°F) after several months of operation. Water chilled to 3°C (37°F) was circulated through 2 x 400 m (1315 ft) pipes mounted to the marine running tunnel walls. Maintaining temperatures below 20°C (68°F) in the Channel Tunnel, at which no train air conditioning would be required, was considered to be impractical.

Once the aerodynamic drag and power requirements on design gradients have been calculated, the optimum operating air temperature must be established and the measures to reduce the air temperature from its heated state due to operation of the trains to the optimum temperature established. These measures can be adopted within the established free cross sectional area as space is available to include chiller pipes in the running tunnels. Associated cooling equipment will be located in niches or shafts.

There may be alternative means to cool the tunnels such as continuous ventilation and a cost benefit analysis will be carried out during the subsequent design phases.

#### 3.1.5 Sonic Booms at Tunnel Portals

Transient air pressures which are not reflected back along the tunnel exit the tunnel portal as a sonic boom of a similar magnitude to a gunshot.

The mitigation measures for sonic booms are as follows:

- Rolling Stock – elongation of the train nose
- Tunnel Portal Entrance – trumpet or flared tunnel entrance hoods, short shafts, tunnel hoods with windows, ballasted track, acoustic concrete
- Tunnel – ballasted track
- Tunnel Portal Exit – baffle chamber, porous exit, noise cancelling device

The primary issue for preliminary design is allowing sufficient space for such measures if required at the tunnel exit portals. Space requirements of 150 feet, 150% of free cross sectional area, and windows in hoods have been allowed for in tunnel portal facilities layout Directive Drawings in TM 2.4.6 Typical Tunnel Portal Facilities.



## 3.2 TUNNEL DIMENSIONS BASED ON MEDICAL HEALTH CRITERIA

A preliminary assessment of required free tunnel cross sectional area and tunnel dimensions to comply with medical health criteria has been carried out in this section. The effects of aerodynamic drag and heat buildup on tunnel dimensions are complex issues and will be addressed during a detailed assessment of tunnel dimensions.

The strength of the pressure transients depends on a large number of parameters, but is chiefly proportional to train speed, and the ratio of train cross sectional area to tunnel cross sectional area (known as the Blockage Ratio).

Procedures have been developed from extensive research and development (including wind tunnel tests and large scale experimental studies) carried out by British Rail and Deutsche Bahn AG which resulted in theoretical predictions of the pressure characteristics for a given tunnel size. These procedures were formalized in UIC Guideline 779-11R "Determination of Railway Tunnel Cross-Sectional Areas on the Basis of Aerodynamic Considerations." The UIC guideline contains data curves which give Blockage Ratios based on train cross sectional areas, train speeds and tunnel lengths. The free tunnel cross sectional area can be calculated from the Blockage Ratio and the train cross sectional area.

Neither TSI nor UIC define the shape of the tunnel, only that tunnel must be of uniform cross section. It is assumed that the guidelines apply to cut-and-cover box structures as well as bored tunnels. It is recommended that this assumption be verified using the UIC software Sealturn Version 2 or other appropriate software during a later design phase.

### 3.2.1 Calculation of Free Tunnel Cross Sectional Area

The formula for calculating the free tunnel cross sectional area for one train operation is as follows:

$$\text{Tunnel free cross sectional area} = \text{Train cross sectional area} / \text{Blockage Ratio}$$

Where:

Train cross sectional area is calculated as the projected frontal area above mid axle of the leading vehicle (see UIC 779-11 R Appendix E), and

Blockage Ratio is obtained from the limit curves in UIC 779-11 R Appendix F. Figure 2 represents ratios for a 200m long train; Figure 4 represents ratios for a 400m long train.

#### 3.2.1.1 Determination of Train Cross Sectional Area

TSI Infrastructure Section, clause 6.2.6.5 states

*"Assessment of maximum pressure variation in the tunnel (10 kPa criterion) is to be made using the results of calculations made by the Infrastructure Manager or the contracting entity on the basis of all operational conditions with all the trains complying with the High Speed Rolling Stock TSI and intended to run in the specific tunnel to be assessed.*

*The input parameters to be used are to be such that the reference characteristic pressure signature of the trains (defined in High Speed Rolling Stock TSI) is fulfilled.*

*The reference cross section areas of the interoperable trains to be considered is to be, independently to each motor or trailer vehicle:*

- 12 m<sup>2</sup> for vehicles designed for GC reference kinematic profile,
- 11 m<sup>2</sup> for vehicles designed for GB reference kinematic profile,
- 10 m<sup>2</sup> for vehicles designed for smaller kinematic profiles.

*The assessment will take into account the construction features which reduce the pressure variation (tunnel entrance shape, shafts, etc.) if any, as well as the tunnel length."*

This clause considers only TSI gauge compliant rolling stock.



Train cross-sectional areas measured from CADD drawings of the various types of high-speed rolling stock are summarized in Appendix B. Shinkansen single-level and bi-level rolling stock have the largest train cross sectional areas of the high-speed trains currently contemplated with 118 sf and 150 sf, respectively. As the Shinkansen bi-level train has the largest cross sectional area, this train was used to size the tunnels to give a conservative result. The calculations are highly sensitive to the train cross sectional area. Accordingly, calculations that are related to the cross section area of the vehicle should be verified following selection of the high-speed rolling stock.

### 3.2.1.2 Calculation of Blockage Ratio

The Blockage Ratio,  $B_{tu}$ , is determined from UIC 779-11R, Appendix F. The curves in these figures have been generated using computer software program Sealtun Version 2.

For one train operation, and a train length of 400m (1312 ft), Figure 4 of UIC 779-11 R Appendix F is used. For one train operation and a train length of 200m (660 ft) Figure 2 is used. These figures are reproduced in Appendix C.

From the curves in Appendix C the Blockage Ratio can be calculated for a given tunnel length ( $L_{tu}$ ) ranging between 0 km and 10 km (6.2 miles), and train speeds ( $V_{tr}$ ) of 330 kph (205 mph), 350 kph (220 mph) and 400 kph (250 mph).

The critical case i.e., largest required free tunnel cross sectional area is when the Blockage Ratio is smallest for a given train speed. On the curves, this critical case differs for train lengths of 200m and train lengths of 400m. For 400m trains, the critical case is between tunnel lengths of 1 km (0.6 miles) and 3.5 km (2.2 miles) for train speeds of 400 kph (250 mph), 350 kph (220 mph), and 330 kph (205 mph) respectively. For 200m trains, the critical case is for tunnel lengths of 3.5 km or less (2.2 miles or less) for train speeds of 400 kph (250 mph) and 350 kph (220 mph).

By comparison the critical case for 100 m (328 feet) trains traveling at any speed is at a tunnel length of 480 meters (0.3 miles).

For a train length of 400m (1312ft), there are no data points for tunnels of less than 1 km (0.6 miles) and more than 10 km (6.2 miles) and there are no data points on the curve for speeds of less than 330 kph (205 mph). For a train length of 200m (660ft), there are no data points for tunnels of less than 0.5 km (0.3 miles) and more than 10 km (6.2 miles) and there are no data points on the curve for speeds of less than 350 kph (220 mph). Lower speeds should be studied during a detailed assessment. However it is likely that there is a small reduction in tunnel diameter (less than 1 foot) for reduction in speed below 330 kph (205 mph).

It is recommended that a detailed assessment is carried out using UIC software program Sealtun Version 2 to get more data points for various speeds and tunnel lengths.

### 3.2.1.3 Calculation of Free Tunnel Cross Section Area

The free tunnel cross sectional areas have been calculated for the following tunnel lengths for train speeds of 400 kph (250 mph), 350 kph (220 mph) and 330 kph (205 mph) and train lengths of 200 m (660 ft) and 400m (1360 ft). These are summarized in Appendix B:

- Less than 0.6 miles (1 km)
- 0.6 miles to 2.2 miles (1 km to 3.5 km) – This represents the critical case i.e., largest required free tunnel cross sectional area.
- Greater than 2.2 miles to 3.1 miles (3.5 km to 5 km)
- Greater than 3.1 miles to 4.7 miles (5 km to 7.5 km)
- Greater than 4.7 miles to 6.2 miles (7.5 km to 10 km)
- Greater than 6.2 miles (10 km)

An allowance of 20 sf has been added to each of these free cross sectional areas to account for fixed equipment.



### 3.2.2 Tunnel Geometry

#### 3.2.2.1 Bored Tunnel

The finished bored tunnel cross sectional area is the sum of the following areas and allowances:

- Free tunnel cross sectional area as calculated above and required by the medical health criteria
- 20 sf for fixed equipment
- 6-inch allowance on diameter for construction tolerance (tunnel built too low or too small)
- 3-foot depth of invert concrete
- An escape walkway at track level (slightly raised above invert level)

These allowances have been previously described in detail in Section 2.

Drawings showing variation in tunnel diameter with speed is included in Appendix D.

Approximate finished tunnel cross sectional areas and finished tunnel diameters were calculated for the single-track circular, rectangular and the single tunnel with twin tracks and a dividing wall using these allowances (see spreadsheets in Appendix B).

The free tunnel cross section areas were measured on CAD drawings and adjusted to correspond with the calculated free cross sectional area from the spreadsheet. The adjusted finished tunnel diameters were rounded up to the nearest six inches.

Note that the finished diameter is measured to the intrados of the tunnel permanent/final liner.

Shinkansen trains are larger (wider and taller) than the AGV and TGV trains and represent the critical case. The single-level train with the largest cross sectional area is the Shinkansen 700 at 118 sf. At a speed of 220 mph, a 400m train requires a nominal 26'-6" finished tunnel diameter to comply with medical health criteria.

The bi-level train with the largest cross sectional area is the Shinkansen bi-level at 150 sf. For a single track tunnel, the Shinkansen bi-level 400m train requires an increase of 3 feet in finished tunnel diameter from 26'-6" to 29'-6" over the Shinkansen 700 single-level 400m train at a train speed of 220 mph for the critical case (tunnel lengths of 0.6 miles to 2.2 miles). This is approximately the same as the difference in height between the two trains.

For a single tunnel with twin tracks and a dividing wall, the 400m Shinkansen bi-level train requires an a finished tunnel diameter of 49'-0" at a train speed of 220 mph for the critical case (tunnel lengths of 0.6 miles to 2.2 miles). With this arrangement and a train length of 200m (660 feet) the tunnel diameter is calculated to be 47'-0" feet at a train speed of 220 mph for the critical case (tunnel lengths of 2.2 miles or less).

#### 3.2.2.2 Cut-and-Cover Tunnel

The finished cut-and-cover cross sectional area is the sum of the following areas and additional allowances:

- Free tunnel cross sectional area as calculated and required by medical health criteria.
- 20 sf for fixed equipment.
- 12 inch vertical construction tolerance (assuming slurry wall construction).
- 4 inch horizontal tolerance for soffit slab.
- Average 3'-2" feet depth of invert concrete.
- An escape walkway at track level (slightly raised above invert level).

These allowances are described in Section 2.





The structure gauge has a minimum fixed width of 21'-9". A width of 23'-9" has been assumed for the purposes of calculating tunnel heights at different design speeds. For a 400m train, these heights have been shown on the Directive Drawings for the critical case for tunnels of 0.6 miles to 2.2 miles. For a 200m train, these heights have been shown on the Directive Drawings for the critical case for tunnels of 2.2 miles or less.

The required free tunnel cross sectional areas and design speeds are tabulated on the Directive Drawings. Designers then determine an appropriate width and height to suit alignment corridor and right-of-way constraints and establish efficient structural spans for the depth of construction required.

The actual free tunnel cross-sectional area was measured and adjusted to correspond with the calculated free cross sectional area from the spreadsheet. The adjusted finished tunnel height was rounded up to the nearest 6 inches.

Drawings illustrating the variation in tunnel height with speed are included in Appendix D.

### **3.3 MITIGATION MEASURES**

Various measures that can be used to mitigate these effects, including pressure relief ducts between tunnels and airshafts. These mitigation measures will be studied further as required to ensure an efficient and optimum tunnel configuration during advanced design. The effect of these mitigation measures can be modeled with UIC software.



## 4.0 CONCLUSIONS AND RECOMMENDATIONS

Basic tunnel configurations for tunnels where high-speed trains are operating exclusively are included in Section 6. Train profile drawings prepared to enable calculation of the train cross sectional areas are included in Appendix A. Key dimensions and cross sectional areas are summarized in Appendix B. Appendix C presents the UIC Medical Health Limits Blockage Ratio curves used in the preparation free space requirements. Appendix D presents cross sections for the basic bored and cut-and-cover tunnel configurations. Appendix E (Directive Drawings to be released in the future), will present cross sections illustrating indicative fixed equipment that may be required within tunnels.

### Key findings are summarized as follows:

The choice of single-level or bi-level / duplex trains has a big influence on free tunnel cross sectional area. Using the largest train (the Shinkansen Bi-level) for the critical case of tunnel lengths of 0.6 miles to 2.2 miles, for a 1312 foot (400m) train gives the following results:

- An increase in speed from 205 mph to 220 mph requires an increase of 1'-6" in tunnel diameter, from 28'-0" to 29'-6" for a single track tunnel; 46'-0" to 49'-0" for a double track tunnel with a separating wall.
- An increase in speed from 220 mph to 250 mph requires an increase of 3'-6" feet in tunnel diameter, from 29'-6" to 33'-0" for a single track tunnel; 49'-0" to 56'-6" for a double track tunnel with a separating wall.
- A double trainset 1312 feet in length operating at 220 mph in a single track tunnel requires a 29.5-ft tunnel diameter.
- A double trainset 1312 feet in length operating at 220 mph in a twin track tunnel with separation wall requires a 49 ft tunnel diameter.

For the critical case of tunnel lengths of 2.2 miles or less, for a 660 foot (200m) train gives the following results:

- An increase in speed from 220 mph to 250 mph requires an increase of 3 feet in tunnel diameter, from 28'-6" to 31'-6" for a single track tunnel; 47'-0" to 53'-6" for a double track tunnel with a separating wall.
- A single trainset 660 feet in length operating at 220 mph in a single track tunnel requires a 28.5-ft tunnel diameter;
- A single trainset 660 feet in length operating at 220 mph in a twin track tunnel with a separating wall requires a 47-ft tunnel diameter;

It is not cost effective to design for trains speeds of 250 mph to comply with medical health criteria for train lengths of 1312 feet (400m) and tunnel lengths of 0.6 miles to 2.2 miles.

Tunnel diameters may be reduced for a train speed of 220 mph while still complying with medical health criteria for train lengths of 1312 feet (400m) and tunnels shorter than 0.6 miles and tunnels longer than 2.2 miles.

Likewise, It is not cost effective to design for train speeds of 250 mph to comply with medical health criteria for train lengths of 660 feet (200m) and tunnel lengths of 2.2 miles or less.

Tunnel diameters may be reduced for a train speed of 220 mph while still complying with medical health criteria for train lengths of 660 feet (200m) and tunnels longer than 2.2 miles,.

The mitigation measures for sonic booms are as follows:

- Rolling Stock – elongation of the train nose
- Tunnel Portal Entrance – trumpet or flared tunnel entrance hoods, short shafts, tunnel hoods with windows, ballasted track, acoustic concrete
- Tunnel – ballasted track
- Tunnel Portal Exit – baffle chamber, porous exit, noise cancelling device



The primary issue for preliminary design is allowing sufficient space for such measures if required at the tunnel exit portals. Space requirements of 150 feet, 150% of free cross sectional area, and windows in hoods have been allowed for in tunnel portal facilities layout Directive Drawings in TM 2.4.6 Typical Tunnel Portal Facilities.

Aerodynamic performance of the train, power consumption and heat generated must be considered and may represent the critical case for longer tunnels.

The following are recommended steps during subsequent phases of tunnel design

- The effect of aerodynamic drag and heat buildup on tunnel dimensions are more complex issues to resolve than medical health criteria and will be addressed during a detailed assessment of tunnel dimensions.
- As the information was derived from a variety of sources, it is recommended that the calculations related to train length and cross sectional are verified following selection of the high-speed rolling stock.
- Perform a detailed assessment of blockage rate calculation using UIC software program Sealtun Version 2 to obtain additional data points for different speeds and tunnel lengths.
- Rolling stock shall be sealed to levels equal to or exceeding those used on Shinkansen and ICE-3 trains.
- Develop case histories of comparable high-speed rail tunnels around the world including tunnel diameters, actual operating speeds, rolling stock sealing characteristics for single-track twin tunnel, passenger only high-speed operations.
- Study potential mitigation measures, including pressure relief ducts between tunnels and airshafts between the tunnels and ground surface to optimize tunnel dimensions. The effect of these mitigation measures can be modeled with UIC software.



## 5.0 SOURCE INFORMATION AND REFERENCES

1. TSI (Technical Specifications for Interoperability) for safety in Railway Tunnels in European High-Speed lines, version 20 December 2007
2. UIC Code 779-11 R, 2<sup>nd</sup> Edition, February 2005, Determination of Railway Tunnel Cross Sectional Areas on the Basis of Aerodynamic Considerations
3. GAWTHORPE R.G., Pressure Effects in Tunnels, 2000
4. THSRC Taiwan High Speed Rail Project, 2002
5. MACDONALD MOTT, The Channel Tunnel - A Designer's Perspective, 1994
6. CHSTP Technical Memorandum 2.4.2 Basic Tunnel Configuration, June 2008
7. BS EN 14067:2006 Railway Applications – Aerodynamics
8. UIC Code 660 OR, 2<sup>nd</sup> Edition, August 2002, Measures to ensure the technical compatibility of high-speed trains.
9. BOPP R, HAGENAH B, Aerodynamics, Ventilation and Tunnel Safety for High Speed rail tunnels
10. VARDY A, Generation and Alleviation of Sonic Booms from Rail Tunnels, Presentation to Institution of Civil Engineers, March 2010
11. CHSTP Technical Memorandum 1.1.10 - Structure Gauge, R0
12. CHSTP Technical Memorandum 1.1.21 - Typical Cross Sections for 15% Design, R0
13. CHSTP Technical Memorandum 3.2.6 - Traction Electrification System Requirements for Grounding and Bonding for Protection Against Electric Shock, R0
14. CHSTP Technical Memorandum 3.3.4 - Grounding and Bonding Requirements for Train Control and Communications



## 6.0 DESIGN MANUAL CRITERIA

### 6.1 BASIC TUNNEL CONFIGURATION

#### 6.1.1 General

This document establishes approximate finished dimensions for bored, mined, and cut-and-cover tunnels in which high-speed passenger trains run exclusively. The dimensions shall be used during preliminary design in determining alignment corridors and right-of-way requirements, and in the development of cost estimates.

Two basic tunnel configurations are assumed:

- Twin tunnels, with a single track in each tunnel
- A single tunnel with two tracks and a central separation wall between each track

Tunnel shapes are circular (TBM driven) for bored tunnels, arched for mined tunnels, and rectangular for cut-and-cover tunnels; all tunnels are assumed watertight.

The rolling stock is assumed to have excellent sealing characteristics.

The basic tunnel dimensions are established to comply with the European Technical Specifications for Interoperability (TSI) requirements for a 10 kPa (1.45 psi) maximum pressure variation in tunnels and underground structures for any train complying with high-speed rolling stock criteria at the maximum permitted operating speed of 220 mph. The purpose of limiting the pressure changes is to ensure no adverse health effects or discomfort to passengers and workers; these criteria are known as medical health criteria.

A preliminary assessment of the required free tunnel cross sectional areas for different train speeds and tunnel lengths were established from data provided in UIC 779-11R "Determination of railway tunnel cross sectional areas on the basis of aerodynamic considerations." Finished tunnel dimensions are established based on the required free tunnel cross sectional areas. Detailed numerical modeling is required during advanced design and recommendations for numerical modeling are provided in the UIC code.

Various measures can be used to mitigate these pressure effects, including pressure relief ducts between tunnels and airshafts between the tunnels and ground surface. These mitigation measures will be studied further as required to ensure an efficient and optimum tunnel configuration during advanced design.

Those transient air pressures which are not reflected back along the tunnel, exit the tunnel portal as a sonic boom of a similar magnitude to a gunshot. Potential mitigation measures for sonic booms are discussed in Section 6.1.5.

#### 6.1.2 Medical Health and Aural Comfort Criteria with Respect to Sealing of Rolling Stock

There are two concerns that result from these transient pressure waves and both are related to the effects of air pressure on people:

- Comfort criteria that relates to changes in pressure over time and affects people in unsealed trains, and;
- Medical health criteria that are related to instantaneous changes in pressure and may also affect people in sealed trains if there is a sudden loss of sealing.

If unsealed trains are specified, a preliminary assessment of tunnel size is obtained using the comfort criteria. If sealed trains are specified, the comfort criteria do not apply, and medical health criteria can be used to provide a preliminary assessment of required tunnel size. Note that unsealed trains (comfort criteria) require larger tunnels and/or reduced allowable speeds compared with sealed trains (medical health criteria).



### Comfort Criteria

Comfort criteria relate to rapid and significant changes of pressure across the ear drum and affect people travelling in unsealed trains. The pressure changes on an unsealed train are typically less than 4 kPa (0.58 psi) which is small compared with the 25 kPa (3.6 psi) routinely experienced on a civil aircraft. However the rate of change of pressure experienced on an unsealed train are 20 kPa to 50 kPa per second (2.9 psi to 7.25 psi per second) which is much greater than the 0.02 kPa (0.003 psi) for aircraft descent and 0.04 kPa (0.006 psi) for aircraft ascent. Even people with normal unblocked Eustachian tubes have no time to adjust by active means such as swallowing or passive means such as the automatic venting of the middle ear. Each country has different comfort criteria requirements and there are no TSI requirements for comfort criteria. The pressure comfort criteria for different countries are compared in UIC 779-11R Appendix A.

CHST rolling stock will be specified to have excellent sealing characteristics similar to Shinkansen and the ICE-3 rolling stock, and comfort criteria will not apply. Supply and maintenance of extremely well-sealed trains is a high cost item and will require careful specification and design of rolling stock.

Sealing of trains is discussed in both UIC 779-11R and UIC 660 OR – Measures to ensure the technical compatibility of high-speed trains.

The definition of sealing of trains (otherwise known as pressure tightness) is defined in UIC 779-11 Appendix F.3.  $T_{dyn}$  is expressed in seconds as the time taken for the difference between external and internal pressures to decrease from 100% to approximately 38% of the initial difference.

A summary of typical T values for different train types is given in Table 6-1.

Train type	Pressure sealing coefficient
unsealed train (e.g. regional transport)	$\tau < 0.5 \text{ s}$
poorly sealed train (e.g. Eurocity)	$0.5 \text{ s} < \tau < 6 \text{ s}$
well sealed train (e.g. ICE1, TGV)	$6 \text{ s} < \tau < 15 \text{ s}$
excellently sealed train (e.g. ICE 3, AGV)	$\tau > 15 \text{ s}$

**Table 6-1 Typical T Values based on Sealing Characteristics**

Shinkansen rolling stock is understood to have T values equal to or better than  $T = 25$  seconds. This excellently sealed rolling stock has been developed primarily due to the large percentage of tunnels by length on the Shinkansen system (tunnel length is greater than 30% of total track length) and due to the small free cross sectional area of the twin track tunnels. The Shinkansen rolling stock is continuously internally pressurized to further improve the sealing characteristics of the train. This slight internal pressurization is achieved using the air conditioning system and also prevents ingress of dust and dirt.

Testing of T values for rolling stock is defined in UIC 660 OR and consists of a full scale test involving pressurizing the interior of the carriage and measuring the drop in pressure over time.

### 6.1.3 Tunnel Cross Section

#### 6.1.3.1 Determination of Train Cross Sectional Area

The Shinkansen bi-level rolling stock has the largest train cross sectional area of the high-speed trains currently contemplated and was used to determine Blockage Ratios from the UIC guideline. It is noted that the calculation is sensitive to the train cross sectional area. Accordingly, calculations that are related to the cross section area of the vehicle should be verified following selection of the high-speed rolling stock.



### 6.1.3.2 Calculation of Blockage Ratio

The Blockage Ratio, Btu, is determined from UIC 779-11R, Appendix F.

$$\text{Tunnel free cross sectional area} = \text{Train cross sectional area} / \text{Blockage Ratio}$$

where:

Train cross sectional area is calculated as the projected frontal area above mid axle of the leading vehicle (see UIC 779-11 R Appendix E), and

The Blockage Ratio is obtained from the limit curves in UIC 779-11 R Appendix F. Figure 2 represents ratios for a 200m long train; Figure 4 represents ratios for a 400 m long train.

The curves in these figures were generated using computer software program Sealtun Version 2. For single train operation and a train length of 1312 ft (400 m), Figure 4 of UIC 779-11 R Appendix F is used. For single train operation and a train length of 660 ft (200m) Figure 2 is used.

The Blockage Ratio can be calculated for a given tunnel length (Ltu) ranging between 0.3 miles (0.5 km) and 6.2 miles (10 km), and train speeds (Vtr) of 200 mph (330 kph), 220 mph (350 kph) and 250 mph (400 kph).

The critical case, i.e., largest free tunnel cross sectional area, is when the Blockage Ratio is smallest for a given train speed. From the UIC curves for train lengths of 1312 feet (400 m), this critical case is between tunnel lengths of 0.6 miles (1 km) and 2.2 miles (10 km) for train speeds of 250 mph, 220 mph, and 200 mph, respectively. Below and above this tunnel length, the Blockage Ratio increases i.e., free tunnel cross-sectional area decreases.

For train lengths of 660 feet, this critical case is for tunnel lengths of 2.2 miles or less, for train speeds of 250 mph and 220 mph.

For comparison, the critical case for 325 ft (100 m) trains traveling at any speed is at a tunnel length of 0.3 miles, i.e., if shorter trains are used, the critical case will be at a shorter tunnel length.

### 6.1.3.3 Calculation of Free Tunnel Cross Section Area

The free tunnel cross sectional area has been calculated for the following tunnel lengths for train speeds of 250 mph, 220 mph, and 200 mph and for train lengths of 660 ft and 1360 ft.

- Less than 0.6 miles
- 0.6 miles to 2.2 miles
- Greater than 2.2 miles to 3.1 miles
- Greater than 3.1 miles to 4.7 miles
- Greater than 4.7 miles to 6.2 miles
- Greater than 6.2 miles

An allowance of 20 sf has been added to each of these free cross sectional areas to account for fixed equipment.

## 6.1.4 Tunnel Geometry

### 6.1.4.1 Bored Tunnel

The finished bored tunnel cross sectional area is the sum of the following areas and additional allowances:

- Free tunnel cross sectional area as calculated and required by the medical health criteria
- 20 sf for fixed equipment
- 6-inch allowance on diameter for construction tolerance (tunnel built too low or too small)
- 3-foot depth of invert concrete



- An escape walkway at track level (slightly raised above invert level).

For a single train of 1312 ft in length operating in a tunnel bore at a maximum speed of 220 mph, the critical case is at tunnel lengths of 0.6 miles to 2.2 miles and requires a finished tunnel diameter of 29'-6" for a single track tunnel and 49'-0" for a double track tunnel with a dividing wall. For tunnels shorter than 0.6 miles and tunnels longer than 2.2 miles, tunnel diameters can be reduced for a train speed of 220 mph while still complying with medical health criteria.

For a single train of 660 ft in length operating in a tunnel bore at a maximum speed of 220 mph, the critical case is at tunnel lengths 2.2 miles or less, and requires a finished tunnel diameter of 28'-6" for a single track tunnel and 47'-0" for a double track tunnel with a dividing wall. For tunnels longer than 2.2 miles, tunnel diameters can be reduced for a train speed of 220 mph while still complying with medical health criteria.

Aerodynamic performance of the train, power consumption and heat generated must be considered and may represent the critical case for longer tunnels.

#### 6.1.4.2 Cut-and-Cover Tunnel

The finished cut-and-cover cross sectional area is the sum of the following areas and additional allowances:

- Free tunnel cross sectional area as calculated above and required by the medical health criteria.
- 20 sf for fixed equipment.
- 12-inch vertical construction tolerance (assuming slurry wall construction).
- 4-inch horizontal tolerance for stepped invert concrete for adjustments to track grade
- Average 3'-2" depth of invert concrete.
- An escape walkway at track level (slightly raised above invert level).

The structure gauge has a minimum fixed width of 21'-9". A width of 23'-9" has been assumed for the purposes of calculating tunnel heights at different design speeds. These heights have been shown on the Directive Drawings for the critical cases for tunnel lengths of 0.6 miles to 2.2 miles for 1312 foot trains, and 2.2 miles or less for 660 foot trains.

The required free tunnel cross sectional areas and design speeds are tabulated on the Directive Drawings. Designers determine an appropriate width and height to suit alignment corridor and right-of-way constraints and determine efficient structural spans for the depth of construction required.

The actual free tunnel cross-sectional area was measured and adjusted to correspond with the calculated free cross sectional area from the spreadsheet. The adjusted finished tunnel height was rounded up to the nearest six inches.

Basic tunnel cross sections are presented in the Directive Drawings.

#### 6.1.5 Sonic Booms at Tunnel Portal Exits

Those transient air pressures which are not reflected back along the tunnel exit the tunnel portal as a sonic boom of a similar order of magnitude to a gunshot.

The mitigation measures for sonic booms are as follows:

- Rolling Stock – elongation of the train nose
- Tunnel Portal Entrance – trumpet or flared tunnel entrance hoods, short shafts, tunnel hoods with windows, ballasted track, acoustic concrete
- Tunnel – ballasted track
- Tunnel Portal Exit – baffle chamber, porous exit, noise cancelling device





The primary issue for preliminary design is allowing sufficient space for such measures if required at the tunnel exit portals. Space requirements of 150 feet, 150% of free cross sectional area, and windows in hoods have been allowed for in tunnel portal facilities layout Directive Drawings in TM 2.4.6 Typical Tunnel Portal Facilities.

## **6.1.6 Tunnel Fixed Equipment**

### **6.1.6.1 Tunnel Fixed Equipment Arrangements**

Conceptual design drawings have been developed to illustrate various types, and typical arrangement and locations of continuous and intermittent fixed equipment and the supporting tunnel structure. These drawings will be released in the future and will be subject to change as requirements for, and design of, fixed equipment is progressed. The drawings should be read in conjunction with Directive Drawings for tunnel configurations and sizes and typical cross section drawings developed for TM 1.1.21 - Typical Cross Sections. Arrangements and locations will vary at tunnel enlargements, niches, cross-passages and interfaces with other tunnel and structural sections.

### **6.1.6.2 Tunnel Clearances**

The tunnels are required to allow sufficient clearance between the various elements present in the tunnels including all necessary fixed equipment and rolling stock.

Dimensions for static and dynamic envelopes in the tunnels are the same as for other structures and development is documented in TM 1.1.10 - Structure Gauge.

The distance from the walkway envelope to the edge of the walkway has been reduced to optimize the tunnel diameter consistent with the operating assumption that personnel will not be in the tunnel outside the train during revenue operation.

The tunnel fixed equipment envelope is shown on the Directive Drawings and has been developed from the generic fixed equipment envelope shown on Directive Drawings 1.1.10-C and 1.1.10-D.

The tunnel fixed equipment gauge also encompasses the overhead catenary system electrical clearances. Further optimization of the fixed equipment gauge and other clearances may be possible once the design of the fixed equipment is complete.

The internal tunnel profile defines the tunnel structure gauge. Construction tolerances are defined separately and vary for different construction methods and structural lining types.

During design development, further consideration of seismic events will be required to optimize the clearances to and location of fixed equipment so as to mitigate potential damage to train and fixed equipment during a derailment in the tunnel.

Allowances for location specific ground movements associated with swelling ground, fault movements, landslides and other loading conditions will be determined by the designer.



## **APPENDICES**

**APPENDIX A – REPRESENTATIVE TRAIN PROFILES**

**APPENDIX B – MEDICAL HEALTH LIMITS CALCULATIONS**

**APPENDIX C – MEDICAL HEALTH LIMITS BLOCKAGE RATIO CURVES**

**APPENDIX D – DIRECTIVE DRAWINGS TM 2.4.2-A THRU F  
(BASIC TUNNEL CONFIGURATION)**

**APPENDIX E – SEE DIRECTIVE DRAWINGS (INDICATIVE TUNNEL FIXED EQUIPMENT  
ARRANGEMENTS - TO BE RELEASED IN THE FUTURE)**



7/28/2010 12:49:34 PM T:\13259B Calif High Speed Rail\CADD\Directive Drawings\2.4.2 - Basic Tunnel Configuration\2.4.2-A.dgn

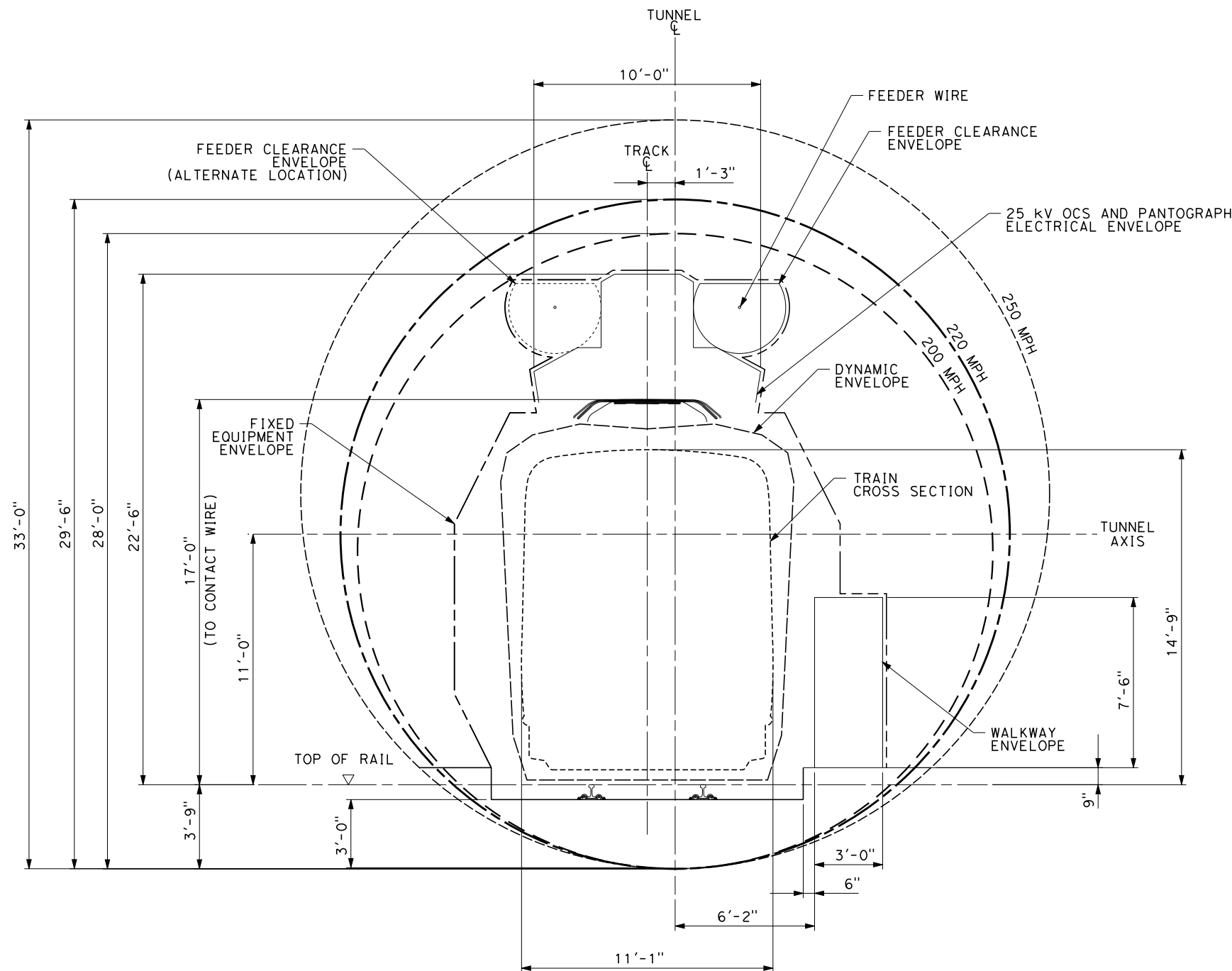

**CROSS SECTIONS FOR TUNNEL LENGTH OF 0.6 MILES TO 2.2 MILES**

**NOTES:**

1. FREE TUNNEL CROSS SECTIONAL AREAS COMPLY WITH REQUIREMENTS OF EUROPEAN TECHNICAL SPECIFICATIONS FOR INTEROPERABILITY FOR HIGH SPEED TRAINS, 2008 INFRASTRUCTURE SECTION, CLAUSE 4.2.16.1.
2. FREE TUNNEL CROSS SECTIONAL AREAS HAVE BEEN CALCULATED IN ACCORDANCE WITH MEDICAL HEALTH CRITERIA CURVES UIC GUIDELINE 779-11 R "DETERMINATION OF RAILWAY TUNNEL CROSS SECTIONAL AREAS ON THE BASIS OF AERODYNAMIC CONSIDERATIONS", APPENDIX F, FIGURE 4.
3. FREE TUNNEL CROSS SECTIONAL AREAS HAVE NOT BEEN CALCULATED TO MINIMIZE AERODYNAMIC RESISTANCE OR MINIMIZE HEAT BUILD UP IN TUNNELS.
4. FOR PANTOGRAPH DETAILS, REFER TO TM 3.2.3 PANTOGRAPH CLEARANCE ENVELOPE.
5. FOR DYNAMIC ENVELOPE DETAILS, REFER TO TM 1.1.10 STRUCTURE GAUGES.

**TABLE 1**

MINIMUM FREE TUNNEL CROSS SECTIONAL AREAS INCLUDING ALLOWANCES TO COMPLY WITH MEDICAL HEALTH CRITERIA

MINIMUM FREE TUNNEL C/S AREA (SF)	TUNNEL LENGTH (MILES)						
	< 0.6	0.6 TO 2.2	>2.2 TO 3.1	>3.1 TO 4.7	>4.7 TO 6.2	> 6.2	
DESIGN SPEED (MPH)	250	740	795	740	700	640	595
	220	595	615	585	555	555	555
	200 OR LESS	550	550	550	550	550	550

**ASSUMPTIONS FOR TABLE 1:**

1. TRAIN LENGTH OF 1312 FEET
2. SINGLE TRAIN OPERATION PER TRACK
3. TRAINS HAVE EXCELLENT SEALING CHARACTERISTICS (SHINKANSEN OR ICE 3) WITH A DYNAMIC PRESSURE TIGHTNESS COEFFICIENT  $t_{dyn} > 10$  SECONDS, WHERE T IS THE TIME TAKEN FOR THE DIFFERENCE BETWEEN EXTERNAL AND INTERNAL PRESSURES TO DECREASE FROM 100% TO APPROXIMATELY 38% OF THE INITIAL DIFFERENCE.
4. INCLUDES FIXED EQUIPMENT ALLOWANCE OF 20 SF
5. INCLUDES 6" ALLOWANCE ON DIAMETER FOR CONSTRUCTION TOLERANCE
6. AREAS ROUNDED UP TO NEAREST 5 SF

**TABLE 2**

BORED TUNNEL INTERNAL DIAMETERS EQUIVALENT TO MINIMUM FREE TUNNEL CROSS SECTIONAL AREAS INCLUDING ALLOWANCES

BORED TUNNEL INTERNAL DIAMETER (FT)	TUNNEL LENGTH (MILES)						
	< 0.6	0.6 TO 2.2	>2.2 TO 3.1	>3.1 TO 4.7	>4.7 TO 6.2	> 6.2	
DESIGN SPEED (MPH)	250	32	33	31.5	31	30	28.5
	220	28.5	29.5	28.5	28	28	28
	200 OR LESS	28	28	28	28	28	28

**ASSUMPTIONS FOR TABLE 2:**

1. DIAMETERS ROUNDED UP TO NEAREST 6 INCHES

**LEGENDS:**

- MINIMUM FREE TUNNEL CROSS SECTIONAL AREA REQUIRED (250 MPH): 795 SF
- MINIMUM FREE TUNNEL CROSS SECTIONAL AREA REQUIRED (220 MPH): 615 SF
- MINIMUM FREE TUNNEL CROSS SECTIONAL AREA REQUIRED (200 MPH): 550 SF
- TRAIN CROSS SECTIONAL AREA: 150 SF

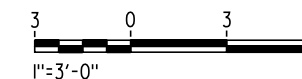

REV	DATE	BY	CHK	APP	DESCRIPTION

DESIGNED BY  
J. THOMPSON  
DRAWN BY  
D. SOLTERO  
CHECKED BY  
C. HAWKINS  
IN CHARGE  
J. CHIRCO  
DATE  
07/21/10



**CALIFORNIA HIGH-SPEED TRAIN PROJECT**

BASIC TUNNEL CONFIGURATION  
SINGLE TRACK, TBM BORED TUNNEL  
1312' LONG TRAIN

CONTRACT NO.  
13259  
DRAWING NO.  
TM 2.4.2-A  
SCALE  
AS SHOWN  
SHEET NO.

7/28/2010 12:49:53 PM T:\13259B Calif High Speed Rail\CADD\Directive Drawings\2.4.2 - Basic Tunnel Configuration\2.4.2-B.dgn

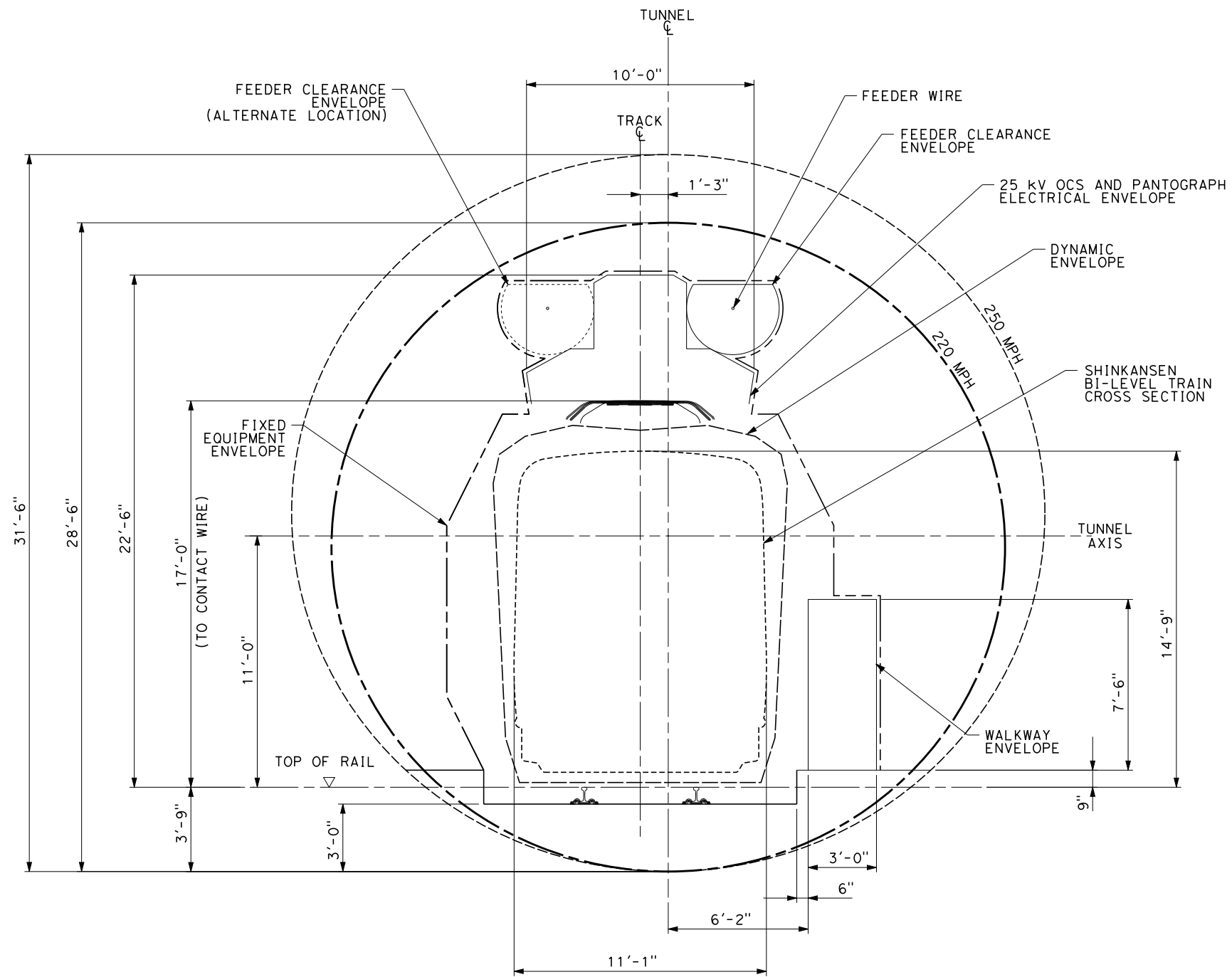

**CROSS SECTIONS FOR TUNNEL LENGTH OF 2.2 MILES OR LESS**

**NOTES:**

1. FREE TUNNEL CROSS SECTIONAL AREAS COMPLY WITH REQUIREMENTS OF EUROPEAN TECHNICAL SPECIFICATIONS FOR INTEROPERABILITY FOR HIGH SPEED TRAINS, 2008 INFRASTRUCTURE SECTION, CLAUSE 4.2.16.1.
2. FREE TUNNEL CROSS SECTIONAL AREAS HAVE BEEN CALCULATED IN ACCORDANCE WITH MEDICAL HEALTH CRITERIA CURVES UIC GUIDELINE 779-11 R "DETERMINATION OF RAILWAY TUNNEL CROSS SECTIONAL AREAS ON THE BASIS OF AERODYNAMIC CONSIDERATIONS", APPENDIX F, FIGURE 2.
3. FREE TUNNEL CROSS SECTIONAL AREAS HAVE NOT BEEN CALCULATED TO MINIMIZE AERODYNAMIC RESISTANCE OR MINIMIZE HEAT BUILD UP IN TUNNELS.
4. FOR PANTOGRAPH DETAILS, REFER TO TM 3.2.3 PANTOGRAPH CLEARANCE ENVELOPE.
5. FOR DYNAMIC ENVELOPE DETAILS, REFER TO TM 1.1.10 STRUCTURE GAUGES.

**TABLE 1**

MINIMUM FREE TUNNEL CROSS SECTIONAL AREAS INCLUDING ALLOWANCES TO COMPLY WITH MEDICAL HEALTH CRITERIA

MINIMUM FREE TUNNEL C/S AREA (SF)	TUNNEL LENGTH (MILES)						
	< 0.6	0.6 TO 2.2	>2.2 TO 3.1	>3.1 TO 4.7	>4.7 TO 6.2	> 6.2	
DESIGN SPEED (MPH)	250	725	725	680	650	605	565
	220	580	575	545	545	545	545
	200 OR LESS	N/D	N/D	N/D	N/D	N/D	N/D

**ASSUMPTIONS FOR TABLE 1:**

1. TRAIN LENGTH OF 660 FEET
2. SINGLE TRAIN OPERATION PER TRACK
3. TRAINS HAVE EXCELLENT SEALING CHARACTERISTICS (SHINKANSEN OR ICE 3) WITH A DYNAMIC PRESSURE TIGHTNESS COEFFICIENT,  $T_{dyn} > 10$  SECONDS, WHERE T IS THE TIME TAKEN FOR THE DIFFERENCE BETWEEN EXTERNAL AND INTERNAL PRESSURES TO DECREASE FROM 100% TO APPROXIMATELY 38% OF THE INITIAL DIFFERENCE.
4. INCLUDES FIXED EQUIPMENT ALLOWANCE OF 20 SF
5. INCLUDES 6" ALLOWANCE ON DIAMETER FOR CONSTRUCTION TOLERANCE
6. AREAS ROUNDED UP TO NEAREST 5 SF

**TABLE 2**

BORED TUNNEL INTERNAL DIAMETERS EQUIVALENT TO MINIMUM FREE TUNNEL CROSS SECTIONAL AREAS INCLUDING ALLOWANCES

BORED TUNNEL INTERNAL DIAMETER (FT)	TUNNEL LENGTH (MILES)						
	< 0.6	0.6 TO 2.2	>2.2 TO 3.1	>3.1 TO 4.7	>4.7 TO 6.2	> 6.2	
DESIGN SPEED (MPH)	250	31.5	31.5	31.0	30.0	29.0	28.5
	220	28.5	28.5	27.5	27.5	27.5	27.5
	200 OR LESS	N/D	N/D	N/D	N/D	N/D	N/D

**ASSUMPTIONS FOR TABLE 2:**

1. DIAMETERS ROUNDED UP TO NEAREST 6 INCHES

**LEGENDS:**

- MINIMUM FREE TUNNEL CROSS SECTIONAL AREA REQUIRED (250 MPH): 725 SF
- MINIMUM FREE TUNNEL CROSS SECTIONAL AREA REQUIRED (220 MPH): 575 SF
- TRAIN CROSS SECTIONAL AREA: 150 SF
- N/D NO DATA AVAILABLE IN UIC 779-11R



REV	DATE	BY	CHK	APP	DESCRIPTION

DESIGNED BY  
**C. HAWKINS**  
DRAWN BY  
**D. SOLTERO**  
CHECKED BY  
**J. THOMPSON**  
IN CHARGE  
**J. CHIRCO**  
DATE  
**07/21/10**



**CALIFORNIA HIGH-SPEED TRAIN PROJECT**

BASIC TUNNEL CONFIGURATION  
SINGLE TRACK, TBM BORED TUNNEL  
660' LONG TRAIN

CONTRACT NO.  
13259  
DRAWING NO.  
TM 2.4.2-B  
SCALE  
AS SHOWN  
SHEET NO.

7/28/2010 12:50:17 PM T:\13259B Calif High Speed Rail\CADD\Directive Drawings\2.4.2 - Basic Tunnel Configuration\2.4.2-C.dgn

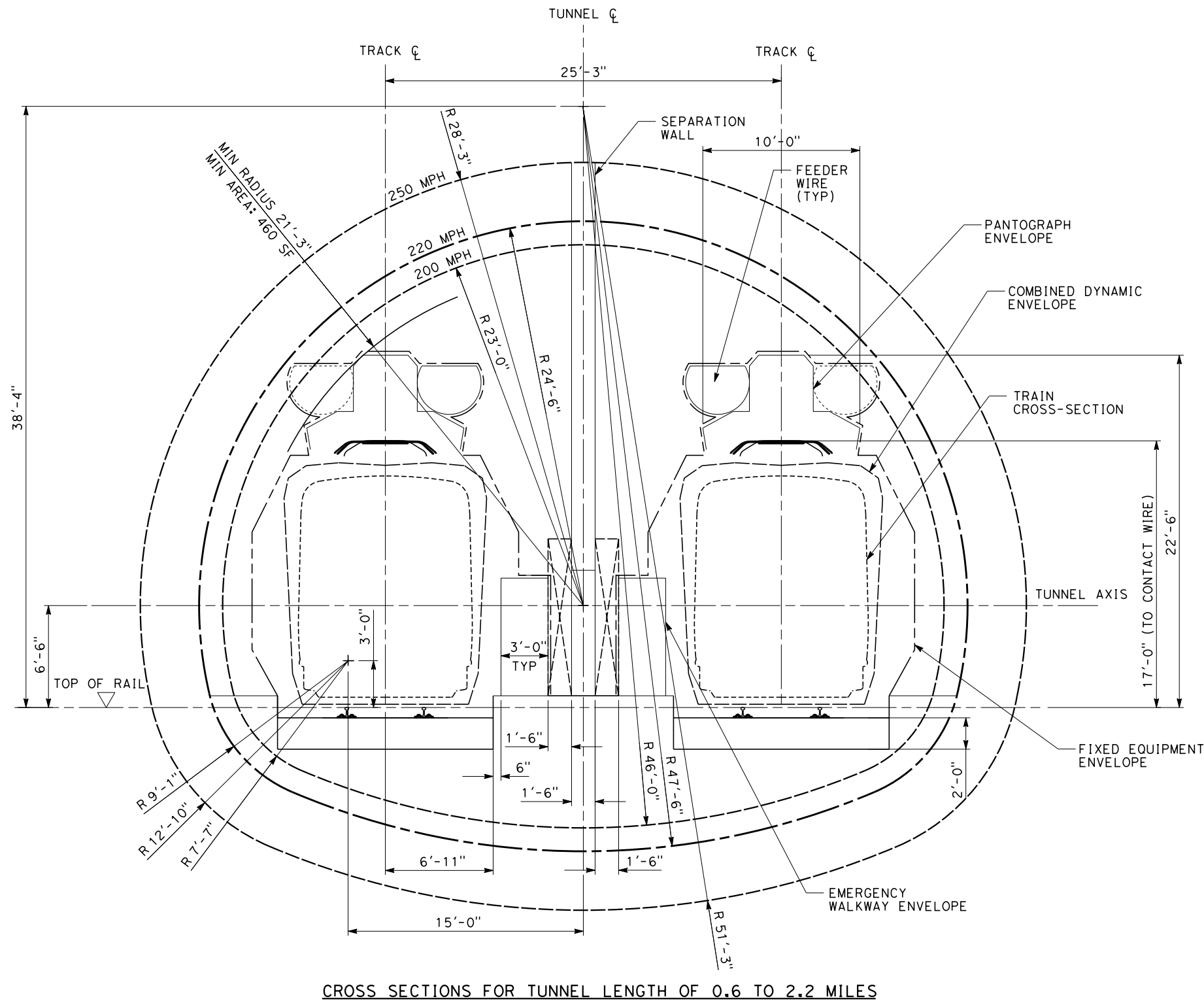

CROSS SECTIONS FOR TUNNEL LENGTH OF 0.6 TO 2.2 MILES

**NOTES:**

1. FREE TUNNEL CROSS SECTIONAL AREAS COMPLY WITH REQUIREMENTS OF EUROPEAN TECHNICAL SPECIFICATIONS FOR INTEROPERABILITY FOR HIGH SPEED TRAINS, 2008 INFRASTRUCTURE SECTION, CLAUSE 4.2.16.1.
2. FREE TUNNEL CROSS SECTIONAL AREAS HAVE BEEN CALCULATED IN ACCORDANCE WITH MEDICAL HEALTH CRITERIA CURVES UIC GUIDELINE 779-11 R "DETERMINATION OF RAILWAY TUNNEL CROSS SECTIONAL AREAS ON THE BASIS OF AERODYNAMIC CONSIDERATIONS", APPENDIX F, FIGURE 4.
3. FREE TUNNEL CROSS SECTIONAL AREAS HAVE NOT BEEN CALCULATED TO MINIMIZE AERODYNAMIC RESISTANCE OR MINIMIZE HEAT BUILD UP IN TUNNELS.
4. FOR PANTOGRAPH DETAILS, REFER TO TM 3.2.3 PANTOGRAPH CLEARANCE ENVELOPE.
5. FOR DYNAMIC ENVELOPE DETAILS, REFER TO TM 1.1.10 STRUCTURE GAUGES.

**TABLE 1**

MINIMUM FREE TUNNEL CROSS SECTIONAL AREAS INCLUDING ALLOWANCES TO COMPLY WITH MEDICAL HEALTH CRITERIA (AREA FOR ONE TRAINWAY)

MINIMUM FREE TUNNEL C/S AREA (SF)	TUNNEL LENGTH (MILES)						
	< 0.6	0.6 TO 2.2	>2.2 TO 3.1	>3.1 TO 4.7	>4.7 TO 6.2	>6.2	
DESIGN SPEED (MPH)	250	725	775	725	675	620	575
	220	575	595	565	530	530	530
	200 OR LESS	530	530	530	530	530	530

**ASSUMPTIONS FOR TABLE 1:**

1. TRAIN LENGTH OF 1312 FEET
2. SINGLE TRAIN OPERATION PER TRACK
3. TRAINS HAVE EXCELLENT SEALING CHARACTERISTICS (SHINKANSEN OR ICE 3) WITH A DYNAMIC PRESSURE TIGHTNESS COEFFICIENT,  $T_{dyn} > 10$  SECONDS, WHERE T IS THE TIME TAKEN FOR THE DIFFERENCE BETWEEN EXTERNAL AND INTERNAL PRESSURES TO DECREASE FROM 100% TO APPROXIMATELY 38% OF THE INITIAL DIFFERENCE.
4. INCLUDES FIXED EQUIPMENT ALLOWANCE OF 20 SF
5. INCLUDES 6" ALLOWANCE ON DIAMETER FOR CONSTRUCTION TOLERANCE
6. AREAS ROUNDED UP TO NEAREST 5 SF

**TABLE 2**

MINED TUNNEL INTERNAL DIAMETERS EQUIVALENT TO FREE TUNNEL CROSS SECTIONAL AREAS INCLUDING ALLOWANCES

MINED TUNNEL INTERNAL DIAMETER (FT)	TUNNEL LENGTH (MILES)						
	< 0.6	0.6 TO 2.2	>2.2 TO 3.1	>3.1 TO 4.7	>3.1 TO 4.7	>6.2	
DESIGN SPEED (MPH)	250	54.5	56.5	54.5	52.5	50.0	48.0
	220	48.0	49.0	47.5	46.0	46.0	46.0
	200 OR LESS	46.0	46.0	46.0	46.0	46.0	46.0

**ASSUMPTIONS FOR TABLE 2:**

1. DIAMETERS ROUNDED UP TO NEAREST 6 INCHES

**LEGENDS:**

- MINIMUM FREE TUNNEL CROSS SECTIONAL AREA REQUIRED (250 MPH): 775 SF
- MINIMUM FREE TUNNEL CROSS SECTIONAL AREA REQUIRED (220 MPH): 595 SF
- MINIMUM FREE TUNNEL CROSS SECTIONAL AREA REQUIRED (200 MPH): 530 SF
- TRAIN CROSS SECTIONAL AREA: 150 SF
- C/S CROSS-SECTION
- SF SQUARE FEET



REV	DATE	BY	CHK	APP	DESCRIPTION

DESIGNED BY  
C. HAWKINS  
DRAWN BY  
A. CHUENG  
CHECKED BY  
J. THOMPSON  
IN CHARGE  
J. CHIRCO  
DATE  
07/20/10

INTERNAL DRAFT



**CALIFORNIA HIGH-SPEED TRAIN PROJECT**

BASIC TUNNEL CONFIGURATION  
MINED TUNNEL WITH SEPARATION WALL  
DOUBLE TRACK, 1312' LONG TRAIN

CONTRACT NO.  
13259  
DRAWING NO.  
TM 2.4.2-C  
SCALE  
1"=4'-0"  
SHEET NO.

7/28/2010 12:50:54 PM T:\13259B Calif High Speed Rail\CADD\Directive Drawings\2.4.2 - Basic Tunnel Configuration\2.4.2-D.dgn

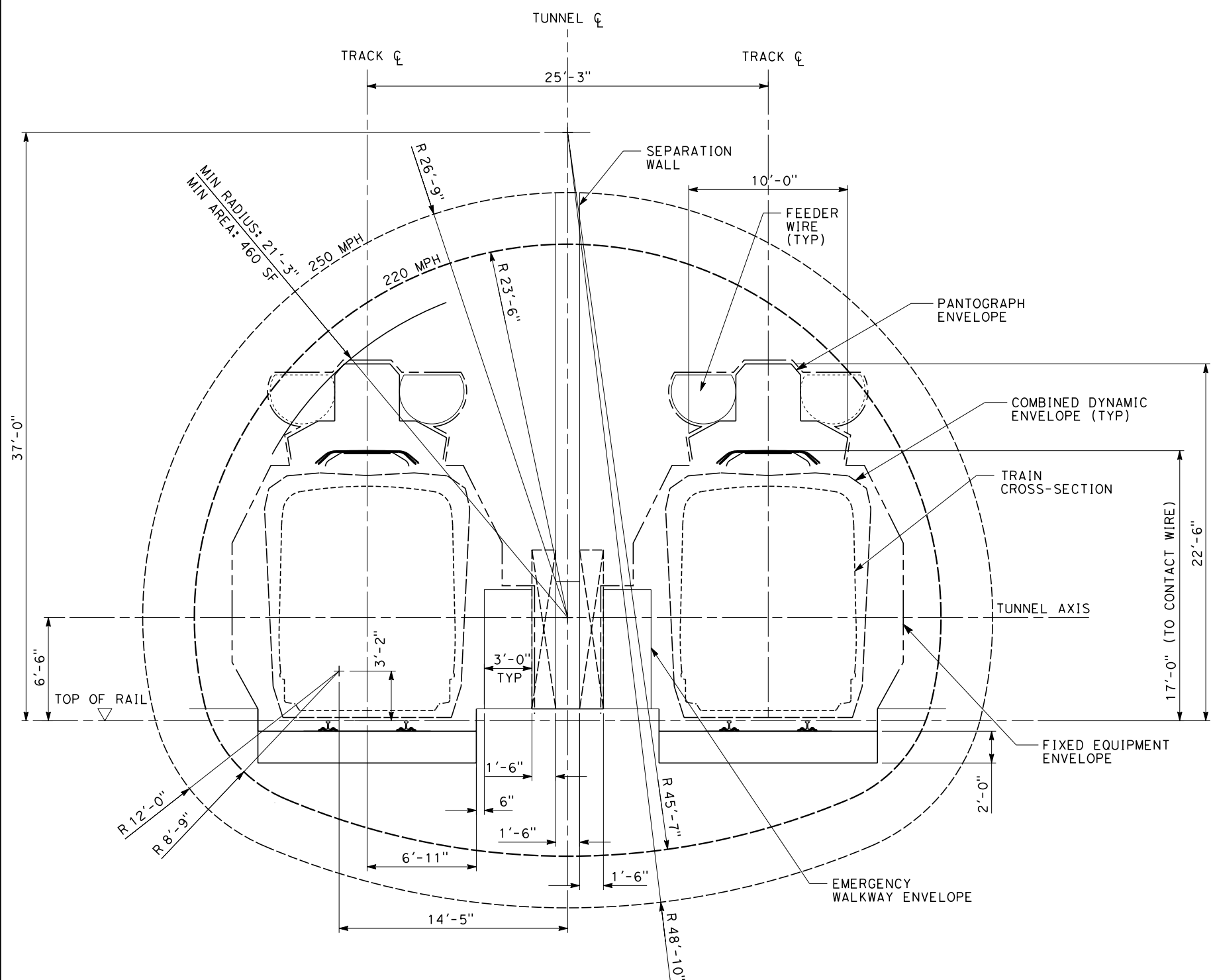

CROSS SECTION FOR TUNNEL LENGTH OF 2.2 MILES OR LESS

**NOTES:**

1. FREE TUNNEL CROSS SECTIONAL AREAS COMPLY WITH REQUIREMENTS OF EUROPEAN TECHNICAL SPECIFICATIONS FOR INTEROPERABILITY FOR HIGH SPEED TRAINS, 2008 INFRASTRUCTURE SECTION, CLAUSE 4.2.16.1.
2. FREE TUNNEL CROSS SECTIONAL AREAS HAVE BEEN CALCULATED IN ACCORDANCE WITH MEDICAL HEALTH CRITERIA CURVES UIC GUIDELINE 779-11 R "DETERMINATION OF RAILWAY TUNNEL CROSS SECTIONAL AREAS ON THE BASIS OF AERODYNAMIC CONSIDERATIONS", APPENDIX F, FIGURE 2.
3. FREE TUNNEL CROSS SECTIONAL AREAS HAVE NOT BEEN CALCULATED TO MINIMIZE AERODYNAMIC RESISTANCE OR MINIMIZE HEAT BUILD UP IN TUNNELS.
4. FOR PANTOGRAPH DETAILS, REFER TO TM 3.2.3 PANTOGRAPH CLEARANCE ENVELOPE.
5. FOR DYNAMIC ENVELOPE DETAILS, REFER TO TM 1.1.10 STRUCTURE GAUGES.

**TABLE 1**

MINIMUM FREE TUNNEL CROSS SECTIONAL AREAS INCLUDING ALLOWANCES TO COMPLY WITH MEDICAL HEALTH CRITERIA (AREA FOR ONE TRAINWAY)

MINIMUM FREE TUNNEL C/S AREA (SF)	TUNNEL LENGTH (MILES)						
	< 0.6	0.6 TO 2.2	>2.2 TO 3.1	>3.1 TO 4.7	>4.7 TO 6.2	> 6.2	
DESIGN SPEED (MPH)	250	700	665	630	585	540	
	220	545	515	515	515	515	
	200 OR LESS	N/D	N/D	N/D	N/D	N/D	

**ASSUMPTIONS FOR TABLE 1:**

1. TRAIN LENGTH OF 660 FEET
2. SINGLE TRAIN OPERATION PER TRACK
3. TRAINS HAVE EXCELLENT SEALING CHARACTERISTICS (SHINKANSEN OR ICE 3) WITH A DYNAMIC PRESSURE TIGHTNESS COEFFICIENT  $T_{DYN} > 10$  SECONDS, WHERE T IS THE TIME TAKEN FOR THE DIFFERENCE BETWEEN EXTERNAL AND INTERNAL PRESSURES TO DECREASE FROM 100% TO APPROXIMATELY 38% OF THE INITIAL DIFFERENCE.
4. INCLUDES FIXED EQUIPMENT ALLOWANCE OF 20 SF
5. INCLUDES 6" ALLOWANCE ON DIAMETER FOR CONSTRUCTION TOLERANCE
6. AREAS ROUNDED UP TO NEAREST 5 SF

**TABLE 2**

MINED TUNNEL INTERNAL DIAMETERS NEEDED TO OBTAIN MINIMUM FREE TUNNEL CROSS SECTIONAL AREAS INCLUDING ALLOWANCES

MINED TUNNEL INTERNAL DIAMETER (FT)	TUNNEL LENGTH (MILES)						
	< 0.6	0.6 TO 2.2	>2.2 TO 3.1	>3.1 TO 4.7	>4.7 TO 6.2	> 6.2	
DESIGN SPEED (MPH)	250	53.5	53.5	52.0	50.5	48.5	
	220	47.0	47.0	45.5	45.5	45.5	
	200 OR LESS	N/D	N/D	N/D	N/D	N/D	

**ASSUMPTIONS FOR TABLE 2:**

1. DIAMETERS ROUNDED UP TO NEAREST 6 INCHES

**LEGENDS:**

- MINIMUM FREE TUNNEL CROSS SECTIONAL AREA REQUIRED (250 MPH): 700 SF
- MINIMUM FREE TUNNEL CROSS SECTIONAL AREA REQUIRED (220 MPH): 545 SF
- TRAIN CROSS SECTIONAL AREA: 150 SF
- C/S CROSS SECTION
- SF SQUARE FEET
- N/D NO DATA AVAILABLE IN UIC 779-11R

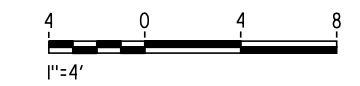

REV	DATE	BY	CHK	APP	DESCRIPTION

DESIGNED BY  
C. HAWKINS  
DRAWN BY  
D. SOLTERO  
CHECKED BY  
J. THOMPSON  
IN CHARGE  
J. CHIRCO  
DATE  
07/21/10



**CALIFORNIA HIGH-SPEED TRAIN PROJECT**

BASIC TUNNEL CONFIGURATION  
MINED TUNNEL WITH SEPARATION WALL  
DOUBLE TRACK, 660' LONG TRAIN

CONTRACT NO.  
13259  
DRAWING NO.  
TM 2.4.2-D  
SCALE  
1"=4'-0"  
SHEET NO.

7/28/2010 12:51:19 PM T:\13259B Calif High Speed Rail\CADD\Directive Drawings\2.4.2 - Basic Tunnel Configuration\2.4.2-E.dgn

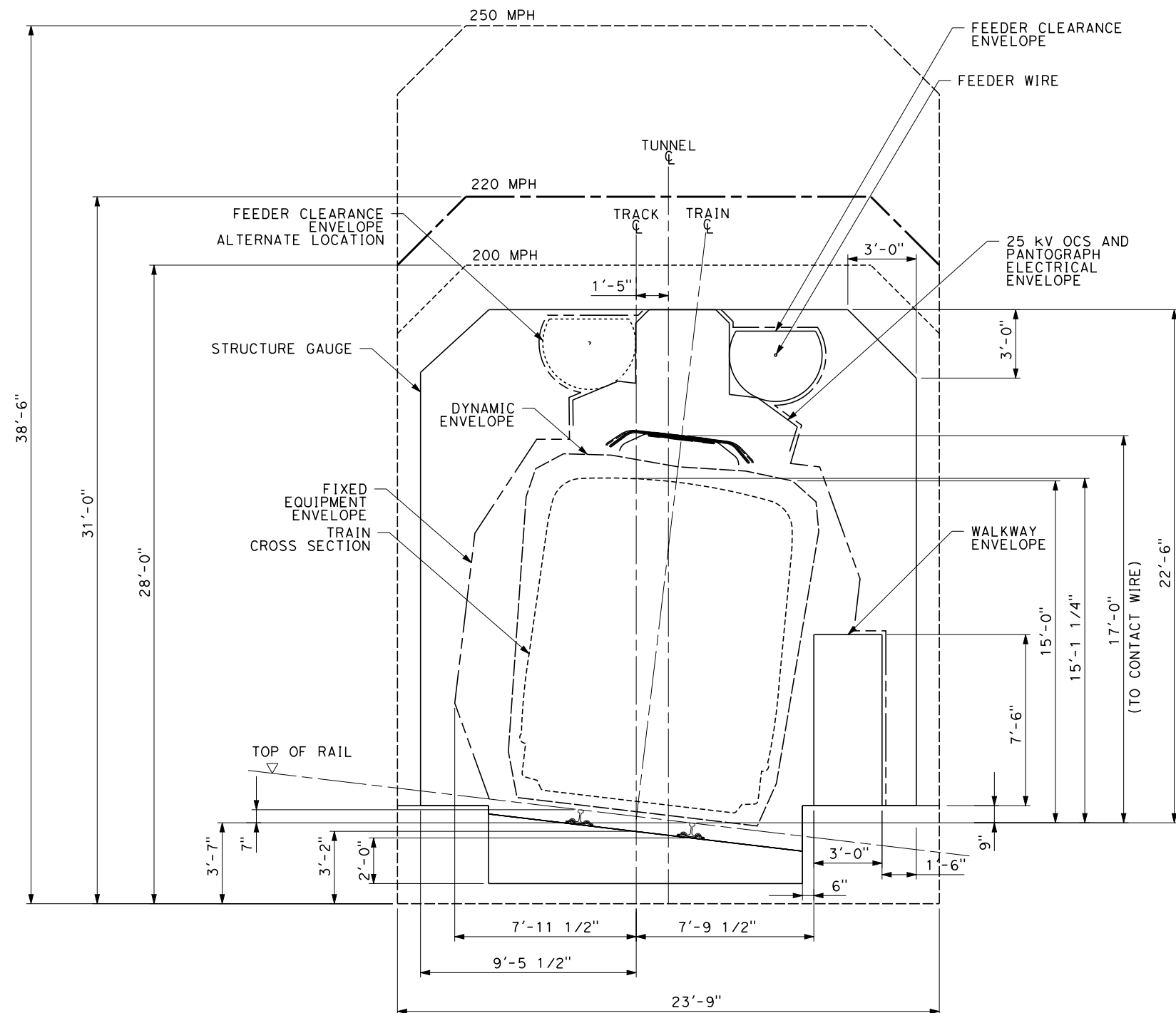

CROSS SECTIONS FOR TUNNEL LENGTH OF 0.6 MILES TO 2.2 MILES

**NOTES:**

1. FREE TUNNEL CROSS SECTIONAL AREAS COMPLY WITH REQUIREMENTS OF EUROPEAN TECHNICAL SPECIFICATIONS FOR INTEROPERABILITY FOR HIGH SPEED TRAINS, 2008 INFRASTRUCTURE SECTION, CLAUSE 4.2.16.1.
2. FREE TUNNEL CROSS SECTIONAL AREAS HAVE BEEN CALCULATED IN ACCORDANCE WITH MEDICAL HEALTH CRITERIA CURVES UIC GUIDELINE 779-11 R "DETERMINATION OF RAILWAY TUNNEL CROSS SECTIONAL AREAS ON THE BASIS OF AERODYNAMIC CONSIDERATIONS", APPENDIX F, FIGURE 4.
3. FREE TUNNEL CROSS SECTIONAL AREAS HAVE NOT BEEN CALCULATED TO MINIMIZE AERODYNAMIC RESISTANCE OR MINIMIZE HEAT BUILD UP IN TUNNELS.
4. FOR PANTOGRAPH DETAILS, REFER TO TM 3.2.3 PANTOGRAPH CLEARANCE ENVELOPE.
5. FOR DYNAMIC ENVELOPE DETAILS, REFER TO TM 1.1.10 STRUCTURE GAUGES.

**TABLE 1**

MINIMUM FREE TUNNEL CROSS SECTIONAL AREAS INCLUDING ALLOWANCES TO COMPLY WITH MEDICAL HEALTH CRITERIA

MINIMUM FREE TUNNEL C/S AREA (SF)	TUNNEL LENGTH (MILES)						
	< 0.6	0.6 TO 2.2	>2.2 TO 3.1	>3.1 TO 4.7	>4.7 TO 6.2	> 6.2	
DESIGN SPEED (MPH)	250	755	810	755	715	655	610
	220	610	630	600	570	570	570
	200 OR LESS	560	560	560	560	560	560

**ASSUMPTIONS FOR TABLE 1:**

1. TRAIN LENGTH OF 1312 FEET
2. SINGLE TRAIN OPERATION PER TRACK
3. TRAINS HAVE EXCELLENT SEALING CHARACTERISTICS (SHINKANSEN OR ICE 3) WITH A DYNAMIC PRESSURE TIGHTNESS COEFFICIENT  $T_{dyn} > 10$  SECONDS, WHERE T IS THE TIME TAKEN FOR THE DIFFERENCE BETWEEN EXTERNAL AND INTERNAL PRESSURES TO DECREASE FROM 100% TO APPROXIMATELY 38% OF THE INITIAL DIFFERENCE.
4. INCLUDES FIXED EQUIPMENT ALLOWANCE OF 20 SF
5. INCLUDES 6" ALLOWANCE ON EACH VERTICAL WALL AND 3" ALLOWANCE ON SOFFIT FOR CONSTRUCTION TOLERANCE
6. AREAS ROUNDED UP TO NEAREST 5 SF

**TABLE 2**

CUT AND COVER TUNNEL INTERNAL HEIGHTS EQUIVALENT TO MINIMUM FREE TUNNEL CROSS SECTIONAL AREAS INCLUDING ALLOWANCES

CUT-AND-COVER TUNNEL INTERNAL HEIGHT (FT) (WIDTH FIXED AT 23.75 FT)	TUNNEL LENGTH (MILES)						
	< 0.6	0.6 TO 2.2	>2.2 TO 3.1	>3.1 TO 4.7	>4.7 TO 6.2	> 6.2	
DESIGN SPEED (MPH)	250	36	38.5	36	34.5	32	30
	220	30	31	29.5	28.5	28.5	28.5
	200 OR LESS	28	28	28	28	28	28

**ASSUMPTIONS FOR TABLE 2:**

1. HEIGHTS ROUNDED UP TO NEAREST 6 INCHES

**LEGENDS:**

- MINIMUM FREE TUNNEL CROSS SECTIONAL AREA (250 MPH): 810 SF
- MINIMUM FREE TUNNEL CROSS SECTIONAL AREA (220 MPH): 630 SF
- MINIMUM FREE TUNNEL CROSS SECTIONAL AREA (200 MPH): 560 SF
- TRAIN CROSS SECTIONAL AREA: 150 SF

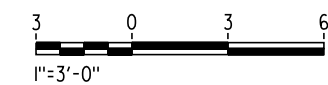

REV	DATE	BY	CHK	APP	DESCRIPTION

DESIGNED BY  
J. THOMPSON  
DRAWN BY  
P. DO  
CHECKED BY  
C. HAWKINS  
IN CHARGE  
J. CHIRCO  
DATE  
07/21/10



**CALIFORNIA HIGH-SPEED TRAIN PROJECT**

BASIC TUNNEL CONFIGURATION  
CUT-AND-COVER TUNNEL  
SINGLE AND DOUBLE TRACK, 1312' LONG TRAIN

CONTRACT NO.  
13259  
DRAWING NO.  
TM 2.4.2-E  
SCALE  
AS SHOWN  
SHEET NO.

7/28/2010 12:51:47 PM T:\13259B Calif High Speed Rail\CADD\Directive Drawings\2.4.2 - Basic Tunnel Configuration\2.4.2-F.dgn

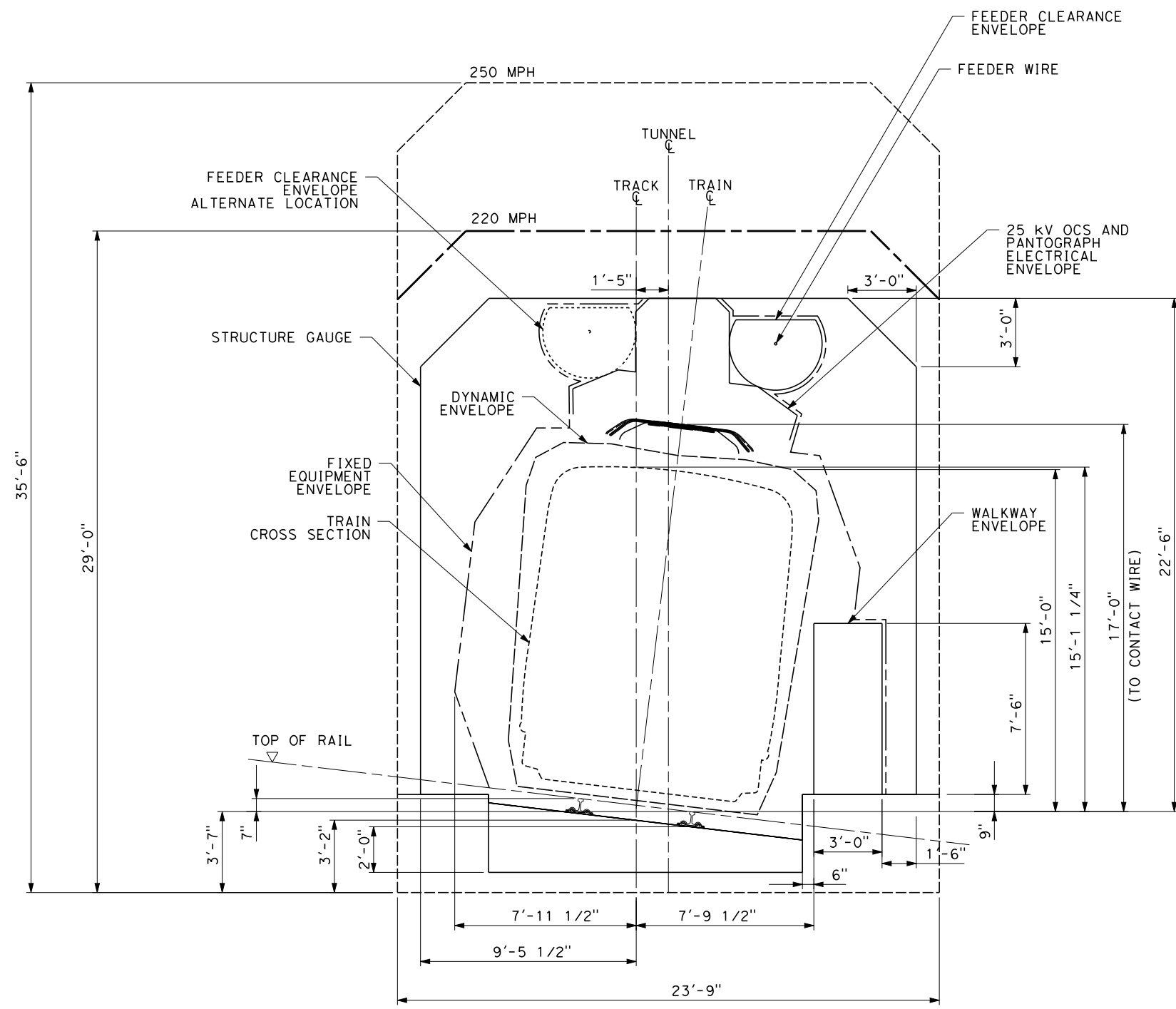

CROSS SECTIONS FOR TUNNEL LENGTH OF 2.2 MILES OR LESS

**NOTES:**

1. FREE TUNNEL CROSS SECTIONAL AREAS COMPLY WITH REQUIREMENTS OF EUROPEAN TECHNICAL SPECIFICATIONS FOR INTEROPERABILITY FOR HIGH SPEED TRAINS, 2008 INFRASTRUCTURE SECTION, CLAUSE 4.2.16.1.
2. FREE TUNNEL CROSS SECTIONAL AREAS HAVE BEEN CALCULATED IN ACCORDANCE WITH MEDICAL HEALTH CRITERIA CURVES UIC GUIDELINE 779-11 R "DETERMINATION OF RAILWAY TUNNEL CROSS SECTIONAL AREAS ON THE BASIS OF AERODYNAMIC CONSIDERATIONS", APPENDIX F, FIGURE 2.
3. FREE TUNNEL CROSS SECTIONAL AREAS HAVE NOT BEEN CALCULATED TO MINIMIZE AERODYNAMIC RESISTANCE OR MINIMIZE HEAT BUILD UP IN TUNNELS.
4. FOR PANTOGRAPH DETAILS, REFER TO TM 3.2.3 PANTOGRAPH CLEARANCE ENVELOPE.
5. FOR DYNAMIC ENVELOPE DETAILS, REFER TO TM 1.1.10 STRUCTURE GAUGES.

**TABLE 1**

MINIMUM FREE TUNNEL CROSS SECTIONAL AREAS INCLUDING ALLOWANCES TO COMPLY WITH MEDICAL HEALTH CRITERIA

MINIMUM FREE TUNNEL C/S AREA (SF)	TUNNEL LENGTH (MILES)						
	< 0.6	0.6 TO 2.2	>2.2 TO 3.1	>3.1 TO 4.7	>4.7 TO 6.2	> 6.2	
DESIGN SPEED (MPH)	250	740	740	695	665	620	580
	220	595	590	560	560	560	560
	200 OR LESS	ND	ND	ND	ND	ND	ND

**ASSUMPTIONS FOR TABLE 1:**

1. TRAIN LENGTH OF 660 FEET
2. SINGLE TRAIN OPERATION PER TRACK
3. TRAINS HAVE EXCELLENT SEALING CHARACTERISTICS (SHINKANSEN OR ICE 3) WITH A DYNAMIC PRESSURE TIGHTNESS COEFFICIENT,  $T_{DYN} > 10$  SECONDS, WHERE T IS THE TIME TAKEN FOR THE DIFFERENCE BETWEEN EXTERNAL AND INTERNAL PRESSURES TO DECREASE FROM 100% TO APPROXIMATELY 38% OF THE INITIAL DIFFERENCE.
4. INCLUDES FIXED EQUIPMENT ALLOWANCE OF 20 SF
5. INCLUDES 6" ALLOWANCE ON EACH VERTICAL WALL AND 3" ALLOWANCE ON SOFFIT FOR CONSTRUCTION TOLERANCE
6. AREAS ROUNDED UP TO NEAREST 5 SF

**TABLE 2**

CUT AND COVER TUNNEL INTERNAL HEIGHTS EQUIVALENT TO MINIMUM FREE TUNNEL CROSS SECTIONAL AREAS INCLUDING ALLOWANCES

CUT-AND-COVER TUNNEL INTERNAL HEIGHT (FT) (WIDTH FIXED AT 23.75 FT)	TUNNEL LENGTH (MILES)						
	< 0.6	0.6 TO 2.2	>2.2 TO 3.1	>3.1 TO 4.7	>4.7 TO 6.2	> 6.2	
DESIGN SPEED (MPH)	250	35.5	35.5	33.5	32.0	30.5	28.5
	220	29.0	29.0	27.5	27.5	27.5	27.5
	200 OR LESS	ND	ND	ND	ND	ND	ND

**ASSUMPTIONS FOR TABLE 2:**

1. HEIGHTS ROUNDED UP TO NEAREST 6 INCHES

**LEGENDS:**

- MINIMUM FREE TUNNEL CROSS SECTIONAL AREA (250 MPH): 740 SF
- MINIMUM FREE TUNNEL CROSS SECTIONAL AREA (220 MPH): 590 SF
- TRAIN CROSS SECTIONAL AREA: 150 SF
- N/D NO DATA AVAILABLE IN UIC 779-11R

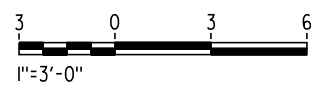

REV	DATE	BY	CHK	APP	DESCRIPTION

DESIGNED BY  
**C. HAWKINS**  
DRAWN BY  
**A. CHEUNG**  
CHECKED BY  
**J. THOMPSON**  
IN CHARGE  
**J. CHIRCO**  
DATE  
**07/22/10**



**CALIFORNIA HIGH-SPEED TRAIN PROJECT**  
  
BASIC TUNNEL CONFIGURATION  
CUT-AND-COVER TUNNEL  
SINGLE AND DOUBLE TRACK, 660' LONG TRAIN

CONTRACT NO.  
13259  
DRAWING NO.  
TM 2.4.2-F  
SCALE  
AS SHOWN  
SHEET NO.