

California High-Speed Rail Program



TECHNICAL MEMORANDUM

TYPICAL CROSS SECTIONS FOR 15% DESIGN TM 1.1.21

Prepared by: Signed document on file 19 Aug 2013
Silvia Militello Date

Checked by: Signed document on file 19 Aug 2013
Gene Lusherovich, PE Date

Approved by: Signed document on file 19 Aug 2013
John Chirco, PE, Engineering Manager Date

Released by: Signed document on file 20 Aug 2013
Teri Zink, PE, Interim Program Director Date

Revision	Date	Description
0	07 Apr 09	Initial Release, R0
1	19 Aug 13	Update to incorporate Maintenance Access and Systems Site Elements

Note: Signatures apply for the latest technical memorandum revision as noted above.

Prepared by **PARSONS
BRINCKERHOFF**
for the California High-Speed Rail Authority

This document has been prepared by **Parsons Brinckerhoff** for the California High-Speed Rail Authority and for application to the California High-Speed Rail Program. Any use of this document for purposes other than this Project, or the specific portion of the Project stated in the document, shall be at the sole risk of the user, and without liability to PB for any losses or injuries arising from such use.



System Level Technical and Integration Reviews

The purpose of the review is to provide the following:

- Technical consistency and appropriateness
- Check for integration issues and conflicts

System level reviews are required for all technical memorandums. Technical Leads for each subsystem are responsible for completing the reviews in a timely manner and identifying appropriate senior staff to perform the review. Exemption to the System Level technical and integration review by any Subsystem must be approved by the Engineering Manager.

System Level Technical Reviews by Subsystem:

Systems:	<u>Signed document on file</u> Bradley Banks, PE	<u>29 May 2013</u> Date
Infrastructure:	<u>Signed document on file</u> Gene Lusherovich, PE	<u>24 Jul 2013</u> Date
Operations and Maintenance:	<u>Signed document on file</u> Joseph Metzler	<u>29 May 2013</u> Date
Regulatory Approvals:	<u>Signed document on file</u> Vladimir Kanevskiy, PE	<u>23 Apr 2013</u> Date
Rolling Stock:	<u>Signed document on file</u> Frank Banko	<u>25 Apr 2013</u> Date

Note: Signatures apply for the latest technical memorandum revision as noted above.



TABLE OF CONTENTS

ABSTRACT 1

1.0 INTRODUCTION 2

 1.1 PURPOSE OF THE TECHNICAL MEMORANDUM 2

 1.2 STATEMENT OF TECHNICAL ISSUE 2

 1.2.1 Definition of Terms..... 2

 1.2.2 Units 5

2.0 DESIGN STANDARDS AND GUIDELINES..... 6

 2.1 GENERAL..... 6

 2.2 LAWS AND CODES 6

3.0 ASSESSMENT/ANALYSIS..... 8

 3.1 BACKGROUND 8

 3.2 CROSS SECTION ELEMENTS 8

 3.2.1 Terminology..... 8

 3.2.2 Track Centers 8

 3.2.3 Overhead Contact System Pole Location 11

 3.2.4 Walkways 11

 3.2.5 Longitudinal Drainage Considerations 13

 3.2.6 Systems Elements 14

 3.2.7 Access Control..... 14

 3.3 MAINTENANCE ACCESS 15

 3.3.1 Structures 15

 3.3.2 At-Grade..... 16

 3.3.3 Stations 16

 3.4 TYPICAL CROSS SECTIONS 16

4.0 SUMMARY AND RECOMMENDATIONS 17

5.0 SOURCE INFORMATION AND REFERENCES..... 18

6.0 DESIGN MANUAL CRITERIA 19

 6.1 15% DESIGN CROSS SECTIONS..... 19

 6.1.1 Clearances 19

 6.1.2 Track Centers 19

 6.1.3 Overhead Contact System (OCS) Poles..... 20

 6.1.4 Walkways 20

 6.1.5 Drainage Requirement..... 20

 6.1.6 Systems Elements Requirement 21

 6.1.7 Access Control..... 21

 6.1.8 Maintenance Access..... 21

APPENDIX A: TYPICAL CROSS SECTIONS FOR 15% DESIGN



ABSTRACT

Typical cross-sections for 15% Design are used to define the elements to be constructed along the high-speed train alignment, support the project-specific EIR/EIS process, assess the required right-of-way, and prepare preliminary capital cost estimates. Schematic cross sections were previously developed as part of the programmatic EIR/EIS in order to advance environmental assessment. This technical memorandum presents HST conceptual cross sections to be used in advancing the 15% alignment design to a level that supports the identification of an inclusive environmental envelope - horizontal, vertical and temporal, adequate environmental consequence analyses, permitting, coordination of utility relocation and extension, right-of-way acquisition, and promotes and supports compliance with applicable state and federal regulations. Typical cross sections with additional detail will be required to advance the project to the Preliminary Engineering for Procurement design.

Representative typical cross sections for the following high-speed rail conditions will be addressed in this document:

- Two Track Formations:
 - At-Grade
 - Aerial Trackway
 - Retained Cut / Retained Fill
 - Trench
- Two Track Formations (Tunnel Structures):
 - Cut & Cover Tunnel
 - Bored Tunnel
- Single Track Formations:
 - At-Grade
 - Aerial Trackway
- Four Track Formation (At-Grade Intermediate Station)
- Systems Sites:
 - Traction Power Facility Sites
 - Standalone Radio Sites
 - Automatic Train Control Sites

In addition, this document will define Minimum Clearances for Grade Separated Structures.

This technical memorandum uses international high-speed train system best practices in developing typical cross sections that meet the following requirements:

- Allow for uninterrupted contact between train wheels and rails. Integration of comfort criteria for passengers while limiting track deformation and air pressure variation, where required.
- Conditions required for safe operation of trains.
- Drainage of rain water.
- Promote efficient execution of earthworks and track installation.
- Control access to the operating infrastructure.
- Allow sufficient space for systems elements, pathways, and spaces.
- Allow sufficient space for maintenance of track infrastructure and systems elements in order to limit operational disruptions during inspection and light maintenance activities.



1.0 INTRODUCTION

1.1 PURPOSE OF THE TECHNICAL MEMORANDUM

The purpose of this document is to establish the elements and dimensions that define typical width of the HST cross-sections. These design elements include the following:

- Geometric characteristics of the railway track alignment and structures
- Clearance between tracks and adjacent infrastructure
- Overhead contact system poles, electrical clearances and systems elements
- Drainage systems
- Control of access
- Maintenance and inspection requirements
- Minimum clearances for grade separated structures

The intent of these typical cross sections is to provide that sufficient space for the required elements is provided in the width of high-speed train corridor defined at the 15% Design level.

This document presents the layout of system elements with standard dimensions in general cases. Particular conditions and specific situations will be identified and addressed during the 15% Design by Regional Consultants.

Note that this technical memorandum establishes the requirements for the mainline tracks in dedicated high-speed rail corridors. In corridors shared with other train operations, the design shall also consider the standards and requirements of the respective railroad owners and operators.

1.2 STATEMENT OF TECHNICAL ISSUE

This document assesses and recommends the space required for installation and maintenance of the following:

- Tracks at-grade
- Aerial trackway, tunnels, trenches and retaining walls
- OCS poles, footings and portal structures
- Traction power gantries and cabling pathways and spaces
- Automatic train control and communications equipment, cabling pathways and spaces
- Drainage facilities
- Walkways

In addition, it addresses Control of Access and includes requirements for Maintenance Access.

1.2.1 Definition of Terms

The following technical terms and acronyms used in this document have specific connotations with regard to the California High-Speed Rail Program.

<u>Cut and Fill</u>	Construction techniques involving excavation or grading followed by placement and compaction of fill material.
<u>Dedicated Corridor</u>	A segment of right-of-way within the CHSR Program where the main tracks are used exclusively for HST operations only, designated as such in the operating rules, and where these main tracks are completely separated physically from all other railroad tracks. The operation of trains (passenger and freight), other than the HST, over these tracks, is strictly prohibited in the operating rules and by regulation.
<u>Design Speed</u>	The maximum permissible speed along a segment of alignment based on the design specification of the track infrastructure, signaling system characteristics, and the maintenance specifications for that class of track.



<u>Design Standards</u>	<p>Indicate required directions for a particular design feature. Language relating to standards will typically include the word “shall”. An approved design variance is required for any deviation from the standards (see “Exceptional” below).</p> <p>The design standards presented in this document will normally be described using three terms:</p> <p>Desirable: The standard that shall be equaled or exceeded where there are no constraints on the alignment. Desirable horizontal and vertical standards may be used in any combination.</p> <p>Minimum/Maximum: The standards that shall be equaled or exceeded where constraints on alignment make Desirable standards unobtainable or significantly more expensive than Minimum/Maximum standards. Where Desirable standards are not obtainable, they shall be approached as nearly as practical.</p> <p>Exceptional: The standard that shall be achieved at the absolute minimum and only where Minimum standards are either unobtainable or exorbitantly expensive. Where Minimum standards are not obtainable, they shall be approached as nearly as practical. Approved design variances are required for the use of Exceptional standards.</p>
<u>Embankment - Fill</u>	<p>In regard to earthwork for track bed, artificial mound of imported material generally made of selected earth, gravel, or stone; built to support the HST when the reference line of the longitudinal profile is above the original ground.</p>
<u>Gantry</u>	<p>Portal frame spanning a railroad track or tracks for supporting and displaying signals, or installed parallel to the track(s) at Traction Power Facilities (TPFs) to support disconnect switches and for connecting feeder cables from the TPF to the OCS.</p>
<u>Portal Structure</u>	<p>An Overhead Contact System (OCS) structure consisting of a crossbeam or truss supported by two separate OCS poles usually placed to the outside of multiple tracks to support OCS conductors. OCS support brackets or drop pipes are attached to the beam or truss to support the OCS cantilever frames.</p>
<u>High-Speed Mainline Tracks</u>	<p>A track designated for the movement of trains at normal commercial speed having their movement protected by a control system. Tracks for the primary purpose of access to stations, yards, and other auxiliary facilities are not main tracks regardless of the presence or absence of movement protection system on those tracks. On CHST system, scheduled stops of any kind, including station stops will not normally be permitted on main tracks. On CHSR main tracks, all movements are protected by the automatic train control (ATC) system.</p>
<u>Maintenance Siding</u>	<p>A track dedicated to parking maintenance equipment and trains and normally connected to a passing track.</p>
<u>Maximum Authorized Speed</u>	<p>The highest speed that is permitted over a specific portion of the railroad. It may be authorized by special instructions of the current timetable, operating rules, or any other publication authorized by the chief operating officer.</p>
<u>OCS Pole:</u>	<p>Vertical structural element supporting the overhead contact system equipment, which provides physical support, registration and/or termination of the OCS conductors including auxiliary wires.</p>



<u>Operating Speed</u>	The highest in-service speed that is achievable by a trainset technology on a segment of alignment that conforms to all of the requirements specified for that class of track.
<u>Passing Track</u>	A designated track connected to a main track on both ends for the purpose of allowing a train to clear the main track as a part of normal operations, usually for the purpose of accessing a station platform, allowing train overtaking, or allowing trains to clear the main tracks to minimize delay in case of operational issues. For regulatory and signaling purposes the passing track is treated the same as a main track.
<u>Prepared Subgrade</u>	<p>The upper part of the subgrade is formed into a prepared subgrade layer, which normally has a cross slope.</p> <p>This layer is made of imported or treated material depending of the quality of the upper part of embankment or the bottom of the cut.</p> <p>Its quality and compactness shall be better than the material below. Its function is to minimize the deformation of the upper part of the embankment or the bottom of the cutting and to prevent water that has passed through the subballast layer from penetrating to the earthworks below.</p>
<u>Rail Shared Corridor</u>	A type of Shared Corridor in which the other transportation systems are other railroads which may include passengers and freight.
<u>Refuge Track</u>	A dead end track, normally connected to a station track, primarily for the purpose of temporary storage of a disabled train.
<u>Shared Track</u>	A track designated in the operating rules for the operation of both the high-speed trains and other passenger or freight trains. Shared Track shall have time separation between the hours of operation of the passenger or freight trains and the high-speed trains (temporal separation).
<u>Station Track / Platform Track</u>	A track for the purpose of bringing a train alongside a station platform so that a stopped train is able to embark / disembark passengers.
<u>Subballast Layer</u>	<p>An intermediate layer situated between the ballast and the subgrade layers. It protects the top of the embankment against erosion, ensures a better distribution of loads, and provides a leveled surface suitable for track laying. Subballast is made up of full crushed graduate gravel.</p> <p>This layer is also referred to as the <u>Blanket Layer</u> in the UIC standards.</p>
<u>Subgrade</u>	The top of the earthworks, on which the sub-ballast layer rests. On an embankment, the subgrade will be formed of imported soil whereas in a cut, it will be the naturally occurring soil.
<u>Superelevation</u>	The difference in elevation between the outside rail of the curve and the inside rail of the curve measured between the highest point on each rail head. Normally called Cant in European publications.
<u>Ties or Sleepers</u>	Beams placed horizontally and laid perpendicularly to the rail to hold the rails to gauge, distribute the load of the track and equipment to the underlying support, and hold the track in horizontal and vertical alignment. Ties are normally between 8 feet and 8.5 feet long, except those supporting turnouts may be up to 16 feet long. The material normally used in CHSR track will be concrete, but ties may be of wood in yard turnouts and certain other special cases.
<u>Track Bed Layers</u>	<p>General term that includes all of the new material imported for the foundation of the track. It includes the ballast and the following elements when present:</p> <ul style="list-style-type: none">• Subballast layer• Prepared subgrade



	<ul style="list-style-type: none"> • Geosynthetics
<u>Track Centerline</u>	The line equidistant between the inside faces of the rail heads of a track.
<u>Track Centers</u>	Distance between adjacent track centerlines.
<u>Track Formation Level</u>	Surface intended to receive the track bed layers.
<u>Unbalance, Unbalanced Superelevation</u>	- The difference between the Superelevation and Equilibrium Superelevation. In European publications, Unbalance is called Cant Deficiency if the actual Superelevation is less than the Equilibrium Superelevation and Excess Cant if the actual Superelevation is greater than the Equilibrium Superelevation.
<u>Upper Part of Embankment</u>	Top three feet of an embankment. It requires high quality design and construction in order to ensure the appropriate bearing-capacity to receive track bed layers.
<u>Wayside Drainage</u>	Drainage system (buried drains, ditches, precast channel drains) laid to collect and discharge surface water, seepage water, and ground water.
<u>Yard Track</u>	A section of track used for storage of trains that is auxiliary to the main track and not used by trains that are carrying passengers. Refuge tracks at stations are yard tracks. Yards consist of more than one yard track used for storing trains, inspecting trains, and accessing maintenance facilities. Yard tracks may or may not have track circuits on them.

Acronyms

AREMA	American Railway Engineering and Maintenance-of-Way Association
CFR	Code of Federal Regulations
CHSR	California High-Speed Rail
CHSRP	California High-Speed Rail Program
CPUC	California Public Utilities Commission
FRA	Federal Railroad Administration
GO	General Order
HST	High-Speed Train
SNCF	Société Nationale des Chemins de fer Français (French National Railway Company)
TSI/STI	Technical Specifications for Interoperability (European Union's)
UIC	Union Internationale des Chemins de fer (International Union of Railways – The French abbreviation is also used in English).

1.2.2 Units

The California High-Speed Rail Program is based on U.S. Customary Units consistent with guidelines prepared by the California Department of Transportation and defined by the National Institute of Standards and Technology (NIST). U.S. Customary Units are officially used in the United States, and are also known in the U.S. as “English” or “Imperial” units. In order to avoid confusion, all formal references to units of measure should be made in terms of U.S. Customary Units.



2.0 DESIGN STANDARDS AND GUIDELINES

2.1 GENERAL

The general basis for design standards is the applicable “recommended practice” described in the Manual for Railway Engineering of the American Railway Engineering and Maintenance-of-Way Association (AREMA Manual). The AREMA Manual provides guidance in the engineering of railroads moving freight at speeds of up to 70 mph and passenger trains at speeds of up to 90 mph with the exception of the still to be completed Chapter 17, High Speed Rail Systems.

However, the AREMA Manual guidance varies considerably in scope and detail from existing international high-speed train systems. Therefore, the AREMA Manual is insufficient to develop high-speed train design requirements.

Due to a lack of standards for high-speed operations in the U.S., the Authority is preparing a petition for proposed rules of particular applicability based on existing domestic or international standards as may be most appropriate or applicable to the proposed high-speed train system in California. The most common and recognized standard is the European TSI (Technical Specification for Interoperability) which defines a high-speed system based on the following subsystems and topics:

- Infrastructure
- Energy
- Control and Command
- Rolling Stock
- Maintenance
- Operations
- Safety in Tunnels

General system descriptions are informed by technical recommendation from the UIC (International Union of Railways).

2.2 LAWS AND CODES

CHSRP Design Criteria Manual presents design standards and guidelines specifically for the design, construction, and operation of high-speed railways based on international best practices. Initial high-speed rail design criteria will be issued in technical memoranda that provide guidance and procedures to advance the design of project-specific elements. Criteria for design elements not specific to HST operations will be governed by existing applicable standards, laws, and codes. Since the stations will be located within multiple municipal jurisdictions, state rights-of-way, and/or unincorporated jurisdictions, local building, planning, and zoning codes and laws are to be considered.

Applicable codes, rules, standards and guidelines may include but are not limited to:

Federal Railroad Administration (FRA) regulations, including:

- CFR Part 213, Track Safety Standards, generally and in particular, Subpart G -Train Operations at Track Classes 6 and Higher
- CFR Part 214, Railroad Workplace Safety

California Public Utilities Commission (PUC) General Orders (GO), including:

- GO 26: Clearances on Railroads and Street Railroads as to Side and Overhead Structures, Parallel Tracks and Crossings
- GO 95: Overhead Electric Line Construction. Generally and also see in particular Section VII, Detailed Construction Requirements for Trolley and Electric Railway Contact and Feeder Conductors and Their Supporting Messengers, Span Wires, etc (Class T Circuits)



- GO 118: Regulations Governing the Construction, Reconstruction, and Maintenance of Walkways Adjacent to Railroad Trackage and the Control of Vegetation Adjacent Thereto
- GO 164: Rules And Regulations Governing State Safety Oversight Of Rail Fixed Guideway Systems

The CPUC General Orders provide a significant amount of information, yet do not address HST. However, the General Orders are either applicable by law or useful as design guidelines.

Other Design Guidelines:

- The Manual for Railway Engineering of the American Railway Engineering and Maintenance-of-Way Association (AREMA Manual), in particular the following chapters:
 - Chapter 1: Roadway and Ballast
 - Chapter 5: Track
 - Chapter 17: High Speed Rail Systems
 - Chapter 28: Clearances
 - Chapter 33: Electrical Energy Utilization
- BNSF Railway: Engineering standards at:
<http://www.bnsf.com/customers/pdf/indytrkstds.pdf>
- Union Pacific Railroad: Engineering standards at:
www.uprr.com/aboutup/operations/specs/track/index.shtml
Manager of Industry and Public Projects can provide guidance to further information:
www.uprr.com/reus/roadxing/cross_cal.shtml
- Southern California Regional Rail Authority (SCRRA): Engineering standards at:
http://www.metroinktrains.com/agency/page/title/engineering_construction
- Caltrain Design Standards: Design standards at:
http://www.caltrain.com/about/doingbusiness/engineering/Engineering_Standards_and_Design_References.html
- Caltrans Manuals and Standards, including but not necessarily limited to:
 - Highway Design Manual - <http://www.dot.ca.gov/hq/oppd/hdm/hdmtoc.htm>

The most recent version of the above standards shall be applied.



3.0 ASSESSMENT/ANALYSIS

3.1 BACKGROUND

Typical cross-sections for 15% design are used to define the elements to be constructed along the high-speed train alignment, support the project-specific EIR/EIS process, assess the required right-of-way, and prepare preliminary capital cost estimates. Schematic cross sections were previously developed as part of the programmatic EIR/EIS in order to advance environmental assessment. This technical memorandum presents HST conceptual cross sections to be used in advancing the 15% Design to a level that supports the identification of an inclusive environmental envelope - horizontal, vertical and temporal, adequate environmental consequence analyses, permitting, coordination of utility relocation and extension, right-of-way acquisition, and promotes and supports compliance with applicable state and federal regulations. Typical cross sections with additional detail will be required to advance the project to the Preliminary Engineering for Procurement design.

This technical memorandum considers regulatory requirements and best practices from existing international high-speed train systems.

3.2 CROSS SECTION ELEMENTS

3.2.1 Terminology

Basic cross section terminology for track formation is shown in Figure 3.1.

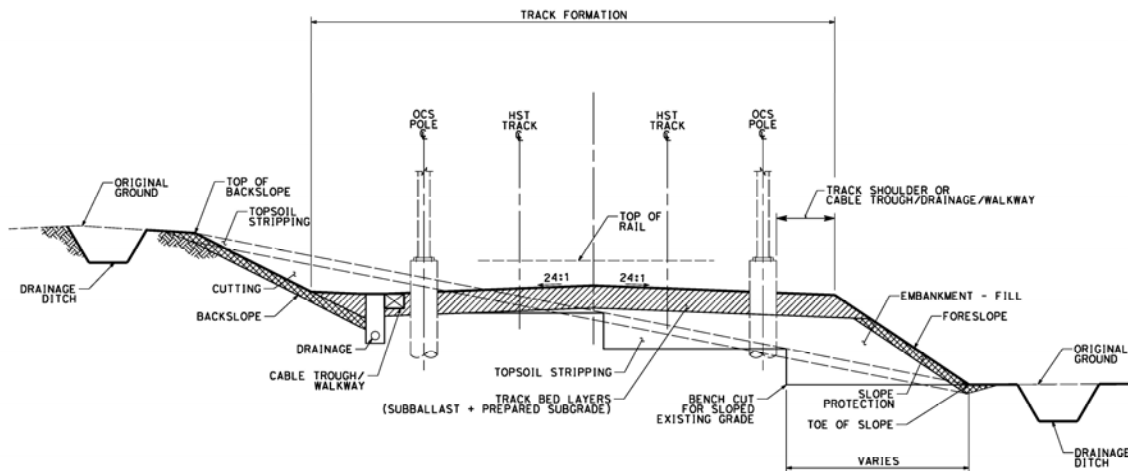

Figure 3.1 - Track Cross Section Elements

3.2.2 Track Centers

The minimum distance between track centerlines is based on the two following functional requirements:

- In all circumstances, there should not be any risk of two vehicles on separate tracks colliding. This requirement is addressed by the defined infrastructure clearance for each train on the line.
- Aerodynamic effects when train cross in opposite directions must be compatible with rolling stock design.

Railway companies that run high-speed trains develop their systems according to the rolling stock and the design speed of their respective lines. Table 3.1 presents a summary of the minimum distance between main tracks for existing HST systems.



	Line Speed				
	230 kph (143 mph)	270 kph (168 mph)	300 kph (186 mph)	350 kph (217 mph)	400 kph (250 mph)
STI (European Code for Interoperability)	13.20 ft (4.00 m)	13.80 ft (4.20 m)	13.80 ft (4.20 m)	14.80 ft (4.50 m)	
France	13.20 ft (4.00 m)	13.50 ft (4.10 m)	13.80 ft (4.20 m)	14.80 ft (4.50 m)	15.80 ft (4.80 m)
Germany			14.80 ft (4.50 m)	15.40 ft (4.70 m)	
Italy			16.40 ft (5.00 m)	16.40 ft (5.00 m)	
Spain			14.10 ft (4.30 m)	15.40 ft (4.70 m)	
Belgium		13.50 ft (4.10 m)	14.80 ft (4.50 m)		
UK	13.80 ft (4.20 m)	14.80 ft (4.50 m)	14.80 ft (4.50 m)		
Japan		14.10 ft (4.30 m)	14.10 ft (4.30 m)		
China				16.40 ft (5.00 m)	
Taiwan			14.80 ft (4.50 m)	14.80 ft (4.50m)	
South Korea				16.40 ft (5.00 m)	

Table 3.1 – Minimum Mainline Track Centers on Existing High-Speed Train Systems

CHSRP track centers shall achieve the minimum legal requirements of the California PUC and the AREMA requirements for California as summarized in Volume 4, Chapter 28 Clearances, Part 3, Table 28-3-3 and presented in Table 3.2.



CALIFORNIA	Regulation Reference			Clearance Between Track Centers							Horizontal clearance		
				Main Tracks	Any Two Subsidiary Tracks	Adjacent Subsidiary Track to Any Main Track	Ladder Track Adjacent to Any Parallel Track	Two Adjacent Parallel ladder Tracks	Lead, repair and Caboose Tracks	Team Tracks in Pairs	Unloading Tracks at Platform	General	Thru Bridges
1	2	3	4	5	6	7	8	9	10	11	18	19	20
Imperial units	G.O. 26.-D	25/01/1977	14-0	14-0	15-0	20-0	20-0	14-0	13-0	13-0	8-6	8-0	8-6
Metric Units	G.O. 26.-D	25/01/1977	4,268	4,268	4,572	6,096	6,096	4,268	3,963	3,963	2,591	2,439	2,591

CALIFORNIA	Regulation Reference			Horizontal Clearance (Continued)							
				Tunnels	Building Doors	Adjacent Subsidiary Track to Any Main Track	Platforms				
A	B	C	D				E	F			
1	2	3	21	22	23	24	25	26	27	28	29
Imperial units	G.O. 26.-D	25/01/1977	8-0	8-6	8-6	0-8	4-8			4-0	7-6 (NOTE 10)
Metric Units	G.O. 26.-D	25/01/1977	2.439	2.591	2.591	0.204	1.423			1.220	2.286 (NOTE 10)

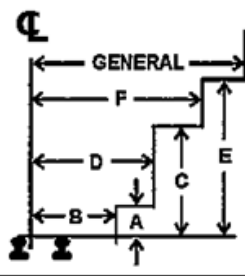

Note 10: May be 8-0 (2.439m) at 4-6 (1.372m) for refrigerator car platforms only.

CALIFORNIA	Regulation Reference			Horizontal Clearance (Continued)										
				High	Signals		Poles	Mail Cranes	Icing Docks	Ore and Cole Docks	Cattle Chutes	Wires	Pipelines	
					Low, between	Switch Boxes,								
Height	Clearance	Height	Clearance											
1	2	3	30	31	32	33	34	35	36	37	38	39	40	41
Imperial units	G.O. 26.-D	25/01/1977	8-6	3-0	6-0	0-4	3-0	8-6	6-5 (NOTE 11)	7-8	8-6	8-6	22-06 8-06	22-06 8-06
Metric Units	G.O. 26.-D	25/01/1977	2.591	0.915	1.829	0.102	0.915	2.591	1.956 (Note 11)	2.337	2.591	2.591	6.858 2.591	6.858 2.591

Note 11: To ends of arms in operating position.

Table 3.2 – Legal Clearance Requirements for California
Excerpt from AREMA Volume 4 Chapter 28 Part 3 Table 28-3-3 and 28-3-4

The proposed track centers for the California High-Speed Rail Program (CHSRP) shall meet or exceed the distance shown in Tables 3.1 and 3.2. Table 3.3 presents the Desirable, Minimum, and Exceptional values for the distance separating CHSR mainline tracks.



Design Speed		Track Centers, High-Speed Main Tracks					
		Desirable		Minimum		Exceptional	
miles per hour	km/h	feet	mm	feet	Mm	feet	mm
>125 – 250	>200 – 400	16.50	5030	16.50	5030	16.50	5030
≤ 125	≤ 200	16.50	5030	15.00	4572	14.00	4496

Table 3.3 –Distance Between Mainline Track Centers

The track center spacing for high-speed mainline tracks and passing tracks must provide adequate space for mainline drainage and overhead contact system (OCS) poles without requiring the use of expensive portal structures. If it is necessary to use portal structure to support overhead catenaries, the separation between mainline and passing track centers may be reduced, as stated below.

The French high-speed line design book indicates that a distance of 7.50 m (24.60 feet) is to be used when OCS poles are located between the tracks and that a distance of 6.50 m (21.30 feet) is to be used when there are no OCS poles between tracks.

Proposed track center separation for mainline tracks and adjacent tracks for the CHSR are shown in Table 3.4. Variation in the distance between track centers on parallel alignments shall be avoided to the extent practical.

	Desirable	Minimum
With OCS Pole	25.00 ft (7.62 m)	22.00 ft (6.71 m)
With Portal Structure	25.00 ft (7.62 m)	22.00 ft (6.71 m)

Table 3.4 – Distance Between Mainline Track Centers and Passing Track Centers

3.2.3 Overhead Contact System Pole Location

Overhead contact system (OCS) poles shall clear the dynamic envelope of the rolling stock and follow the requirement of the structure gauge. For ballasted track the poles shall be set at a distance that put the pole foundation outside of the ballast in order to ease the construction of the foundation. It is desirable that poles are not located too far away from the centerline to avoid excess stress in the pole due to the contact tension.

The distance between the centerline of the OCS pole and the centerline of the closest adjacent high-speed track shall be 10.67 feet (3.25 m).

Placing OCS poles between high-speed mainline tracks is undesirable and should be avoided.

To provide for safe clearances from OCS pole-mounted equipment, no structure more than 10 feet high above top of rail shall be constructed within 9 feet from the field-side of the centerline of the OCS pole.

3.2.4 Walkways

Unauthorized access to HST facilities and equipment shall be prevented in order to avoid injury to persons and animals, theft, damage of HST equipment, vandalism to HST property, or disruption of high-speed train operation. The entire HST right-of-way shall be protected with a fence, wall or fence-wall, fence-traffic barrier or wall-traffic barrier in combination to avoid unauthorized access by people, vehicles or animals.

The typical limits of operating infrastructure for the CHSRP are illustrated in Figure 3-2.



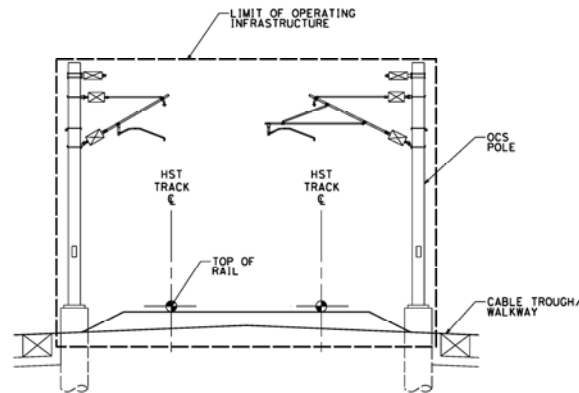

Note:

1. OCS Poles are included in the Operating Infrastructure. If OCS Poles are mounted on wall, the wall shall be included in the Operating Infrastructure.

Figure 3.2 – Limits of Operating Infrastructure

INFRASTRUCTURE ACCESS:

a) European Practices

The following are general European practices for access to high-speed train infrastructure during normal revenue service operating hours:

- Entrance in the restricted area shall be signaled to command center. Only specifically trained staff are permitted.
- Crossing tracks without specific action restricting operation through the signaling system and with confirmation of the authorization from the command center is prohibited.
- Minimum distance between the track center and the inbound edge of the walkway shall be 11.50 feet minimum in tunnel, cut-and-cover or trench with a handrail and 12.80 feet outside due to aerodynamic consideration. The minimum walkway width ranges from 2.50 feet on high-speed lines in France to 3.00 feet on CTRL (Channel Tunnel Rail Link) in the United Kingdom and 2.70 feet on the Taiwan high-speed rail system. For an Aerial Trackway and due to the presence of OCS poles at 10.67 feet from the track center, the walkway is installed on the outbound side of the OCS poles.
- Entrance into the operating infrastructure envelope, generally delimited by the OCS poles as shown on Figure 3.2, without specific action restricting operation through the signaling system and with confirmation of the authorization from the command center is prohibited.

Based on these points, the following practices are utilized:

- Foot inspection on a walkway outside of the operating infrastructure envelope is possible without a speed restriction on the closest track.
- Foot inspection on an aerial structure is subject to train speed limitations if the walkway is too close to the track (distance depends of operation speed and each country's regulations) and does not have protection against the train's wind effect.
- Inspection in underground structures beyond a certain length (length to be determined based on applicable regulations and the operating rules which are not yet developed) and in tunnels are subject to operational speed limitations.



b) Japanese (Shinkansen) Practices

Track Inspection is conducted using the following track maintenance procedures:

- Right-of-way is protected from unauthorized entry of humans/animals by fences installed along all at-grade sections.
- Train operation time periods and maintenance time periods are separated to eliminate danger for both train traffic and maintenance staff at site.
- For the safety of working staff and work efficiency, track maintenance work is conducted regularly and collectively, and during the maintenance time period at night using track maintenance machine fleet.

c) CPUC Requirements

Regulations governing the construction, reconstruction, and maintenance of walkways adjacent to railroad trackage are provided in CPUC General Order No. 118, which requires that walkways be a minimum 6.50 feet distance from the track centerline and have a minimum width of 2.00 feet.

d) CHSRP Standard

The CHSRP shall be equipped with a continuous walkway on both sides of the trackway in order to provide an egress pathway for passengers in the event of an evacuation, and access for emergency responders and maintenance personnel.

CHSRP walkways shall have a width of:

- Desirable: 3.00 feet (36 inches)
- Minimum: 3.00 feet (36 inches)
- Exceptional: 2.50 feet (30 inches)

3.2.5 Longitudinal Drainage Considerations

A high quality level of earthwork placement is required to ensure the necessary track quality to operate high-speed trains. There must not be movement of supporting track bed layers and or the underlying earthwork. To avoid risk of movement, it is necessary for all of the layers to be dry and that water ground level is far enough below the track such that there will be no influence on the track bed layers even under the vibration of operating high-speed trains. The depth of the drain, its distance from the track to obtain the right level, plus the necessity to be a safe distance from the track for maintenance, define the drainage area outside of the OCS poles where cable ducts and system equipment will be installed.

Two types of water shall be collected in order to avoid influence on the track bed layer, rain water and ground water. Even when water ground levels are low, rain water shall be evacuated from the track bed surface.

The following requirements shall be met in the cross section drainage design:

- The transversal slope on the track bed layer shall never be zero at any point in the cross section.
- In a cut, a drainage device shall be laid at cross section low points to collect water.
- Particular attention shall be taken to allow water evacuation through any longitudinal elements such as noise barriers, intrusion protection or working staff safety devices.

a) Dimensions

Maintenance of the drainage shall have a minimum disturbance to train operation. Drainage is to be set below trackbed level. This is an important element in dimensioning the drainage, mainly from the perspective of inspection and easy repair.



The drainage type shall be chosen in order of preference as follows:

1. Surface facilities such as ditches when there is no ground water to be lowered
2. Open channel when space saving is necessary or when ground water level needs to be lowered
3. A completely buried (closed) system

The minimum drainage system size is calculated based on the water volume it will need to evacuate and by monitoring and maintainability requirements. On other high-speed systems these requirements have led to a standard minimum size for drainage systems in order to allow for easy use of tools and monitoring systems.

It is common to limit maximum pipe size to 48 inches (1200 mm) in order to limit the right-of-way dimension, to ease the handling in case of maintenance, and finally to avoid as much as possible the loading area of the track.

A 24-inch (600 mm) average pipe size is recommended. According to Caltrans standard drawings, where underdrains are laid in a trench, the width of the trench is the pipe diameter plus one foot. Three (3) feet shall be provided for drainage purposes on each side of a two track formation and on one side of a single track formation.

b) Minimum distance from the OCS Pole Foundation

The drainage is typically installed in advance of the OCS pole foundations; therefore it is necessary to allow a one-foot separation between the outside limit of the OCS pole foundation and the edge of the drainage trench. This avoids damage to the drainage trench during the excavation of the OCS foundation.

The one-foot separation for construction that is added to the OCS pole foundation dimension means that the edge of the drainage trench shall not be closer than 3.00 feet from the OCS pole centerline.

3.2.6 Systems Elements

Systems elements with cross sectional space requirements include signaling, signs, posts, and cables. It will be necessary to consider signaling boxes and signaling posts for the Preliminary Engineering for Procurement design phase.

a) Train Control, Signs, Pole and Pole Footing.

This equipment is located in a 3.0-foot wide space beginning 10.20 feet from the closest track centerline, or roughly in the alignment of the OCS pole. At this design stage, it does not impact the total cross section width. The OSC pole footing is assumed to be 3.0 feet wide (36 inches) for 15% Design.

b) Cable Ductbanks/Cable Troughs/Low Voltage Manholes

Due to the quantity of cables used for signaling, communications, and powering of low voltage equipments, cable ducts shall be provided on both sides of the track formation. The cable troughs are located on the external side of the formation on the edge of the subballast layer. The width provided for cable troughs and system equipment shall be a minimum of 3.0 feet in order to allow for a sufficient number of troughs and chambers for cable connections.

c) High Voltage Cable Ductbanks/Manholes

To provide for 25kV cable installation and routing to Traction Power gantries, cable ductbanks and manholes will be required at certain Traction Power Facility site locations depending on site conditions.

3.2.7 Access Control

HST right-of-way shall have controlled access to prevent trespassing by humans and animals. Right-of-way fencing (Access Restriction (AR) Fence) shall include access gates for maintenance personnel and emergency responders. Within the vicinity of a station the right-of-way fencing



shall be installed to restrict access to the trackway. Typical right-of-way fencing is 8.0 feet high (minimum) and footing shall be located 12 inches from the HST right-of-way line and is assumed to be no less than 1.5 feet (18 inches) wide and may incorporate intrusion detection.

Access into the area of operating infrastructure may be protected with fences equipped with intrusion detection devices to alert of unauthorized entry.

3.3 MAINTENANCE ACCESS

The following are guidelines for establishing inspection and maintenance access to CHSRP infrastructure:

- Provide adequate access for the inspection, maintenance, and repair of high-speed train infrastructure.
- Where continuous longitudinal maintenance access cannot be provided to CHSRP facilities, such as aerial structures or along the retaining structures due to existing obstacles (canals, rivers, crossroads, etc.), access to the entire length of structure shall be provided from both sides of the obstruction.

These access requirements allow for inspection and routine maintenance of HSR infrastructure facilities. Major repairs of facilities due to earthquakes, accidents, or other catastrophic events may require temporary construction easements.

Per agreement with UPRR, additional right-of-way along Intrusion Barrier will be required for barrier maintenance.

Use of minimum dimensions noted below is not recommended due to potential increase of construction and maintenance costs.

3.3.1 Structures

Aerial Structures

- 15-foot (Desirable), 10-foot (Minimum) wide maintenance access measured from outside edge of structure, typically the superstructure drip line but could be column or foundation for irregular structures (i.e., straddle bents) along the length of the aerial structure.
- 15-foot (Desirable), 10-foot (Minimum) wide clearance around the columns and foundations should be maintained to provide access to the columns and the foundations.

Underground Structures

- 15-foot (Desirable), 10-foot (Minimum) wide clearance, measured from the outer edges of a bored tunnel wall for ground improvements installed during construction. This does not include temporary support that may be required during construction.
- Permanent surface and subsurface easement of 15-foot (Desirable), 5-foot (Minimum) wide for cut-and-cover tunnels shall be maintained. This does not include temporary support that may be required during construction.
- 15-foot (Desirable), 10-foot (Minimum) wide maintenance access from the outside edge of the trench wall, including evacuation structure of the trench section.

Retained Fill or Cut Structures

- 15-foot (Desirable), 10-foot (Minimum) wide maintenance access, measured from the Access Restriction (AR) fence to the face of the wall (for retained fill) or to back of the wall (for retained cut), shall be provided along retaining walls. If retaining wall is at the right-of-way and AR is on top of the wall, a 10-foot wide maintenance access easement measured from the face of the wall shall be provided.



3.3.2 At-Grade

15-foot (Desirable), 10-foot (Minimum) wide maintenance access, measured from the catch point of fill or cut slope to the right-of-way fence, shall be provided for at-grade cross sections. For cut slopes higher than 30 feet, a 20-foot maintenance access is required.

3.3.3 Stations

Access requirements around the CHST stations will be developed at a later time.

3.4 TYPICAL CROSS SECTIONS

At the preliminary design stage, conceptual cross sections of typical configurations have been developed to assist in defining the footprint of the high-speed line facilities, assessing right-of-way requirements, and determine preliminary quantities. These cross sections are developed for tangent alignments, are schematic, and are intended to define typical minimum spatial requirements, but not represent a specific design. The right-of-way required along segments of the high-speed rail alignment will depend upon actual conditions, including terrain that may require cut/fill slopes, retaining structures, and access requirements.

Typical sections for the following high-speed rail conditions are presented in Appendix A:

- Two Track Formations:
 - At-Grade
 - Aerial Trackway
 - Retained Cut / Retained Fill
 - Trench
- Two Track Formations (Tunnel Structures):
 - Cut & Cover Tunnel
 - Bored Tunnel
- Single Track Formations:
 - At-Grade
 - Aerial Trackway
- Four Track Formation (At-Grade Intermediate Station)
- Systems Sites:
 - Traction Power Facility Sites
 - Standalone Radio Sites
 - Automatic Train Control Sites



4.0 SUMMARY AND RECOMMENDATIONS

Typical cross sections for use in advancing the 15% Preliminary Design are provided in Appendix A.



5.0 SOURCE INFORMATION AND REFERENCES

1. Federal Railroad Administration Code of Federal Regulations (CFR)
2. Manual for Railway Engineering of the American Railway Engineering and Maintenance of Way Association (AREMA) Manual Volume 3, Chapter 17, High Speed Rail Systems
3. Manual for Railway Engineering of the American Railway Engineering and Maintenance of Way Association (AREMA) Manual Volume 4, Chapter 28, Clearances
4. California Public Utilities Commission General Order No. 26-D
5. California Public Utilities Commission General Order No. 118
6. Americans with Disabilities Act (ADA) Standards for Transportation Facilities
7. CHSTP Technical Memorandum 0.3 - *Basis of Design*
8. CHSTP Technical Memorandum 1.1.10 - High-Speed Equipment Structure Gauges
9. CHSTP Technical Memorandum 2.1.2 - Alignment Design Standards for High-Speed Train Operation
10. Caltrain Design Criteria (April 15, 2007)
11. TSI: Technical Specifications for Interoperability for the Trans-European Transport Network



6.0 DESIGN MANUAL CRITERIA

6.1 15% DESIGN CROSS SECTIONS

Typical high-speed rail configurations have been developed to assist in defining the general footprint of the high-speed line, assessing right-of-way requirements, and determine preliminary quantities. These cross sections are developed for tangent alignments. Note that these cross sections are schematic and are intended to define typical minimum space requirements and not a specific design. The right-of-way required along all segments of the high-speed rail alignment will depend upon actual conditions, including terrain that may require cut/fill slopes, retaining structures, intrusion protection and access requirements.

Typical sections for the following basic high-speed rail conditions are presented in Appendix A:

- Two Track Formations:
 - At-Grade
 - Aerial Trackway
 - Retained Cut / Retained Fill
 - Trench
- Two Track Formations (Tunnel Structures):
 - Cut & Cover Tunnel
 - Bored Tunnel
- Single Track Formations:
 - At-Grade
 - Aerial Trackway
- Four Track Formation (At-Grade Intermediate Station)
- Systems Sites:
 - Traction Power Facility Sites
 - Standalone Radio Sites
 - Automatic Train Control Sites

6.1.1 Clearances

See Technical Memorandum 1.1.10 High-Speed Equipment Structure Gauges.

Minimum clearances for Grade Separated Structures are noted in Appendix A – Drawing TM 1.1.21-A.

6.1.2 Track Centers

The distance between the centerlines of mainline tracks is given in Table 6.1 and is based on design speed. Variation in the distance between track centers on parallel alignments shall be avoided to the extent practical.



Design Speed	Minimum Track Centers, High-Speed Main Tracks		
	Desirable	Minimum	Exceptional
miles per hour	Feet	Feet	Feet
>125 – 250	16.50	16.50	16.50
≤ 125	16.50	15.00	14.00

Table 6.1 – Distance between Mainline Track Centers for CHSRP

The track center between a mainline track and the closest passing track is given in Table 6.2.

	Desirable	Minimum
With OCS Pole	25.00 ft (7.62 m)	22.00 ft (6.71 m)
With Portal Structure	25.00 ft (7.62 m)	22.00 ft (6.71 m)

Table 6.2 – Minimum Track Centers between Mainline and Passing Tracks

6.1.3 Overhead Contact System (OCS) Poles

The overhead contact system (OCS) poles shall clear the dynamic envelope of the rolling stock while being as close to the centerline as possible in order to avoid stress to the OCS pole due to the contact tension.

The distance between the centerline of the OCS pole and the centerline of the adjacent track shall be 10.67 feet (10 feet – 8 inches). Placing OCS poles between high-speed mainline tracks shall be avoided.

A nominal width of the OCS pole footing shall be 3.00 feet wide for 15% Preliminary Design.

To provide for safe clearances from OCS pole-mounted equipment, no structure more than 10 feet high above top of rail shall be constructed within 9 feet from the field-side of the centerline of the OCS pole.

6.1.4 Walkways

A walkway shall be provided on both sides of a high-speed railway with a two track formation and on one side of a single track formation with the inside edge of the walkway at the outside limit of the OCS pole foundation.

CHST walkways shall have a width of:

- Desirable: 3.00 feet
- Minimum: 3.00 feet
- Exceptional: 2.50 feet

6.1.5 Drainage Requirement

Open drainage (ditch): A 10-foot wide area shall be reserved on both sides of a two track and single track formation for drainage purposes.

Closed drainage (pipe culvert): A minimum culvert diameter for trunk drains located on both sides of two track and single track formations and culvert crossings under the track shall be 36 inches.

Closed drainage (underdrain): A 2-foot wide area, the edge of which is located approximately 5-feet – 6 inches (min.) from the OCS pole centerline shall be reserved on both sides of a two track formation or on one side of a single track formation for drainage purposes.



6.1.6 Systems Elements Requirement

Systems elements with cross sectional space requirements include signaling, signs, posts, and cables. It will be necessary to consider signaling boxes and signaling posts for the Preliminary Engineering for Procurement design phase.

a) Train Control, Signs, Pole and Pole Footing

This equipment is located in a 3.0-foot wide space beginning 10.20 feet from the closest track centerline, or roughly in the alignment of the OCS pole. The OSC pole footing is assumed to be 3.0 feet wide (36 inches) for 15% Design.

b) Cable Ductbanks/Cable Troughs/Low Voltage Manholes

Due to the quantity of cables used for signaling, communications, and powering of low voltage equipments, cable ducts shall be provided on both sides of the track formation. The width provided for cable troughs and system equipment shall be a minimum of 3.0 feet in order to allow for a sufficient number of troughs and chambers for cable connections.

c) High Voltage Cable Ductbanks/Manholes

To provide for 25kV cable installation and routing to Traction Power gantries, cable ductbanks and manholes will be required at certain Traction Power site locations depending on local conditions.

6.1.7 Access Control

High-speed train right-of-way shall have fully controlled access to prevent trespassing by humans and animals. Right-of-way fencing (Access Restriction (AR) Fence) shall include access gates for maintenance personnel and emergency responders. Within the vicinity of a station the right-of-way fencing shall be installed to restrict access to the trackway and to guide the passengers to the designated platform entrances. Typical right-of-way fencing is 8.0-feet high (minimum) and footing shall be located 12 inches from the HST right-of-way line and is assumed to be no less than 1.5-feet (18 inches) wide and may incorporate intrusion detection.

See Technical Memorandum 2.8.2 Access Control for High-Speed Rail Right-of-Way and Facilities.

6.1.8 Maintenance Access

The following are guidelines for establishing inspection and maintenance access to CHSTS infrastructure:

- Provide adequate access for the inspection, maintenance, and repair of high-speed train infrastructure.
- Where continuous longitudinal maintenance access cannot be provided to the CHSTP facilities, such as aerial structures or along the retaining structures due to existing obstacles (canals, rivers, crossroad, etc.), access to the entire length of structure shall be provided from both sides of the obstruction.

These access requirements allow for inspection and routine maintenance of HSR infrastructure facilities. Major repairs of facilities due to earthquakes, accidents, or other catastrophic events will require temporary construction easements.

Additional right-of-way along Intrusion Barrier will be required for barrier maintenance.

Use of minimum dimensions noted below is not recommended due to potential increase of construction and maintenance costs.



Structures

Aerial Structures

- 15-foot (Desirable), 10-foot (Minimum) wide maintenance access measured from outside edge of structure, typically the superstructure drip line but could be column or foundation for irregular structures (i.e., straddle bents) along the length of the aerial structure.
- 15-foot (Desirable), 10-foot (Minimum) wide clearance around the columns and foundations should be maintained to provide access to the columns and the foundations.

Underground Structures

- 15-foot (Desirable), 10-foot (Minimum) wide clearance, measured from the outer edges of a bored tunnel wall for ground improvements installed during construction. This does not include temporary support that may be required during construction.
- Permanent surface and subsurface easement of 15-foot (Desirable), 5-foot (Minimum) wide, for cut-and-cover tunnels shall be maintained. This does not include temporary support that may be required during construction.
- 15-foot (Desirable), 10-foot (Minimum) wide maintenance access from the outside edge of the trench wall, including evacuation structure of the trench section.

Retained Fill or Cut Structures

- 15-foot (Desirable), 10-foot (Minimum) wide maintenance access, measured from the Access Restriction (AR) fence to the face of the wall (for retained fill) or to back of the wall (for retained cut), shall be provided along the retaining walls. If retaining wall is at the right-of-way and AR is on top of the wall, a 10-foot wide maintenance access easement measured from the face of the wall shall be provided.

At-Grade

15-foot (Desirable), 10-foot (Minimum) wide maintenance access measured from the catch point of fill or cut slope to the right-of-way fence shall be provided for at-grade cross sections. For cut slopes higher than 30 feet, a 20-foot maintenance access would be required.

Stations

Access requirements around the CHST stations will be developed at a later time.



APPENDIX A - Typical Cross Sections for 15% Design

At this preliminary design stage, conceptual cross sections of typical configurations have been developed to assist in defining the general footprint of the high-speed line, assessing right-of-way requirements, and determine preliminary quantities. These cross sections are developed for tangent alignments. Note that these cross sections are schematic and are intended to define typical minimum space requirements and not a specific design. The right-of-way required along all segments of the high-speed rail alignment will depend upon actual conditions, including terrain that may require cut/fill slopes, retaining structures, and access requirements.

The following high-speed rail typical sections conditions are presented:

- Two Track Formations:
 - At-Grade
 - Aerial Trackway
 - Retained Cut / Retained Fill
 - Trench
- Two Track Formations (Tunnel Structures):
 - Cut & Cover Tunnel
 - Bored Tunnel
- Single Track Formations:
 - At-Grade
 - Aerial Trackway
- Four Track Formation (At-Grade Intermediate Station)
- Systems Sites:
 - Traction Power Facility Sites
 - Standalone Radio Sites
 - Automatic Train Control Sites



TECHNICAL MEMORANDUM (TM) DRAWING LIST	
TM 1.1.21-A	Minimum Clearance, Grade Separated Structure
TM 1.1.21-B	Two Track Formation, At-Grade, Retained-Cut, Retained-Fill, Aerial Trackway and Trench Structures
TM 1.1.21-C	Two Track Formation, Tunnel Structures
TM 1.1.21-D	Single Track Formation, At-Grade and Aerial Trackway Structures
TM 1.1.21-E	Four Track Formation, At-Grade Intermediate Station
TM 1.1.21-F	Systems Site, Traction Power Facility, At-Grade
TM 1.1.21-G	Systems Site, Traction Power Facility, Aerial
TM 1.1.21-H	Systems Site, Traction Power Facility, Trench
TM 1.1.21-I	Systems Site, Traction Power Facility, Retained -Fill 1
TM 1.1.21-J	Systems Site, Traction Power Facility, Retained-Fill 2
TM 1.1.21-K	Systems Site, Standalone Radio Site, At-Grade
TM 1.1.21-L	Systems Site, Standalone Radio Site, Aerial
TM 1.1.21-M	Systems Site, Standalone Radio Site, Trench
TM 1.1.21-N	Systems Site, Standalone Radio Site, Retained-Fill
TM 1.1.21-O	Systems Site, ATC Sites, At-Grade
TM 1.1.21-P	Systems Site, ATC Sites, Aerial
TM 1.1.21-Q	Systems Site, ATC Sites, Trench
TM 1.1.21-R	Systems Site, ATC Sites, Retained Fill



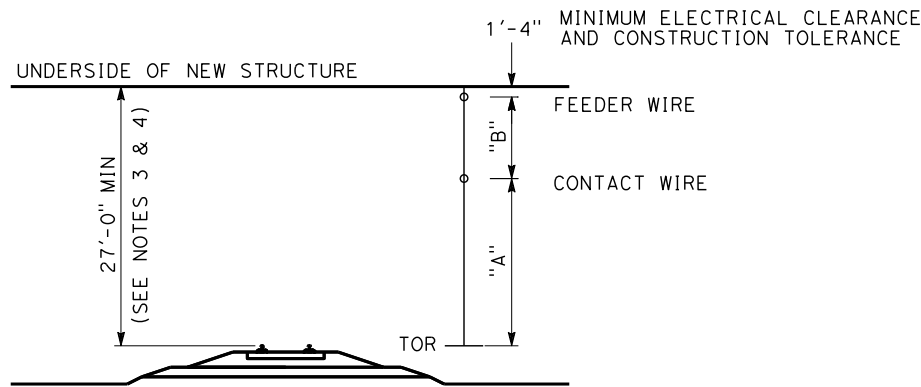

NEW STRUCTURE OVER HST TRACKS

	HEIGHT "A"	HEIGHT "B"	MIN VERTICAL CLEARANCE
DEDICATED HST TRACK	17'-5"	8'-3"	27'-0"
SHARED USE TRACK	18'-9"	6'-11"	27'-0"

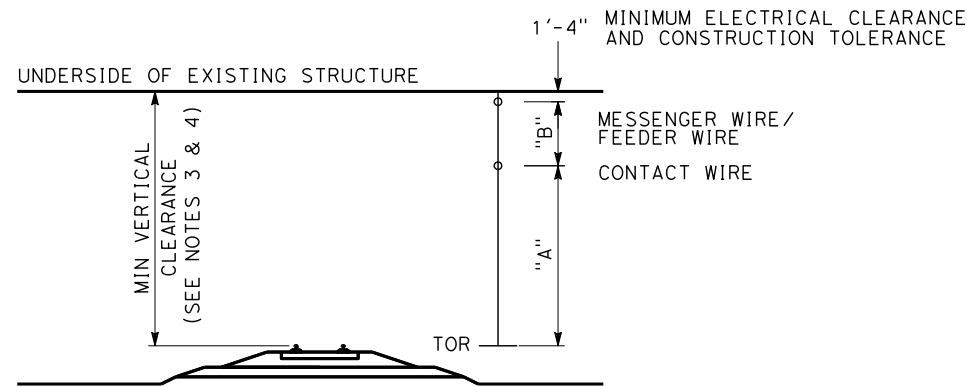

EXISTING STRUCTURE OVER HST TRACKS

	HEIGHT "A"	HEIGHT "B"	MIN VERTICAL CLEARANCE
DEDICATED HST TRACK	17'-5"	8'-3"	27'-0"
DEDICATED HST TRACK (V ≤ 125 MPH)	17'-5"	5'-3"	24'-0"*
SHARED USE TRACK	18'-9"	4'-0"	24'-6"***

* SEE NOTE 4
 *** PER CALTRAIN

NOTES:

- TOLERANCES ARE NOT ADDITIVE FOR INCREMENTAL DISTANCES.
- HST TRACKFORM IS SCHEMATIC AND DOES NOT REPRESENT THE DESIGN.
- AT LOCATIONS WHERE SUPERELEVATION IS PRESENT, VERTICAL CLEARANCES SHALL BE MEASURED FROM THE HIGH RAIL.
- DEFINED CLEARANCES ASSUMES GRADE SEPARATED STRUCTURE LENGTH ALONG TRACK IS NO MORE THAN 160 FEET FOR HST TRACK OVER 125 MPH. THE OCS SHALL BE FREE RUNNING UNDER GRADE SEPARATED STRUCTURES WITH NO SUPPORTS. STRUCTURES WIDER THAN 160 FEET REQUIRE FURTHER APPROVAL.
- PROTECTIVE PANEL IS REQUIRED FOR VERTICAL CLEARANCES LESS THAN THE PANTOGRAPH ZONE HEIGHT (26 FEET - 3 INCHES) FOR STRUCTURES OVER HST TRACKS.
- FOR LOCAL ROADWAYS, 15 FEET MINIMUM VERTICAL CLEARANCE SHALL BE CONFIRMED BY AGENCY HAVING JURISDICTION.
- PROTECTIVE STRUCTURE IS REQUIRED IF SIDE CLEARANCE IS LESS THAN 25 FEET.
- PROTECTIVE TRAFFIC BARRIER REQUIREMENTS SHALL BE CONFIRMED BY AGENCY HAVING JURISDICTION.
- SIDE CLEARANCE DESIGN CRITERIA SHALL BE CONFIRMED BY AGENCY HAVING JURISDICTION.

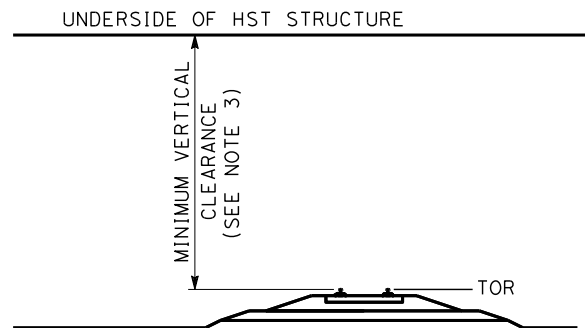

NEW HST STRUCTURE OVER TRACK

	MIN VERTICAL CLEARANCE
FREIGHT TRACKS	
BNSF	23'-4"
UPRR	23'-0"
NON-FREIGHT TRACKS	
METROLINK	24'-0"
CALTRAIN	24'-6"

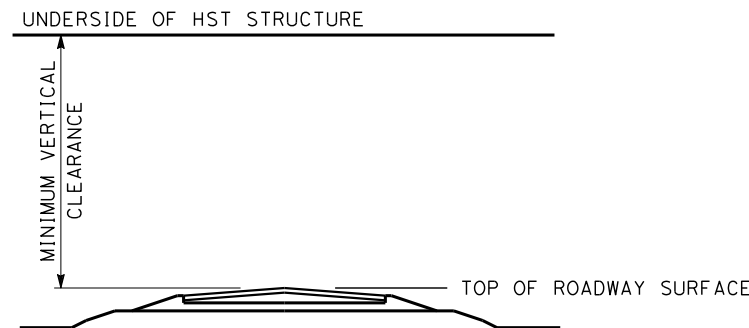

NEW HST STRUCTURE OVER ROADWAY

	MIN VERTICAL CLEARANCE
FREEWAY/EXPRESSWAY	16'-6"
LOCAL ROADWAY	15'-0"*
EXTRA LEGAL LOAD NETWORK(ELLN)	20'-3"

* SEE NOTE 6

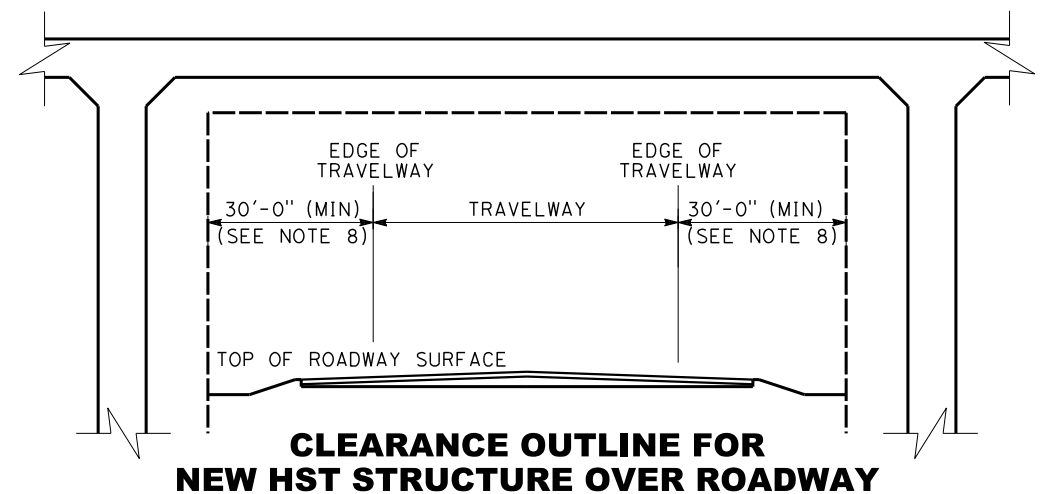
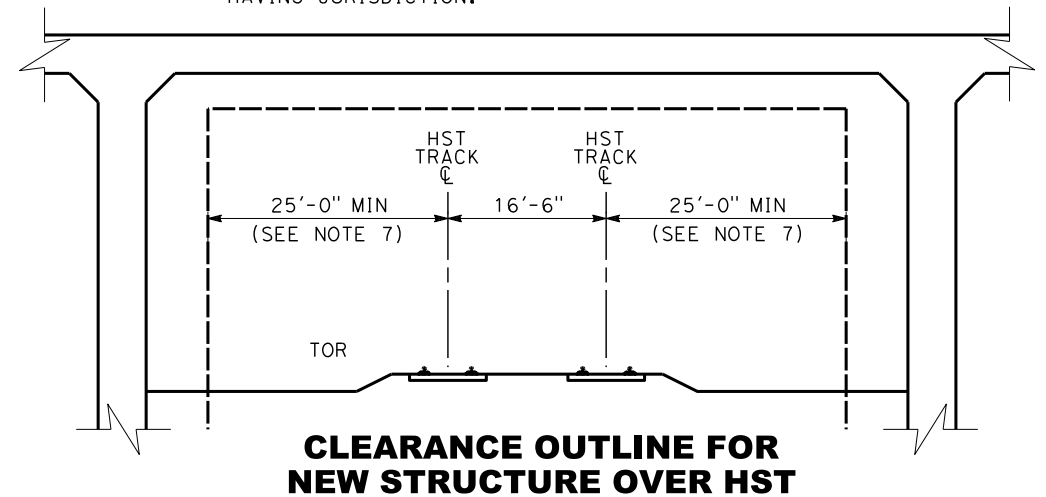

MIN SIDE CLEARANCE
 FREEWAY/EXPRESSWAY 30'-0"
 OTHER SEE NOTE 9

8/13/2013 2:30:30 PM CAHSR.TBL CHSR_half_black.plt C:\Users\huante\Desktop\wise\1.1.21-A.dgn

REV	DATE	BY	CHK	APP	DESCRIPTION

DESIGNED BY
S. MILITELLO
 DRAWN BY
V. HUANTE
 CHECKED BY
H. NGUYEN
 IN CHARGE
G. LUSHEROVICH
 DATE
08/13/2013



**CALIFORNIA HIGH-SPEED TRAIN PROJECT
 TECHNICAL MEMORANDUM**

MINIMUM CLEARANCE
 GRADE SEPARATED STRUCTURES

CONTRACT NO.
 DRAWING NO.
TM 1.1.21-A
 SCALE
NO SCALE
 SHEET NO.

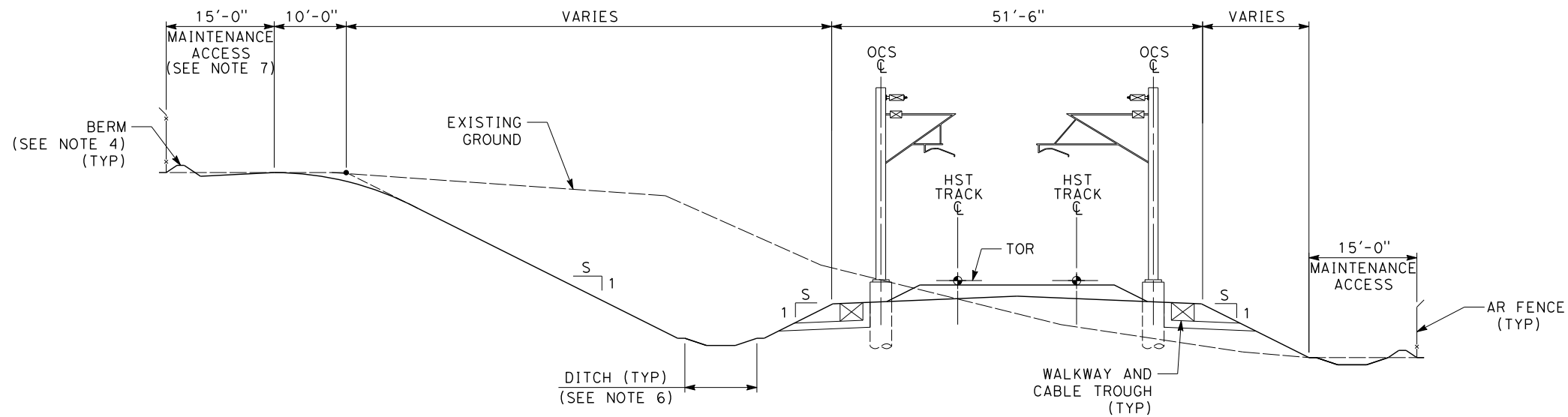

TYPICAL SECTION
AT-GRADE WITH OPEN DRAINAGE

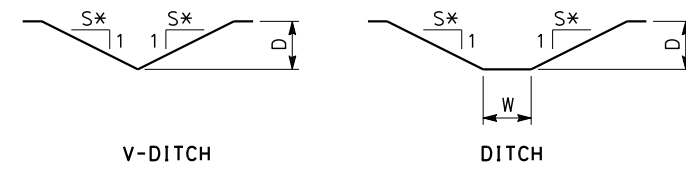

DITCH DETAILS
(SEE NOTE 6)

NOTES:

- RIGHT-OF-WAY REQUIRED FOR THE HIGH-SPEED RAIL TRACKWAY WILL DEPEND UPON CONDITIONS ALONG THE ALIGNMENT, INCLUDING TERRAIN, WHERE CUT/FILL SLOPES, RETAINING STRUCTURES, AND ACCESS ARE REQUIRED.
- FOR EMBANKMENT SLOPE GRADING, S=2 (MIN).
- FOR ADDITIONAL DESIGN GUIDANCE REFER TO TM 2.3.3 DESIGN GUIDELINES FOR HIGH-SPEED TRAIN AERIAL STRUCTURES.
- PROTECTIVE BARRIER, SUCH AS A BERM OR A DIKE, SHALL BE INSTALLED AT THE RIGHT-OF-WAY BOUNDARY TO INTERCEPT STORM WATER RUN OFF, WHERE THERE IS A POTENTIAL FOR STORM WATER RUN OFF TO ENTER CHST RIGHT-OF-WAY FROM ADJACENT PROPERTY.
- AR FENCE IS LOCATED 1 FOOT INSIDE FROM AUTHORITY'S RIGHT-OF-WAY.
- DITCH SHALL CONFORM TO THE FOLLOWING MINIMUM DIMENSIONS:
D = DEPTH OF DITCH, 1 FOOT MINIMUM
S* = SLOPE OF DITCH, SIDES, 3:1 MAX FOR GRASS LINED CHANNEL
W = WIDTH OF BOTTOM OF DITCH, 4 FEET MINIMUM
FLAT BOTTOM DITCH SHALL BE USED ALONGSIDE THE TRACKWAY TO COLLECT TRACKWAY RUN-OFF AND FOR MAINTENANCE ACCESS. IF REQUIRED, V-DITCH SHALL BE USED ALONG THE PERIMETER OF THE FACILITY SITES, WHICH ARE TYPICALLY WITHIN A CONFINED AREA.
- FOR CUT SLOPES HIGHER THAN 30 FEET, A 20-FOOT MAINTENANCE ACCESS WOULD BE REQUIRED.
- TO PROVIDE FOR SAFE CLEARANCE FROM OCS POLE-MOUNTED EQUIPMENT, NO STRUCTURE WHICH IS MORE THAN 10 FEET HIGH ABOVE TOP OF RAIL SHALL BE CONSTRUCTED WITHIN 9 FEET FROM THE FIELD-SIDE OF THE CENTERLINE OF THE OCS POLE.

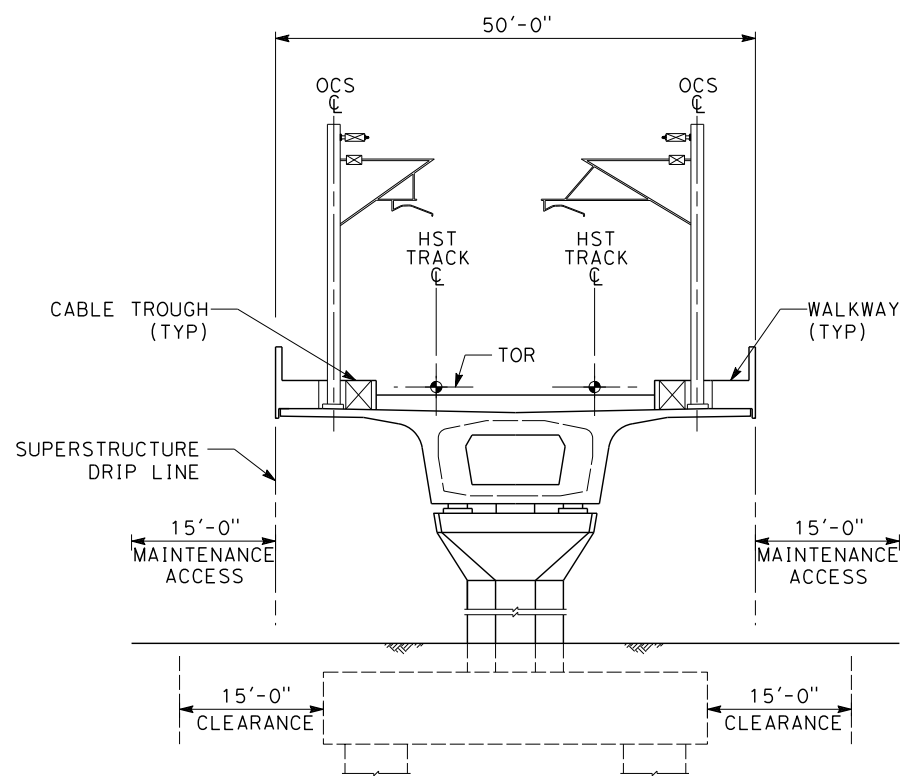

TYPICAL SECTION
AERIAL TRACKWAY

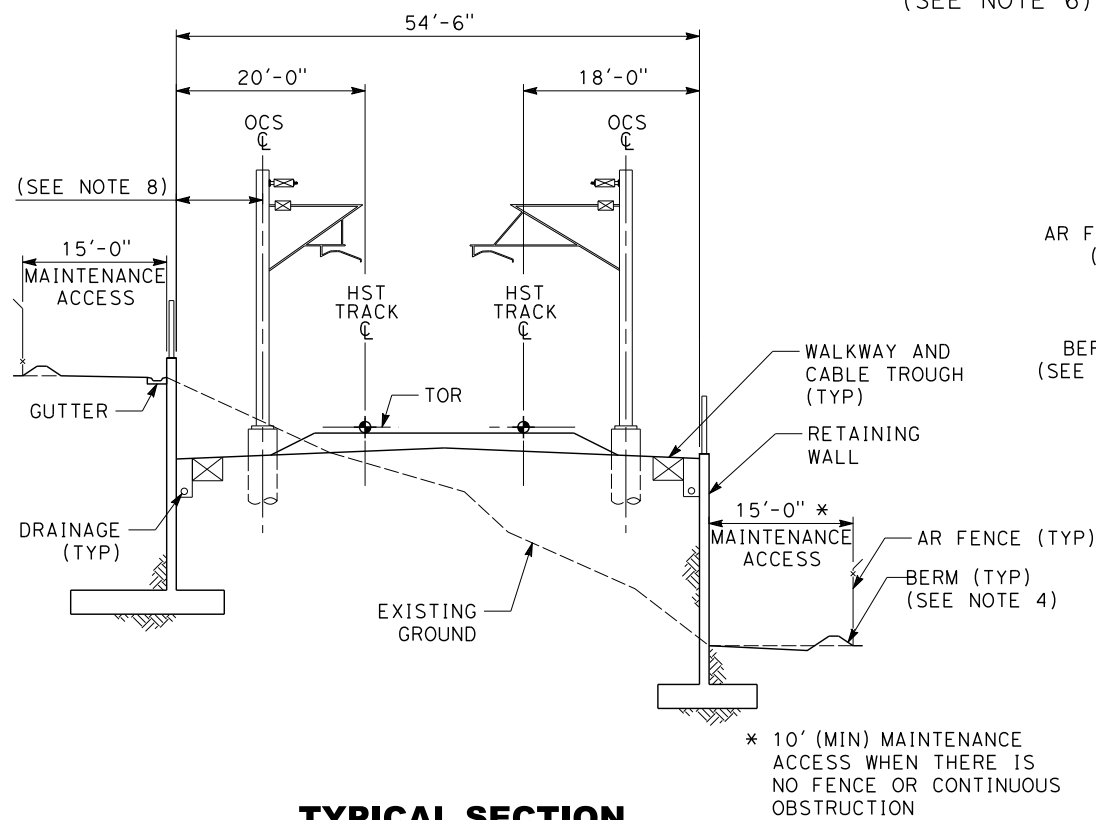

TYPICAL SECTION
RETAINED-CUT/RETAINED-FILL

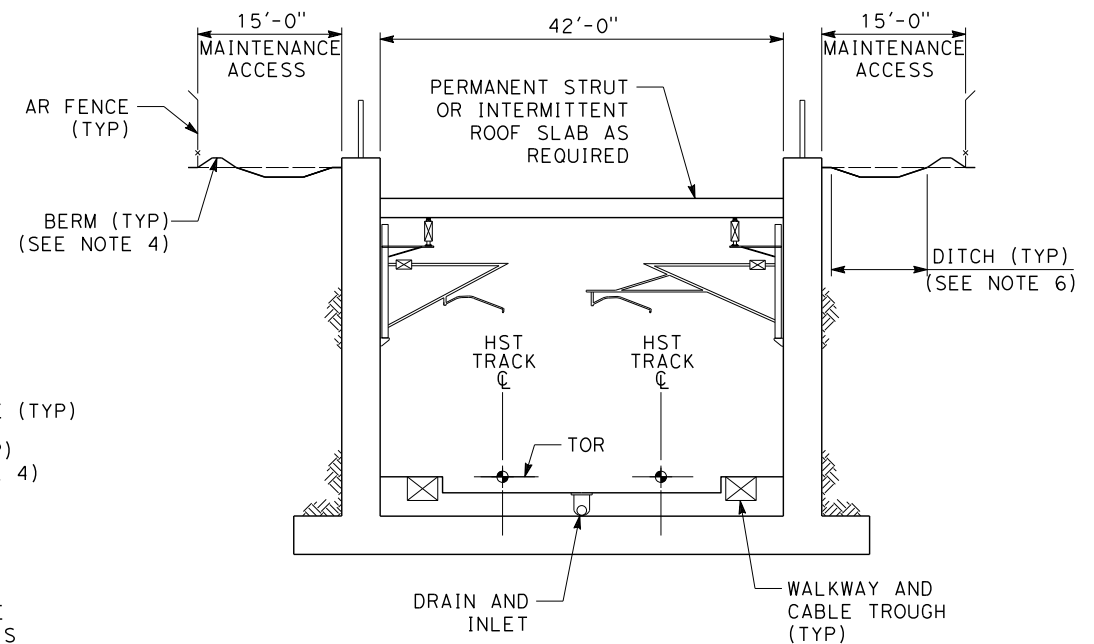

TYPICAL SECTION
TRENCH

8/13/2013 2:30:33 PM CAHSR.TBL CHSR_half_black.plt C:\Users\huante\Desktop\wise\1.1.21-B.dgn

REV	DATE	BY	CHK	APP	DESCRIPTION

DESIGNED BY
A. CHEUNG
DRAWN BY
V. HUANTE
CHECKED BY
S. MILITELLO
IN CHARGE
G. LUSHEROVICH
DATE
08/13/2013



CALIFORNIA HIGH-SPEED TRAIN PROJECT
TECHNICAL MEMORANDUM

TWO TRACK FORMATION
AT-GRADE, RETAINED-CUT, RETAINED-FILL,
AERIAL TRACKWAY AND TRENCH STRUCTURES

CONTRACT NO.
DRAWING NO.
TM 1.1.21-B
SCALE
NO SCALE
SHEET NO.

NOTES:

1. FOR ADDITIONAL DESIGN GUIDANCE REFER TO TM 2.4.2 BASIC HIGH-SPEED TRAIN TUNNEL CONFIGURATION.

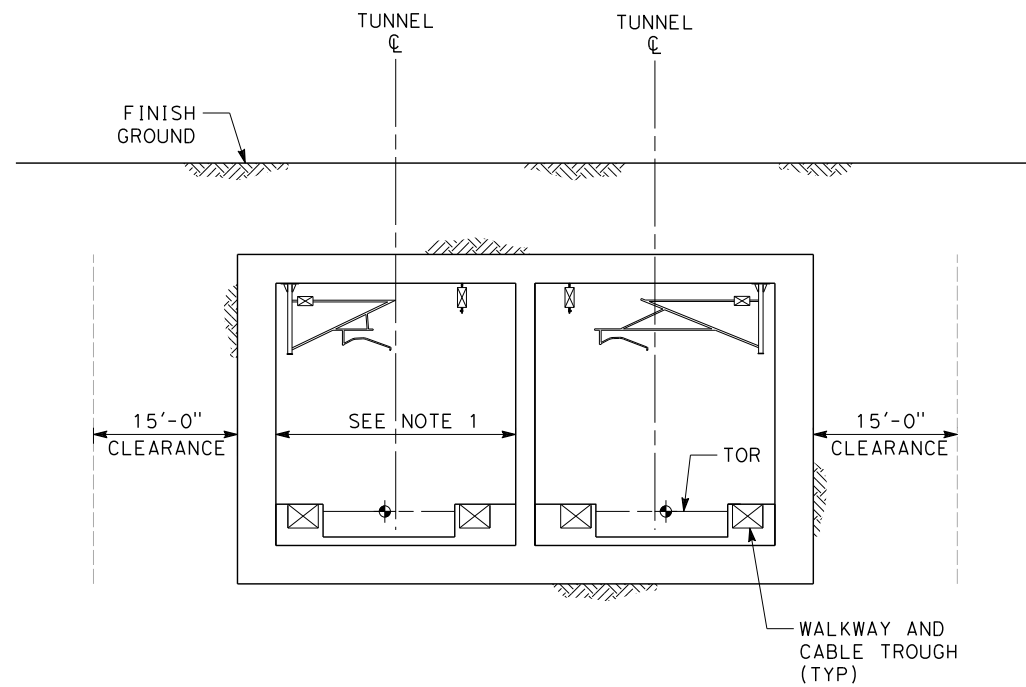

**TYPICAL SECTION
CUT & COVER TUNNEL**

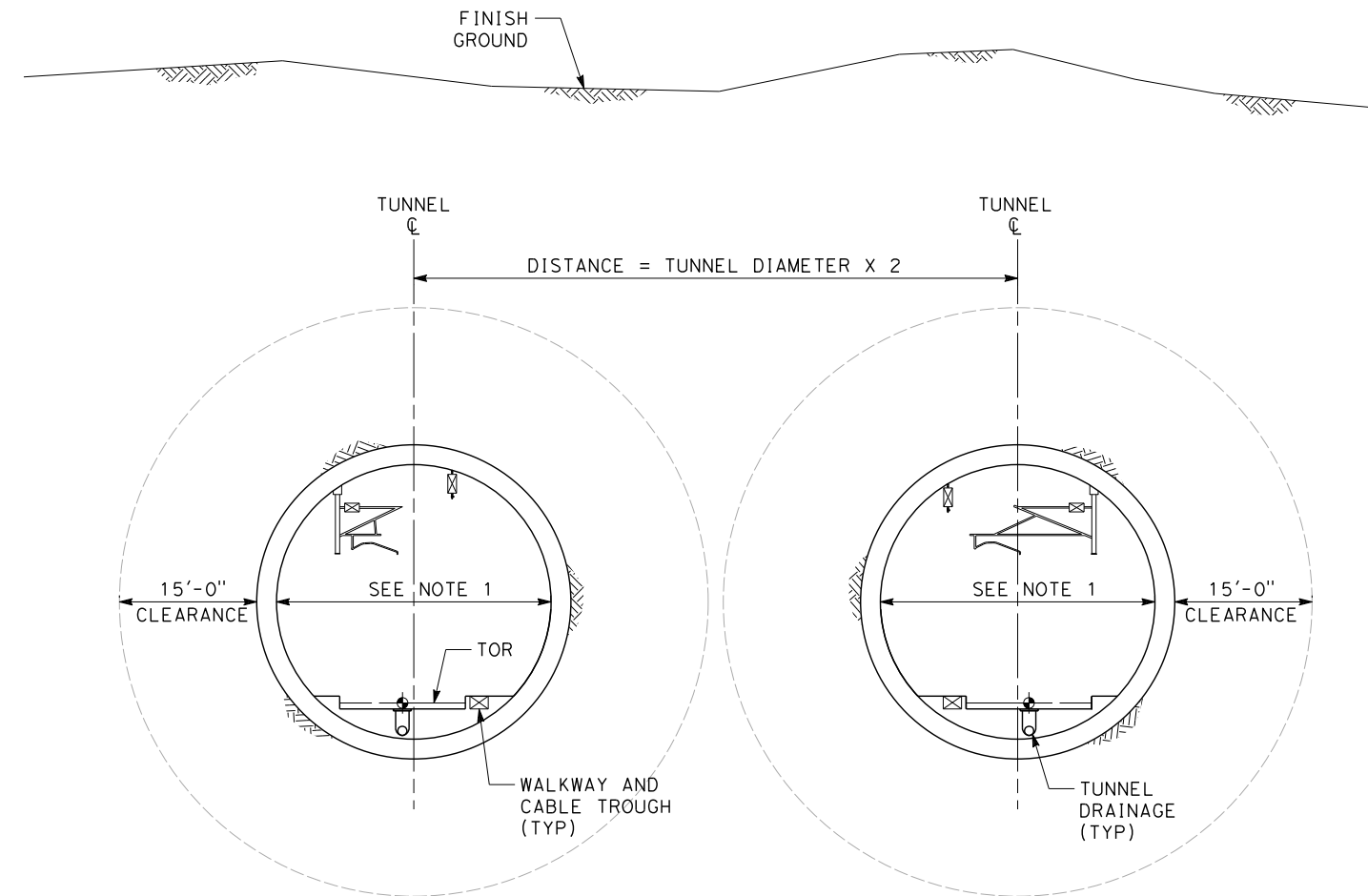

**TYPICAL SECTION
BORED TUNNEL**

8/13/2013 2:30:35 PM CAHSRP.TBL CHSR_half_black.plt C:\Users\huante\Desktop\Pwise\1.1.21-C.dgn

REV	DATE	BY	CHK	APP	DESCRIPTION

DESIGNED BY
A. CHEUNG
 DRAWN BY
V. HUANTE
 CHECKED BY
S. MILITELLO
 IN CHARGE
G. LUSHEROVICH
 DATE
08/13/2013



**CALIFORNIA HIGH-SPEED TRAIN PROJECT
TECHNICAL MEMORANDUM**

TWO TRACK FORMATION
TUNNEL STRUCTURES

CONTRACT NO.
 DRAWING NO.
TM 1.1.21-C
 SCALE
NO SCALE
 SHEET NO.

NOTES:

1. RIGHT-OF-WAY REQUIRED FOR THE HIGH-SPEED RAIL TRACKWAY WILL DEPEND UPON CONDITIONS ALONG THE ALIGNMENT, INCLUDING TERRAIN, WHERE CUT/FILL SLOPES, RETAINING STRUCTURES, AND ACCESS ARE REQUIRED.
2. FOR EMBANKMENT SLOPE GRADING, $S=2$ (MIN).
3. PROTECTIVE BARRIER, SUCH AS A BERM OR A DIKE, SHALL BE INSTALLED AT THE RIGHT-OF-WAY BOUNDARY TO INTERCEPT STORM WATER RUNOFF, WHERE THERE IS A POTENTIAL FOR STORM WATER RUNOFF TO ENTER CHSTS RIGHT FROM ADJACENT PROPERTY.
4. FOR SYSTEM REQUIREMENTS AT SINGLE TRACK AERIAL STRUCTURE, SEE DRAWING TM 1.1.21-G.
5. FOR DITCH DIMENSIONS REFER TO DRAWING TM 1.1.21-B.

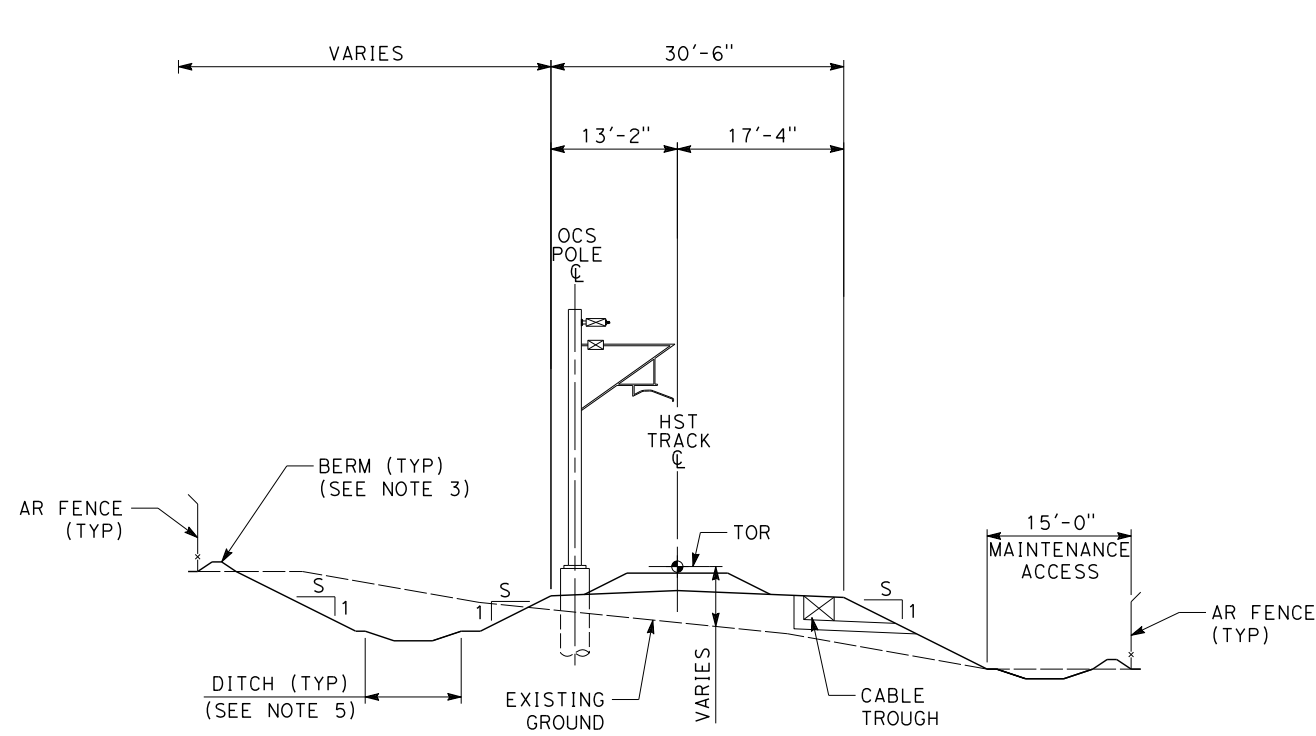

TYPICAL SECTION
AT-GRADE WITH OPEN DRAINAGE

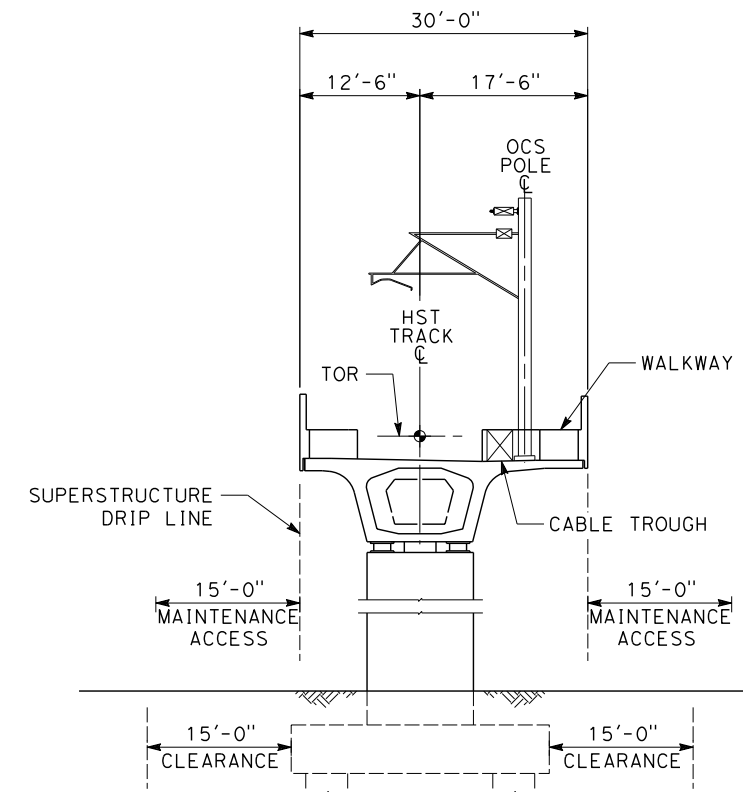

TYPICAL SECTION
AERIAL TRACKWAY

8/13/2013 2:30:37 PM CAHSRP.TBL CHSR_half_black.plt C:\Users\huante\Desktop\wise\1.1.21-D.dgn

REV	DATE	BY	CHK	APP	DESCRIPTION

DESIGNED BY
A. CHEUNG
 DRAWN BY
V. HUANTE
 CHECKED BY
S. MILITELLO
 IN CHARGE
G. LUSHEROVICH
 DATE
08/13/2013



CALIFORNIA HIGH-SPEED TRAIN PROJECT
TECHNICAL MEMORANDUM
 SINGLE TRACK FORMATION
 AT-GRADE AND AERIAL TRACKWAY STRUCTURES

CONTRACT NO.
 DRAWING NO.
TM 1.1.21-D
 SCALE
NO SCALE
 SHEET NO.

NOTES:

1. TRACK, OCS POLES AND FOUNDATIONS, CABLE TROUGHS, AND DRAINAGE ARE SCHEMATIC AND DO NOT REPRESENT DESIGN.
2. FOR ADDITIONAL DESIGN GUIDANCE REFER TO TM 2.1.3 TURNOUTS AND STATION TRACKS & TM 2.2.4 STATION PLATFORM GEOMETRIC DESIGN.

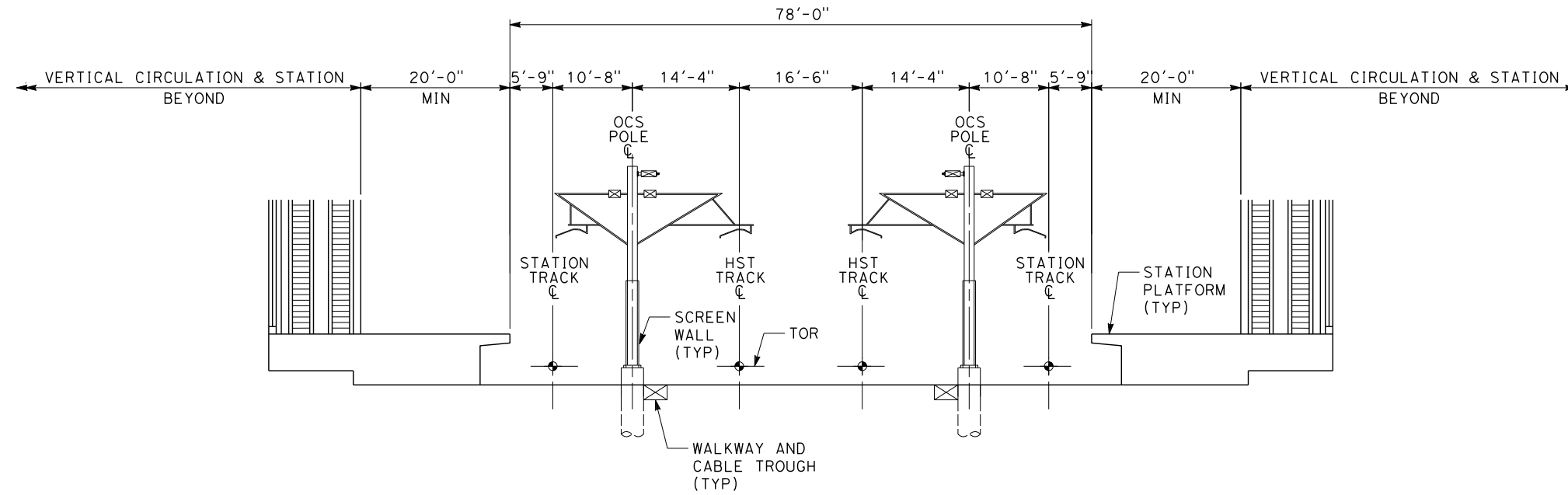

TYPICAL SECTION
AT-GRADE INTERMEDIATE STATION

8/13/2013 2:30:38 PM CAHSR.TBL CHSR_half_black.plt C:\Users\huante\Desktop\Pwise\1.1.21-E.dgn

REV	DATE	BY	CHK	APP	DESCRIPTION

DESIGNED BY
A. CHEUNG
DRAWN BY
V. HUANTE
CHECKED BY
S. MILITELLO
IN CHARGE
G. LUSHEROVICH
DATE
08/13/2013



CALIFORNIA HIGH-SPEED TRAIN PROJECT
TECHNICAL MEMORANDUM

FOUR TRACK FORMATION
AT-GRADE INTERMEDIATE STATION

CONTRACT NO.
DRAWING NO. TM 1.1.21-E
SCALE NO SCALE
SHEET NO.

8/13/2013 2:30:40 PM CAHSR.TBL CHSR_half_black.plt C:\Users\huante\Desktop\wise\1.1.21-F.dgn

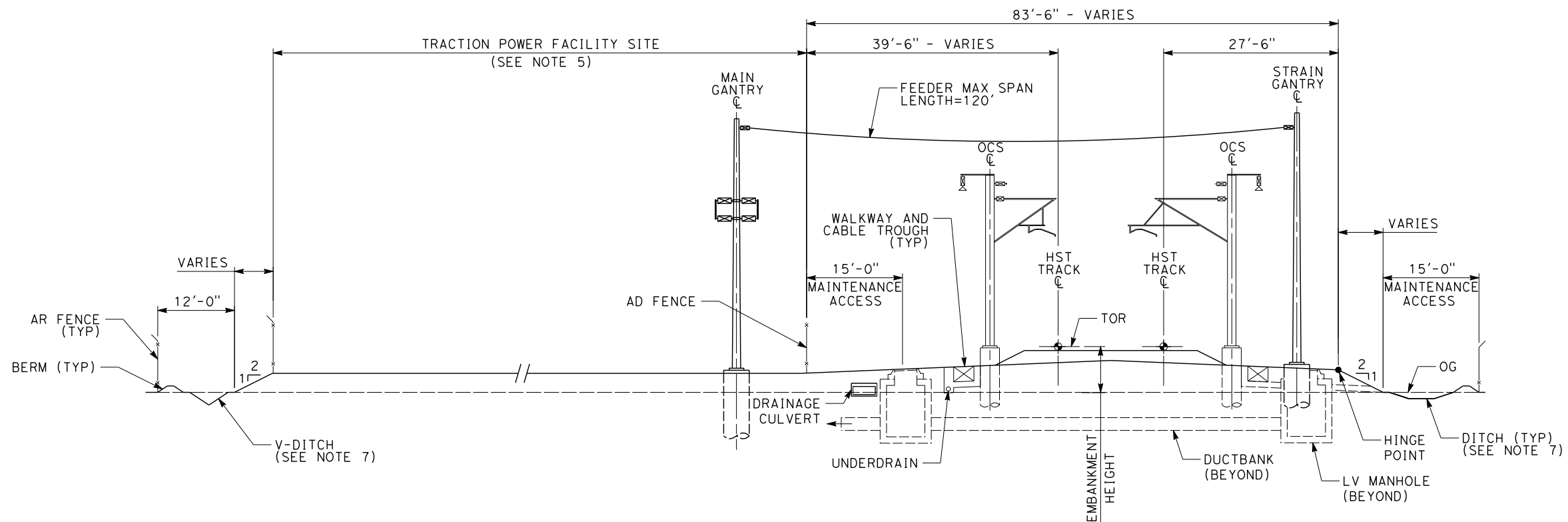

TYPICAL SECTION
 TRACTION POWER FACILITY SITE ADJACENT TO AT-GRADE HST TRACKWAY
 WITH EMBANKMENT HEIGHT (TOR-OG) ≤ 10 FEET

- NOTES:**
1. ALL DIMENSIONS ARE SHOWN AS MINIMUM REQUIREMENTS.
 2. RIGHT-OF-WAY REQUIRED FOR THE HIGH-SPEED RAIL TRACKWAY WILL DEPEND UPON CONDITIONS ALONG THE ALIGNMENT, INCLUDING TERRAIN, WHERE CUT/FILL SLOPES, RETAINING STRUCTURES, AND ACCESS ARE REQUIRED.
 3. SYSTEM SITES AWAY FROM TRACKWAY ARE UNDESIRABLE. AWAY CROSS-SECTION IS ONLY APPLICABLE IF ADJACENT SOLUTION IS DEMONSTRATED TO VIOLATE SITE SPACING REQUIREMENTS OR OTHER CRITICAL CRITERIA.
 4. TYPICAL CROSS-SECTIONAL WIDTH SHOWN SHALL BE PROVIDED FOR MINIMUM LENGTH EQUAL TO THE LONGITUDINAL WIDTH OF THE SYSTEMS SITE.
 5. FOR TRACTION POWER SITE REQUIREMENTS REFER TO TM 3.1.1.3 TRACTION POWER FACILITIES GENERAL STANDARDIZATION REQUIREMENTS.
 6. FOR ACCESS TO TRACKWAY REQUIREMENTS REFER TO TM 2.8.1 SAFETY AND SECURITY DESIGN REQUIREMENTS FOR INFRASTRUCTURE ELEMENTS.
 7. FOR V-DITCH AND DITCH DIMENSIONS REFER TO DRAWING TM 1.1.21-B.
 8. LOCATION OF A TRACTION POWER FACILITY SITE ADJACENT TO THE TRACKWAY WITH TRACK CENTERS OF MORE THAN 50 FEET APART OR AT DIFFERENT TRACKWAY ALIGNMENTS (E.G. SINGLE TRACK FOR AT-GRADE, AERIAL STRUCTURE, RETAINED FILL, TRENCH, ETC.) IS NOT DESIRABLE.

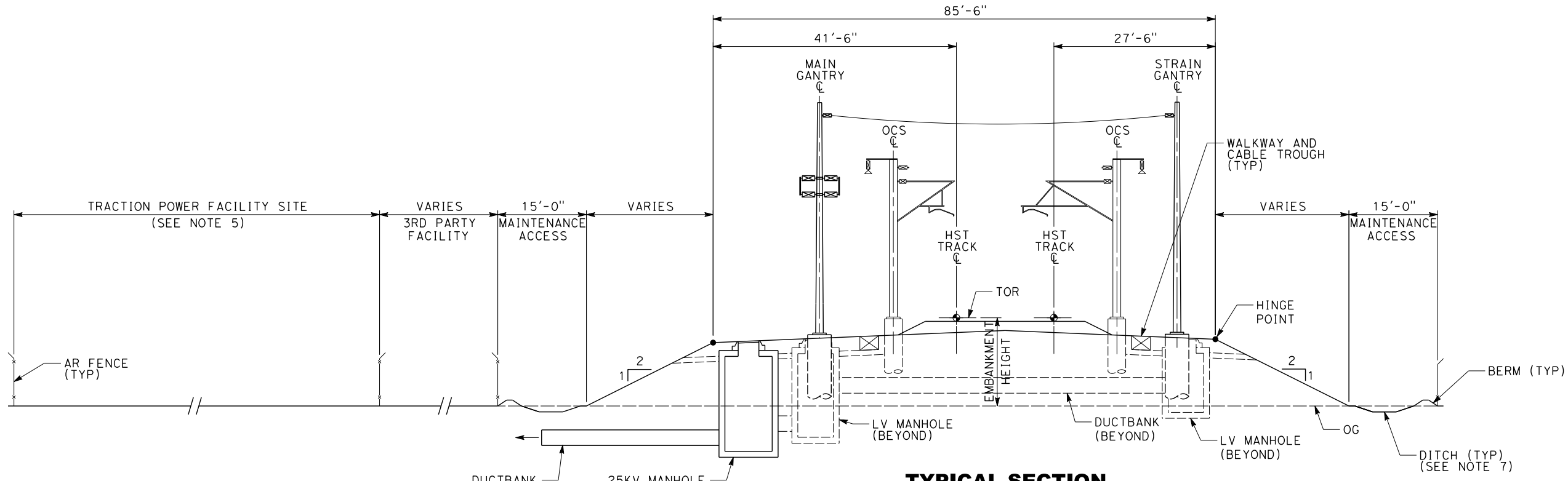

TYPICAL SECTION
 TRACTION POWER FACILITY SITE AWAY FROM AT-GRADE HST TRACKWAY OR
 EMBANKMENT HEIGHT (TOR-OG) > 10 FEET

REV	DATE	BY	CHK	APP	DESCRIPTION

DESIGNED BY
A. CHEUNG
 DRAWN BY
V. HUANTE
 CHECKED BY
S. MILITELLO
 IN CHARGE
G. LUSHEROVICH
 DATE
08/13/2013



CALIFORNIA HIGH-SPEED TRAIN PROJECT
TECHNICAL MEMORANDUM

 SYSTEMS SITE
 TRACTION POWER FACILITY
 AT-GRADE

CONTRACT NO.	
DRAWING NO.	TM 1.1.21-F
SCALE	NO SCALE
SHEET NO.	

NOTES:

1. ALL DIMENSIONS ARE SHOWN AS MINIMUM REQUIREMENTS.
2. RIGHT-OF-WAY REQUIRED FOR THE HIGH-SPEED RAIL TRACKWAY WILL DEPEND UPON CONDITIONS ALONG THE ALIGNMENT, INCLUDING TERRAIN, WHERE CUT/FILL SLOPES, RETAINING STRUCTURES, AND ACCESS ARE REQUIRED.
3. SYSTEM SITES ALONG TWO TRACK OR SINGLE TRACK AERIAL TRACKWAY ARE UNDESIRABLE. THESE CROSS-SECTIONS ARE ONLY APPLICABLE IF AT-GRADE SOLUTION IS DEMONSTRATED TO VIOLATE SITE SPACING REQUIREMENTS OR OTHER CRITICAL CRITERIA. ADDITIONAL EASEMENT SHALL BE NEEDED BETWEEN SINGLE TRACK AERIAL STRUCTURES FOR DUCTBANKS AND MANHOLES. ADDITIONAL EASEMENT REQUIRED BETWEEN SINGLE TRACK AERIAL TRACKWAY FOR DUCTBANKS AND MANHOLES.
4. SYSTEM SITES AWAY FROM TRACKWAY ARE UNDESIRABLE. AWAY CROSS-SECTION IS ONLY APPLICABLE IF ADJACENT SOLUTION IS DEMONSTRATED TO VIOLATE SITE SPACING REQUIREMENTS OR OTHER CRITICAL CRITERIA.
5. TYPICAL CROSS-SECTIONAL WIDTH SHOWN SHALL BE PROVIDED FOR MINIMUM LENGTH EQUAL TO THE LONGITUDINAL WIDTH OF THE SYSTEMS SITE TO BE COORDINATED WITH THE STRUCTURAL DESIGN.
6. TRACTION POWER FACILITY LOCATED AWAY FROM AERIAL STRUCTURE IS IDENTICAL TO ADJACENT CONDITION WITH DUCTBANKS RUNNING UNDERNEATH 3RD PARTY FACILITY.
7. FOR TRACTION POWER SITE REQUIREMENTS REFER TO TM 3.1.1.3 TRACTION POWER FACILITIES GENERAL STANDARDIZATION REQUIREMENTS.
8. FOR ACCESS TO TRACKWAY REQUIREMENTS REFER TO TM 2.8.1 SAFETY AND SECURITY DESIGN REQUIREMENTS FOR INFRASTRUCTURE ELEMENTS.

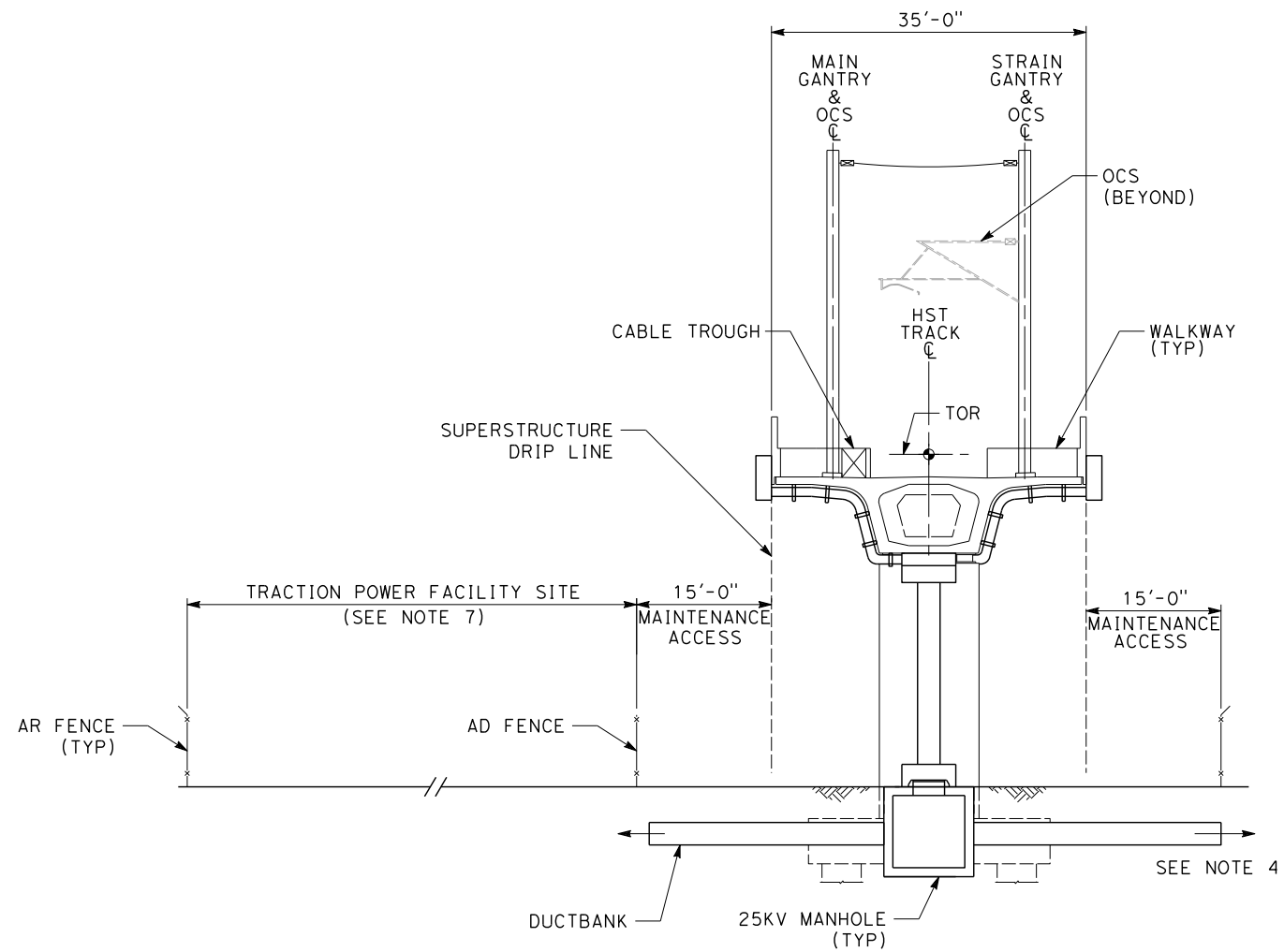

TYPICAL SECTION
TRACTION POWER FACILITY SITE AT SINGLE-TRACK AERIAL TRACKWAY

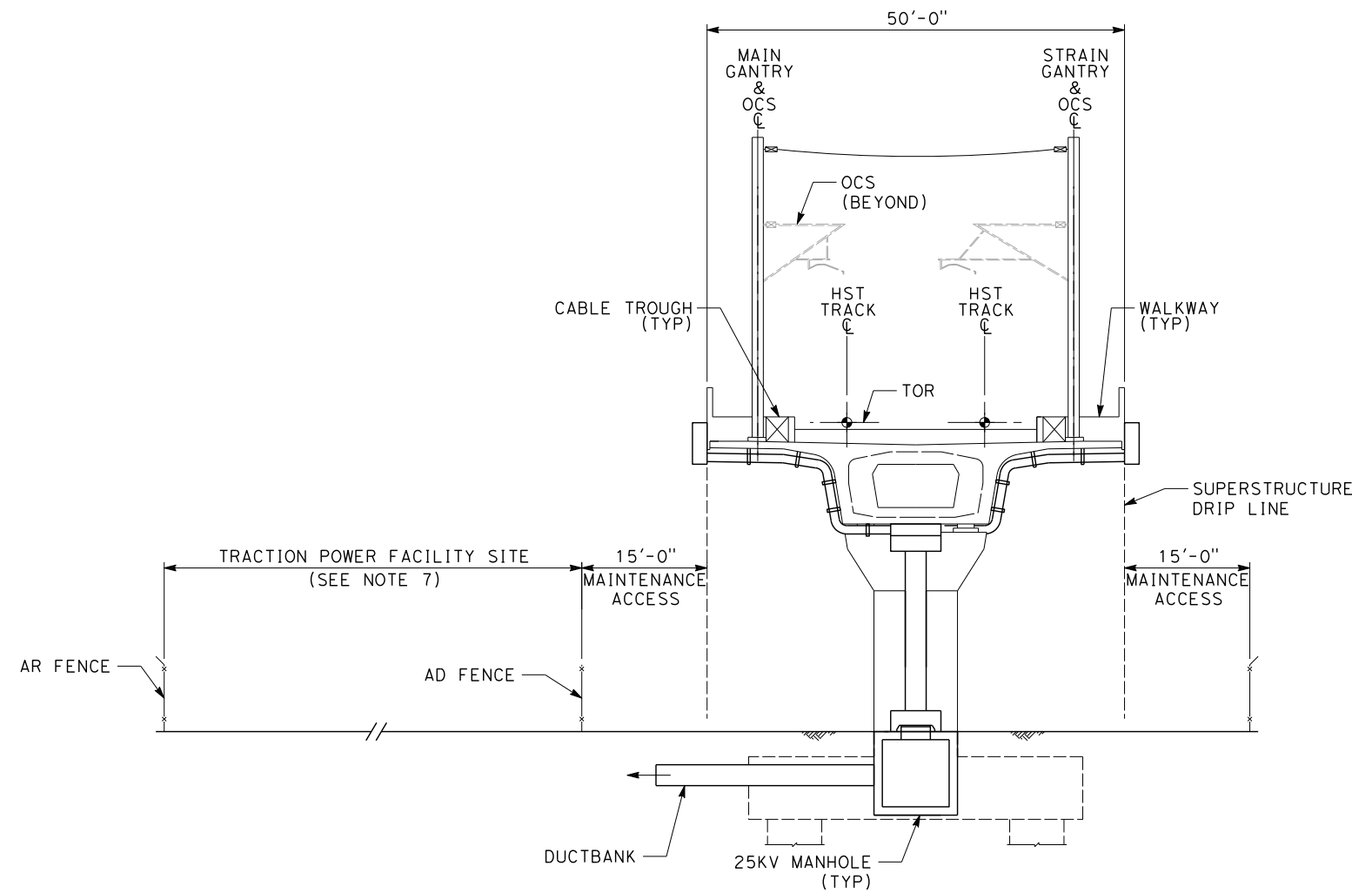

TYPICAL SECTION
TRACTION POWER FACILITY SITE AT TWO-TRACK AERIAL TRACKWAY

8/13/2013 2:30:41 PM CAHSR.TBL CHSR_half_black.plt C:\Users\huante\Desktop\wise\1.1.21-G.dgn

REV	DATE	BY	CHK	APP	DESCRIPTION

DESIGNED BY
A. CHEUNG
DRAWN BY
V. HUANTE
CHECKED BY
S. MILITELLO
IN CHARGE
G. LUSHEROVICH
DATE
08/13/2013



**CALIFORNIA HIGH-SPEED TRAIN PROJECT
TECHNICAL MEMORANDUM**

SYSTEMS SITE
TRACTION POWER FACILITY
AERIAL

CONTRACT NO.
DRAWING NO.
TM 1.1.21-G
SCALE
NO SCALE
SHEET NO.

8/13/2013 2:30:43 PM CAHSR.TBL CAHSR_half_black.plt C:\Users\huante\Desktop\wise\1.1.21-H.dgn

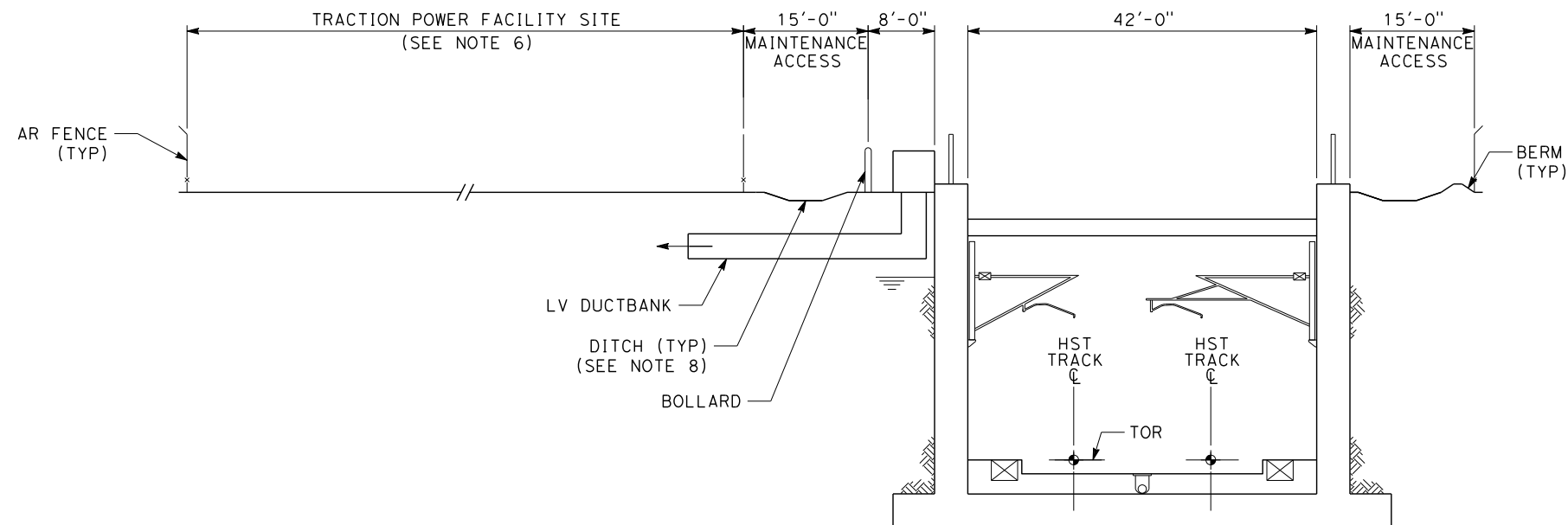

TYPICAL SECTION

TRACTION POWER FACILITY SITE ADJACENT TO TRENCH HST TRACKWAY

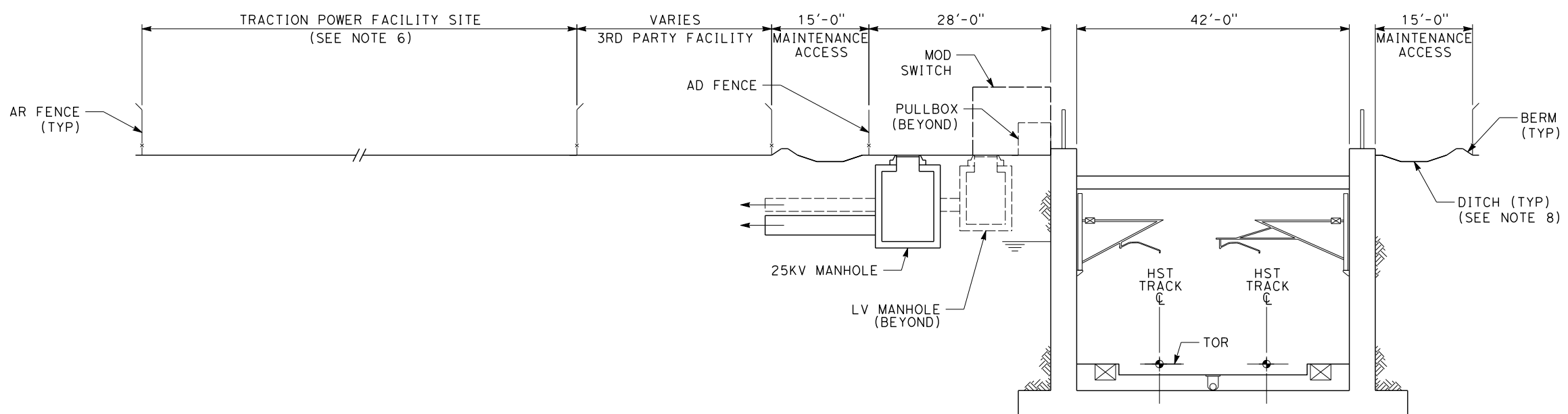

TYPICAL SECTION

TRACTION POWER FACILITY SITE AWAY FROM TRENCH HST TRACKWAY

NOTES:

1. ALL DIMENSIONS ARE SHOWN AS MINIMUM REQUIREMENTS.
2. RIGHT-OF-WAY REQUIRED FOR THE HIGH-SPEED RAIL TRACKWAY WILL DEPEND UPON CONDITIONS ALONG THE ALIGNMENT, INCLUDING TERRAIN, WHERE CUT/FILL SLOPES, RETAINING STRUCTURES, AND ACCESS ARE REQUIRED.
3. SYSTEM SITES ALONG TRENCH TRACKWAY ARE UNDESIRE. THESE CROSS-SECTIONS ARE ONLY APPLICABLE IF AT-GRADE SOLUTION IS DEMONSTRATED TO VIOLATE SITE SPACING REQUIREMENTS OR OTHER CRITICAL CRITERIA. ADDITIONAL EASEMENT REQUIRED BETWEEN SINGLE TRACK TRENCH TRACKWAY FOR DUCTBANKS AND MANHOLES.
4. SYSTEM SITES AWAY FROM TRACKWAY ARE UNDESIRE. AWAY CROSS-SECTION IS ONLY APPLICABLE IF ADJACENT SOLUTION IS DEMONSTRATED TO VIOLATE SITE SPACING REQUIREMENTS OR OTHER CRITICAL CRITERIA.
5. TYPICAL CROSS-SECTIONAL WIDTH SHOWN SHALL BE PROVIDED FOR MINIMUM LENGTH EQUAL TO THE LONGITUDINAL WIDTH OF THE SYSTEMS SITE.
6. FOR TRACTION POWER SITE REQUIREMENTS REFER TO TM 3.1.1.3 TRACTION POWER FACILITIES GENERAL STANDARDIZATION REQUIREMENTS.
7. FOR ACCESS TO TRACKWAY REQUIREMENTS REFER TO TM 2.8.1 SAFETY AND SECURITY DESIGN REQUIREMENTS FOR INFRASTRUCTURE ELEMENTS.
8. FOR DITCH DIMENSIONS REFER TO DRAWING TM 1.1.21-B.

REV	DATE	BY	CHK	APP	DESCRIPTION

DESIGNED BY
A. CHEUNG
 DRAWN BY
V. HUANTE
 CHECKED BY
S. MILITELLO
 IN CHARGE
G. LUSHEROVICH
 DATE
08/13/2013



CALIFORNIA HIGH-SPEED TRAIN PROJECT
TECHNICAL MEMORANDUM

 SYSTEMS SITE
 TRACTION POWER FACILITY
 TRENCH

CONTRACT NO.	
DRAWING NO.	TM 1.1.21-H
SCALE	NO SCALE
SHEET NO.	

8/13/2013 2:30:44 PM CAHSRP.TBL CHSR_half_black.plt C:\Users\huante\Desktop\wise\1.1.21-1.dgn

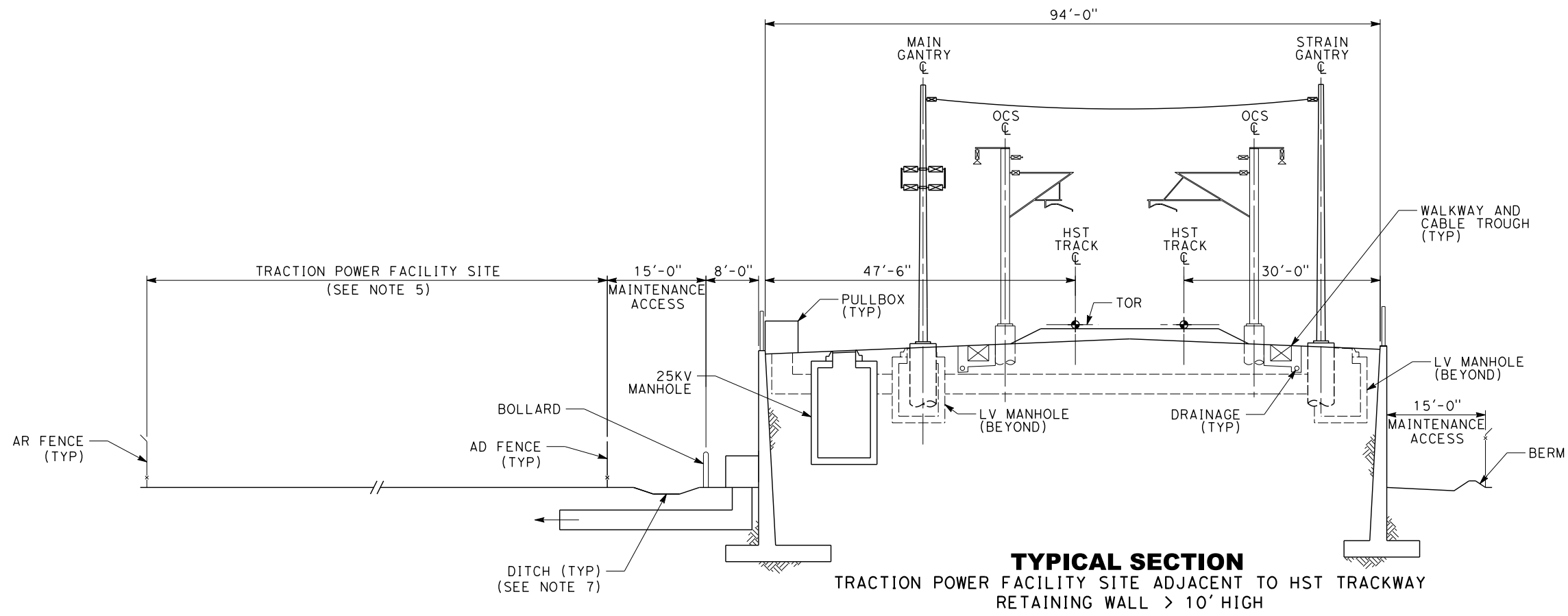

TYPICAL SECTION
 TRACTION POWER FACILITY SITE ADJACENT TO HST TRACKWAY
 RETAINING WALL > 10' HIGH

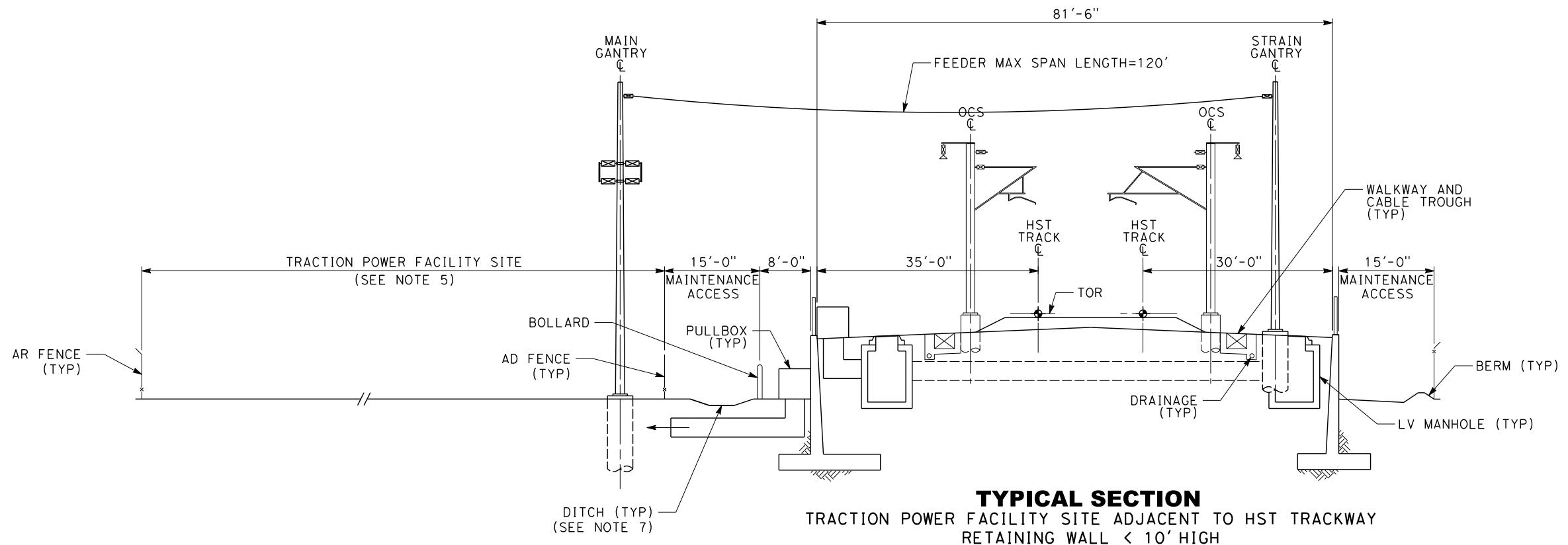

TYPICAL SECTION
 TRACTION POWER FACILITY SITE ADJACENT TO HST TRACKWAY
 RETAINING WALL ≤ 10' HIGH

- NOTES:**
1. ALL DIMENSIONS ARE SHOWN AS MINIMUM REQUIREMENTS.
 2. RIGHT-OF-WAY REQUIRED FOR THE HIGH-SPEED RAIL TRACKWAY WILL DEPEND UPON CONDITIONS ALONG THE ALIGNMENT, INCLUDING TERRAIN WHERE CUT/FILL SLOPES, RETAINING STRUCTURES, AND ACCESS ARE REQUIRED.
 3. SYSTEM SITES ALONG RETAINED-FILL TRACKWAY ARE UNDESIRE. THESE CROSS-SECTIONS ARE ONLY APPLICABLE IF AT-GRADE SOLUTION IS DEMONSTRATED TO VIOLATE SITE SPACING REQUIREMENTS OR OTHER CRITICAL CRITERIA. ADDITIONAL EASEMENT SHALL BE NEEDED BETWEEN SINGLE TRACK RETAINED-FILL TRACKWAY FOR DUCTBANKS AND MANHOLES.
 4. TYPICAL CROSS-SECTIONAL WIDTH SHOWN SHALL BE PROVIDED FOR MINIMUM LENGTH EQUAL TO THE LONGITUDINAL WIDTH OF THE SYSTEMS SITE.
 5. FOR TRACTION POWER SITE REQUIREMENTS REFER TO TM 3.1.1.3 TRACTION POWER FACILITIES GENERAL STANDARDIZATION REQUIREMENTS.
 6. FOR ACCESS TO TRACKWAY REQUIREMENTS REFER TO TM 2.8.1 SAFETY AND SECURITY DESIGN REQUIREMENTS FOR INFRASTRUCTURE ELEMENTS.
 7. FOR DITCH DIMENSIONS REFER TO DRAWING TM 1.1.21-B.
 8. FOR RETAINED-FILL TRACKWAYS, REINFORCED CONCRETE RETAINING WALLS SHALL BE USED AT TRACTION POWER FACILITY SITES.

REV	DATE	BY	CHK	APP	DESCRIPTION

DESIGNED BY
A. CHEUNG
 DRAWN BY
V. HUANTE
 CHECKED BY
S. MILITELLO
 IN CHARGE
G. LUSHEROVICH
 DATE
08/13/2013



CALIFORNIA HIGH-SPEED TRAIN PROJECT
TECHNICAL MEMORANDUM

 SYSTEMS SITE
 TRACTION POWER FACILITY
 RETAINED-FILL 1

CONTRACT NO.
 DRAWING NO.
 TM 1.1.21-1
 SCALE
 NO SCALE
 SHEET NO.

NOTES:

1. ALL DIMENSIONS ARE SHOWN AS MINIMUM REQUIREMENTS.
2. RIGHT-OF-WAY REQUIRED FOR THE HIGH-SPEED RAIL TRACKWAY WILL DEPEND UPON CONDITIONS ALONG THE ALIGNMENT, INCLUDING TERRAIN WHERE CUT/FILL SLOPES, RETAINING STRUCTURES, AND ACCESS ARE REQUIRED.
3. SYSTEM SITES ALONG RETAINED-FILL TRACKWAY ARE UNDESIRABLE. THIS CROSS-SECTION IS ONLY APPLICABLE IF AT-GRADE SOLUTION IS DEMONSTRATED TO VIOLATE SITE SPACING REQUIREMENTS OR OTHER CRITICAL CRITERIA. ADDITIONAL EASEMENT REQUIRED BETWEEN SINGLE TRACK RETAINED-FILL TRACKWAY FOR DUCTBANKS AND MANHOLES.
4. SYSTEM SITES AWAY FROM TRACKWAY ARE UNDESIRABLE. AWAY CROSS-SECTION IS ONLY APPLICABLE IF ADJACENT SOLUTION IS DEMONSTRATED TO VIOLATE SITE SPACING REQUIREMENTS OR OTHER CRITICAL CRITERIA.
5. TYPICAL CROSS-SECTIONAL WIDTH SHOWN SHALL BE PROVIDED FOR MINIMUM LENGTH EQUAL TO THE LONGITUDINAL WIDTH OF THE SYSTEMS SITE.
6. FOR TRACTION POWER SITE REQUIREMENTS REFER TO TM 3.1.1.3 TRACTION POWER FACILITIES GENERAL STANDARDIZATION REQUIREMENTS.
7. FOR ACCESS TO TRACKWAY REQUIREMENTS REFER TO TM 2.8.1 SAFETY AND SECURITY DESIGN REQUIREMENTS FOR INFRASTRUCTURE ELEMENTS.
8. FOR RETAINED-FILL TRACKWAYS, REINFORCED CONCRETE RETAINING WALLS SHALL BE USED AT TRACTION POWER FACILITY SITES.

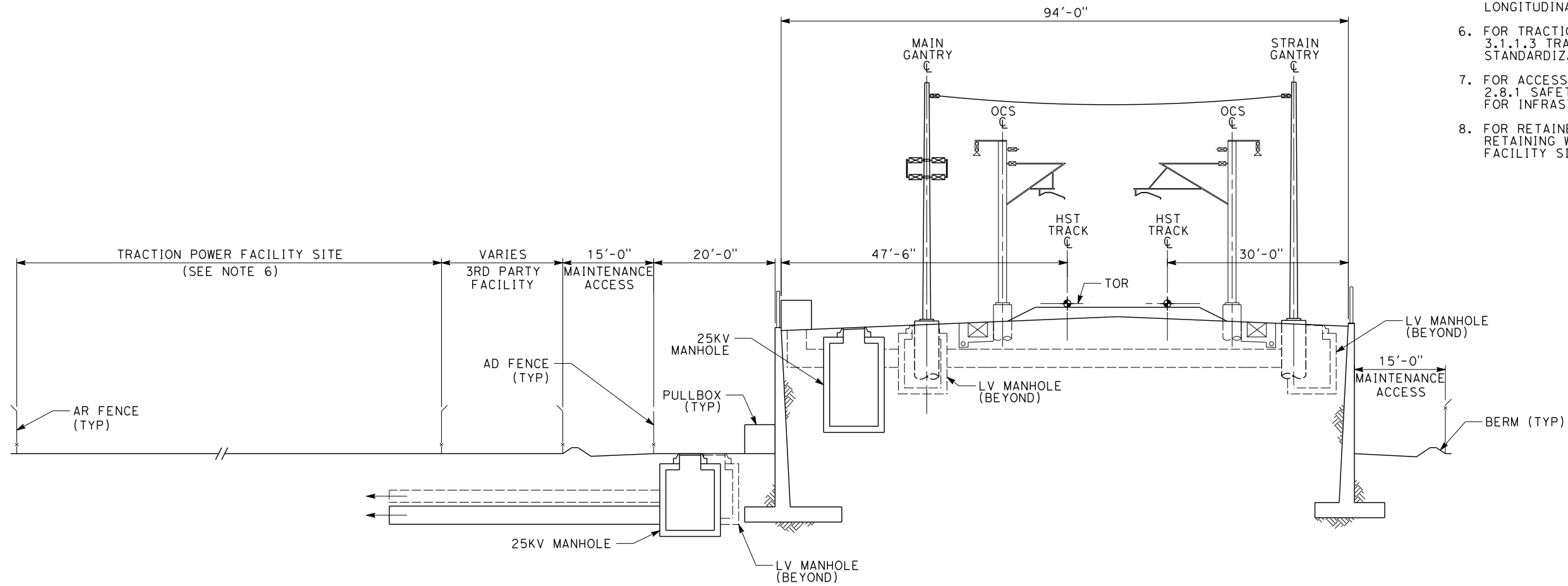

TYPICAL SECTION
TRACTION POWER FACILITY SITE AWAY FROM RETAINED-FILL HST TRACKWAY

8/13/2013 2:30:46 PM CAHSRP.TBL CHSR_half_black.plt C:\Users\huante\Desktop\wise\1.1.21-J.dgn

REV	DATE	BY	CHK	APP	DESCRIPTION

DESIGNED BY
A. CHEUNG
DRAWN BY
V. HUANTE
CHECKED BY
S. MILITELLO
IN CHARGE
G. LUSHEROVICH
DATE
08/13/2013



CALIFORNIA HIGH-SPEED TRAIN PROJECT
TECHNICAL MEMORANDUM

SYSTEMS SITE
TRACTION POWER FACILITY
RETAINED-FILL 2

CONTRACT NO.
DRAWING NO. TM 1.1.21-J
SCALE NO SCALE
SHEET NO.

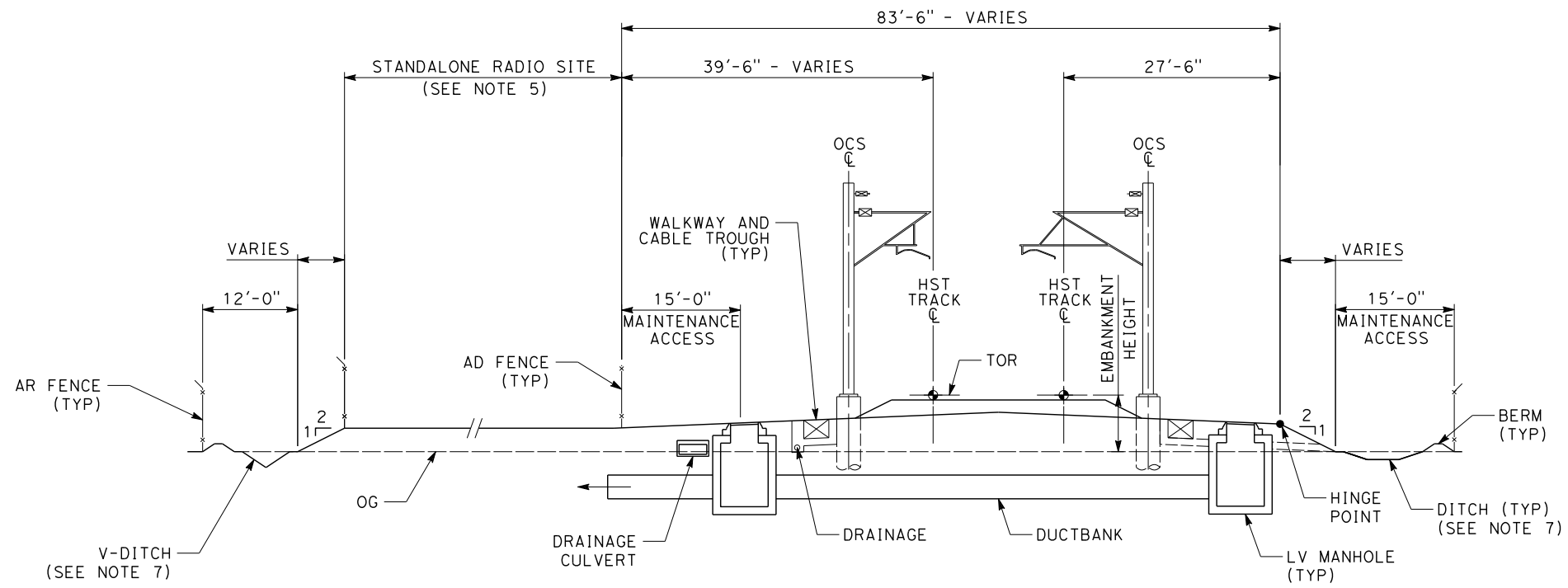

TYPICAL SECTION
 STANDALONE RADIO SITE ADJACENT TO AT-GRADE HST TRACKWAY
 WITH EMBANKMENT HEIGHT (TOR-OG) ≤ 10 FEET

NOTES:

1. ALL DIMENSIONS ARE SHOWN AS MINIMUM REQUIREMENTS.
2. RIGHT-OF-WAY REQUIRED FOR THE HIGH-SPEED RAIL TRACKWAY WILL DEPEND UPON CONDITIONS ALONG THE ALIGNMENT, INCLUDING TERRAIN, WHERE CUT/FILL SLOPES, RETAINING STRUCTURES, AND ACCESS ARE REQUIRED.
3. SYSTEM SITES AWAY FROM TRACKWAY ARE UNDESIRABLE. AWAY CROSS-SECTION IS ONLY APPLICABLE IF ADJACENT SOLUTION IS DEMONSTRATED TO VIOLATE SITE SPACING REQUIREMENTS OR OTHER CRITICAL CRITERIA.
4. TYPICAL CROSS-SECTIONAL WIDTH SHOWN SHALL BE PROVIDED FOR MINIMUM LENGTH EQUAL TO THE LONGITUDINAL WIDTH OF THE SYSTEMS SITE.
5. FOR STANDALONE RADIO SITE REQUIREMENTS REFER TO TM 3.4.2 COMMUNICATIONS SYSTEMS SITE REQUIREMENTS.
6. FOR ACCESS TO TRACKWAY REQUIREMENTS REFER TO TM 2.8.1 SAFETY AND SECURITY DESIGN REQUIREMENTS FOR INFRASTRUCTURE ELEMENTS.
7. FOR V-DITCH AND DITCH DIMENSIONS REFER TO DRAWING TM 1.1.21-B.

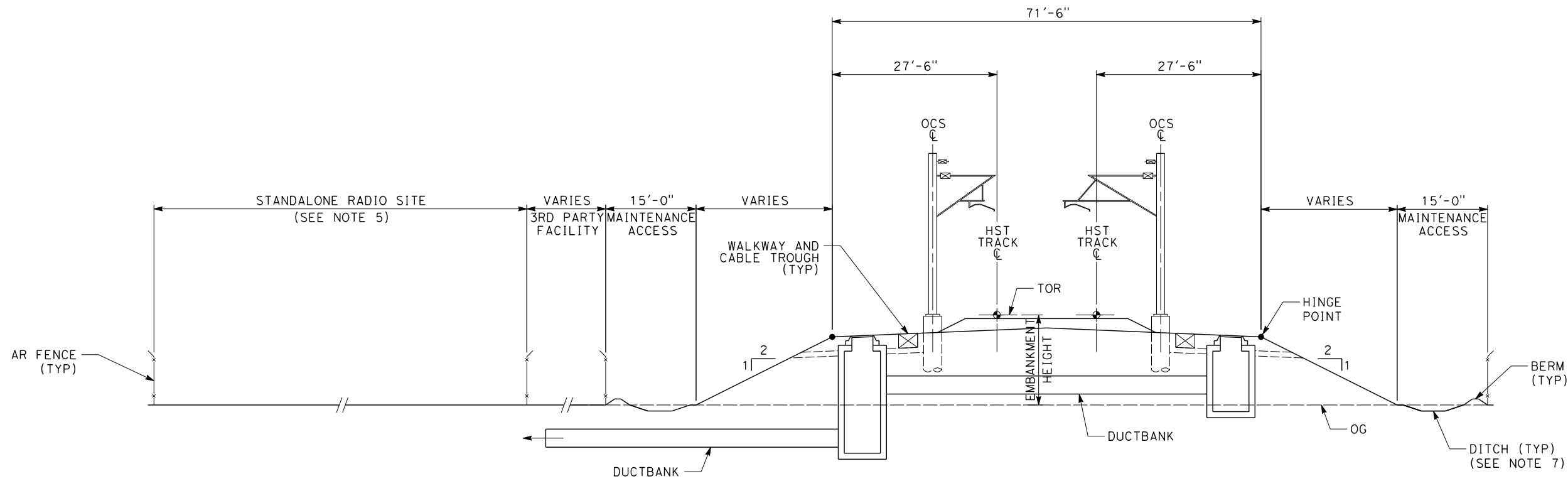

TYPICAL SECTION
 STANDALONE RADIO SITE AWAY FROM AT-GRADE HST TRACKWAY OR
 EMBANKMENT HEIGHT (TOR-OG) > 10 FEET

8/13/2013 2:30:48 PM CAHSRP.TBL CHSR_half_black.plt C:\Users\huante\Desktop\wise\1.1.21-K.dgn

REV	DATE	BY	CHK	APP	DESCRIPTION

DESIGNED BY
 A. CHEUNG
 DRAWN BY
 V. HUANTE
 CHECKED BY
 S. MILITELLO
 IN CHARGE
 G. LUSHEROVICH
 DATE
 08/13/2013



CALIFORNIA HIGH-SPEED TRAIN PROJECT
TECHNICAL MEMORANDUM
 SYSTEMS SITE
 STANDALONE RADIO SITE
 AT-GRADE

CONTRACT NO.
DRAWING NO. TM 1.1.21-K
SCALE NO SCALE
SHEET NO.

8/13/2013 2:30:49 PM CAHSRP.TBL CHSR_half_black.plt C:\Users\huante\Desktop\wise\1.1.21-L.dgn

NOTES:

1. ALL DIMENSIONS ARE SHOWN AS MINIMUM REQUIREMENTS.
2. RIGHT-OF-WAY REQUIRED FOR THE HIGH-SPEED RAIL TRACKWAY WILL DEPEND UPON CONDITIONS ALONG THE ALIGNMENT, INCLUDING TERRAIN, WHERE CUT/FILL SLOPES, RETAINING STRUCTURES, AND ACCESS ARE REQUIRED.
3. SYSTEM SITES ALONG AERIAL TRACKWAY ARE UNDESIRABLE. THIS CROSS-SECTION IS ONLY APPLICABLE IF AT-GRADE SOLUTION IS DEMONSTRATED TO VIOLATE SITE SPACING REQUIREMENTS OR OTHER CRITICAL CRITERIA.
4. STANDALONE RADIO SITE LOCATED AWAY FROM AERIAL STRUCTURE IS IDENTICAL TO ADJACENT CONDITION WITH DUCTBANKS RUNNING UNDERNEATH 3RD PARTY FACILITY.
5. TYPICAL CROSS-SECTIONAL WIDTH SHOWN SHALL BE PROVIDED FOR MINIMUM LENGTH EQUAL TO THE LONGITUDINAL WIDTH OF THE SYSTEMS SITE.
6. FOR STANDALONE RADIO SITE REQUIREMENTS REFER TO TM 3.4.2 COMMUNICATIONS SYSTEMS SITE REQUIREMENTS.
7. FOR ACCESS TO TRACKWAY REQUIREMENTS REFER TO TM 2.8.1 SAFETY AND SECURITY DESIGN REQUIREMENTS FOR INFRASTRUCTURE ELEMENTS.

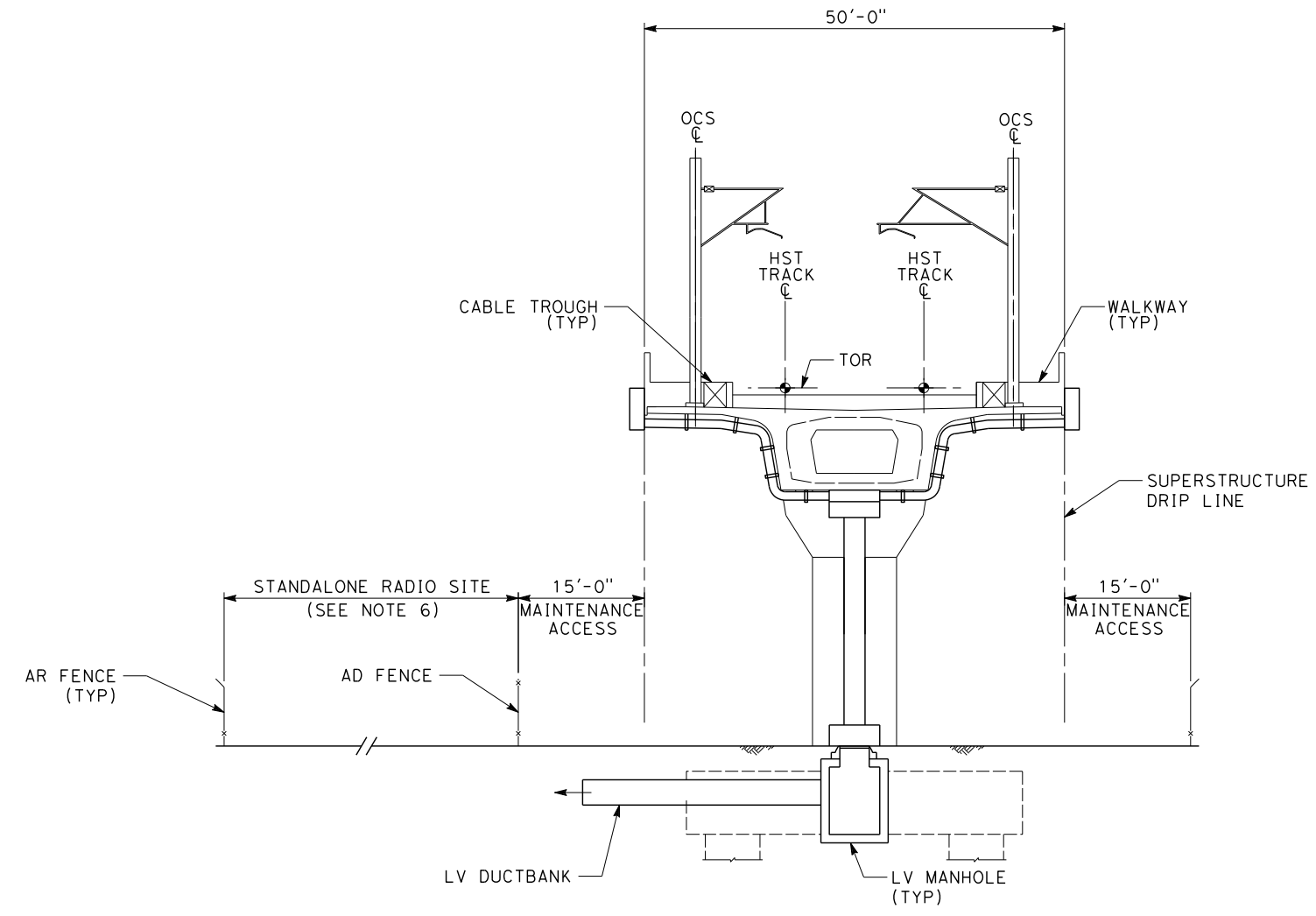

TYPICAL SECTION
STANDALONE RADIO SITE AT AERIAL TRACKWAY

REV	DATE	BY	CHK	APP	DESCRIPTION

DESIGNED BY
A. CHEUNG
 DRAWN BY
V. HUANTE
 CHECKED BY
S. MILITELLO
 IN CHARGE
G. LUSHEROVICH
 DATE
08/13/2013



CALIFORNIA HIGH-SPEED TRAIN PROJECT
TECHNICAL MEMORANDUM

 SYSTEMS SITE
 STANDALONE RADIO SITE
 AERIAL

CONTRACT NO.
DRAWING NO. TM 1.1.21-L
SCALE NO SCALE
SHEET NO.

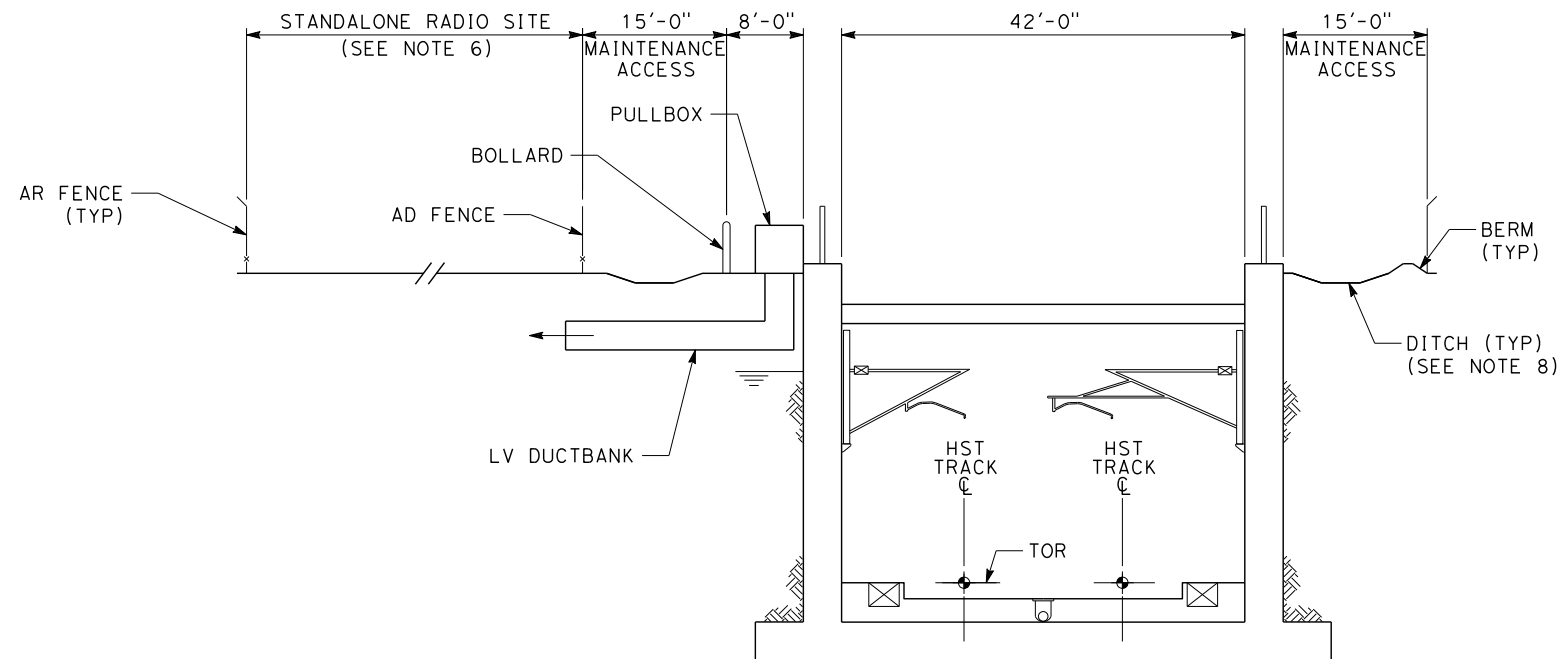

TYPICAL SECTION
STANDALONE RADIO SITE ADJACENT TO TRENCH HST TRACKWAY

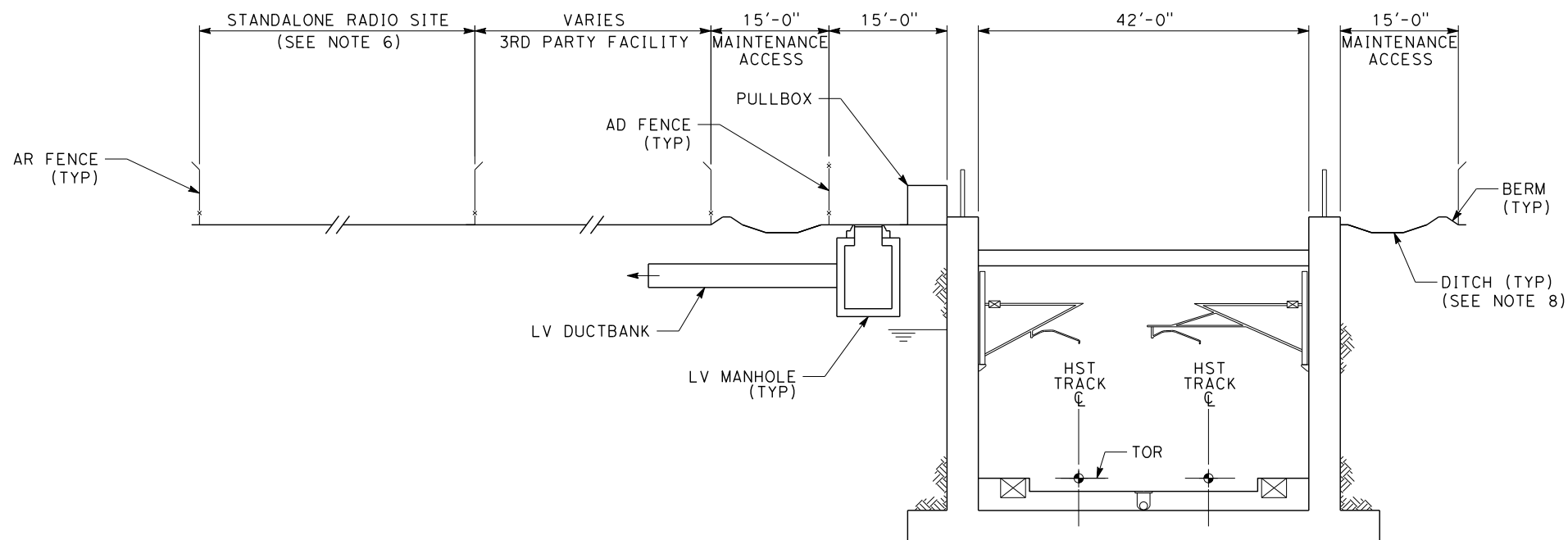

TYPICAL SECTION
STANDALONE RADIO SITE AWAY FROM TRENCH HST TRACKWAY

NOTES:

1. ALL DIMENSIONS ARE SHOWN AS MINIMUM REQUIREMENTS.
2. RIGHT-OF-WAY REQUIRED FOR THE HIGH-SPEED RAIL TRACKWAY WILL DEPEND UPON CONDITIONS ALONG THE ALIGNMENT, INCLUDING TERRAIN, WHERE CUT/FILL SLOPES, RETAINING STRUCTURES, AND ACCESS ARE REQUIRED.
3. SYSTEM SITES ALONG TRENCH TRACKWAY ARE UNDESIRABLE. THESE CROSS-SECTIONS ARE ONLY APPLICABLE IF AT-GRADE SOLUTION IS DEMONSTRATED TO VIOLATE SITE SPACING REQUIREMENTS OR OTHER CRITICAL CRITERIA.
4. SYSTEM SITES AWAY FROM TRACKWAY ARE UNDESIRABLE. AWAY CROSS-SECTION IS ONLY APPLICABLE IF ADJACENT SOLUTION IS DEMONSTRATED TO VIOLATE SITE SPACING REQUIREMENTS OR OTHER CRITICAL CRITERIA.
5. TYPICAL CROSS-SECTIONAL WIDTH SHOWN SHALL BE PROVIDED FOR MINIMUM LENGTH EQUAL TO THE LONGITUDINAL WIDTH OF THE SYSTEMS SITE.
6. FOR STANDALONE RADIO SITE REQUIREMENTS REFER TO TM 3.4.2 COMMUNICATIONS SYSTEMS SITE REQUIREMENTS.
7. FOR ACCESS TO TRACKWAY REQUIREMENTS REFER TO TM 2.8.1 SAFETY AND SECURITY DESIGN REQUIREMENTS FOR INFRASTRUCTURE ELEMENTS.
8. FOR DITCH DIMENSIONS REFER TO DRAWING TM 1.1.21-B.

8/13/2013 2:30:51 PM C:\Users\huante\Desktop\wise\1.1.21-M.dgn

REV	DATE	BY	CHK	APP	DESCRIPTION

DESIGNED BY A. CHEUNG
DRAWN BY V. HUANTE
CHECKED BY S. MILITELLO
IN CHARGE G. LUSHEROVICH
DATE 08/13/2013

--	--	--	--



CALIFORNIA HIGH-SPEED TRAIN PROJECT
TECHNICAL MEMORANDUM

SYSTEMS SITE
STANDALONE RADIO SITE
TRENCH

CONTRACT NO.
DRAWING NO. TM 1.1.21-M
SCALE NO SCALE
SHEET NO.

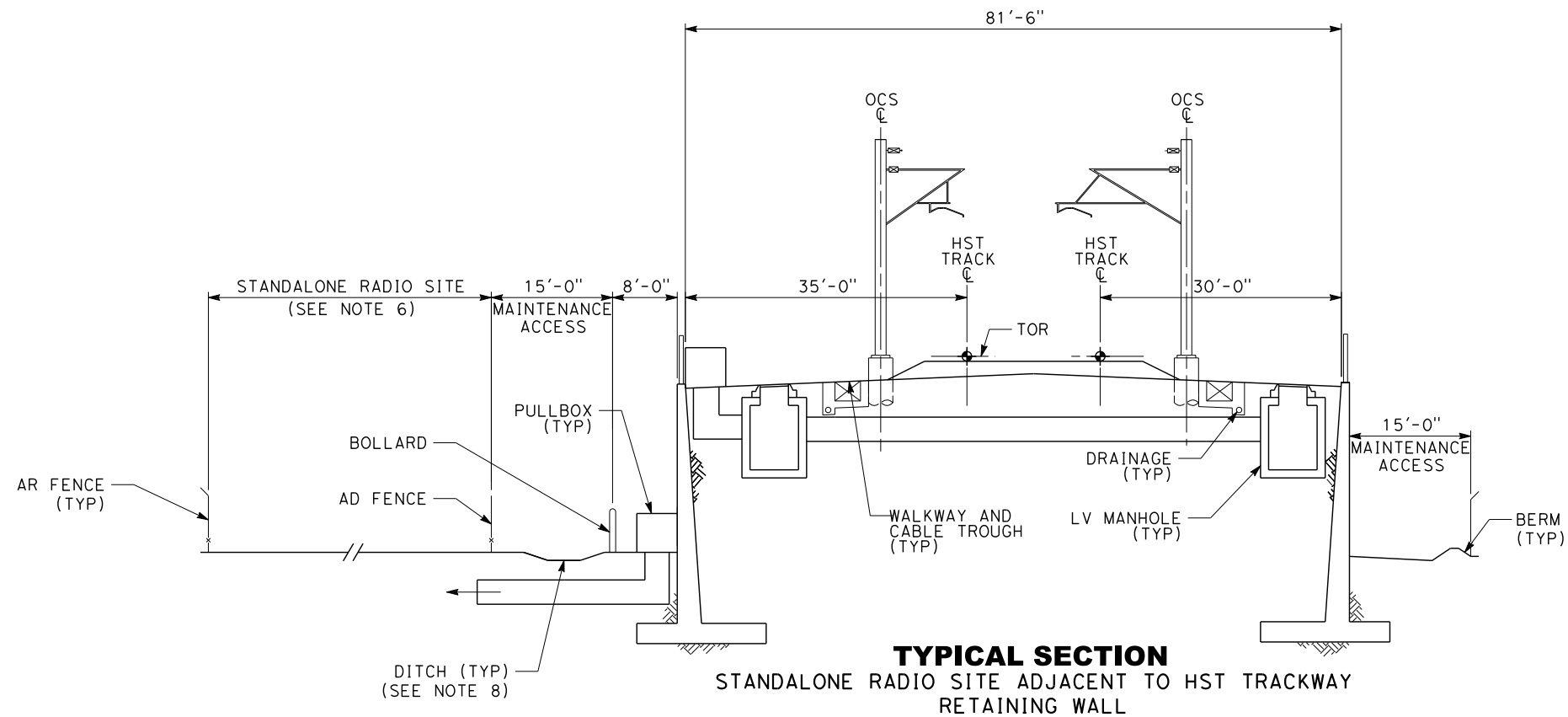

TYPICAL SECTION
STANDALONE RADIO SITE ADJACENT TO HST TRACKWAY
RETAINING WALL

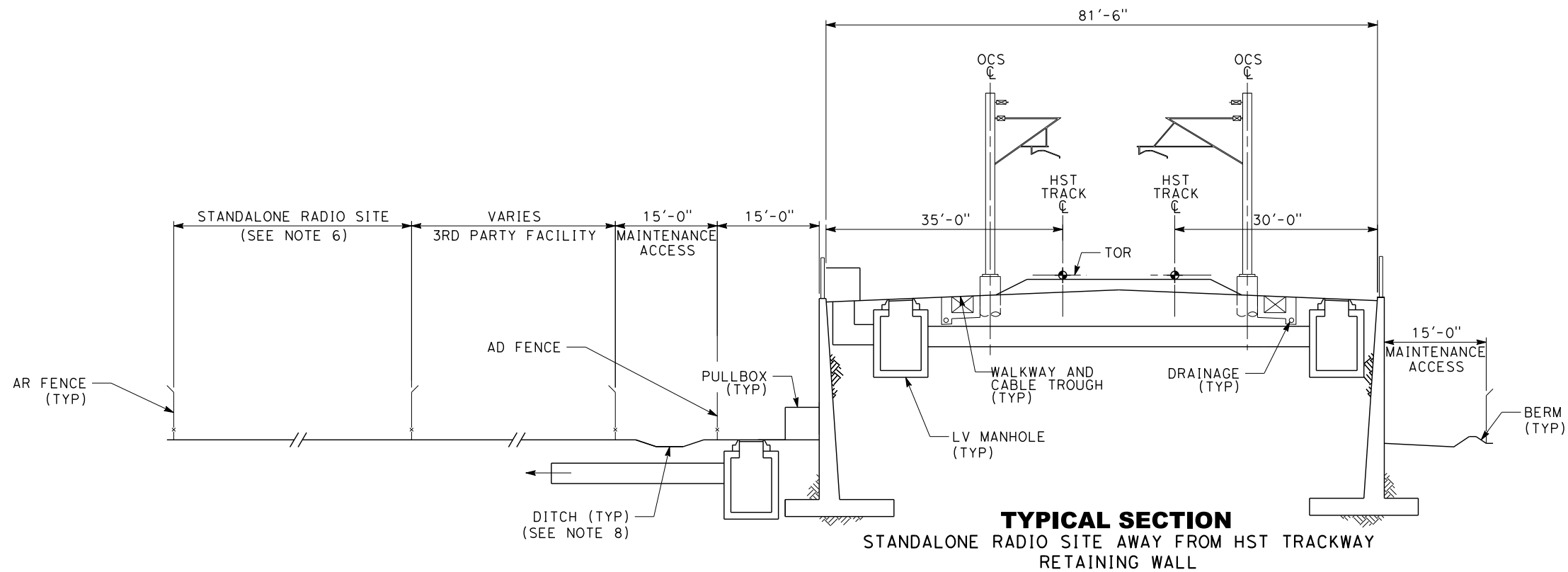

TYPICAL SECTION
STANDALONE RADIO SITE AWAY FROM HST TRACKWAY
RETAINING WALL

NOTES:

1. ALL DIMENSIONS ARE SHOWN AS MINIMUM REQUIREMENTS.
2. RIGHT-OF-WAY REQUIRED FOR THE HIGH-SPEED RAIL TRACKWAY WILL DEPEND UPON CONDITIONS ALONG THE ALIGNMENT, INCLUDING TERRAIN, WHERE CUT/FILL SLOPES, RETAINING STRUCTURES, AND ACCESS ARE REQUIRED.
3. SYSTEM SITES ALONG RETAINED-FILL TRACKWAY ARE UNDESIRABLE. THESE CROSS-SECTIONS ARE ONLY APPLICABLE IF AT-GRADE SOLUTION IS DEMONSTRATED TO VIOLATE SITE SPACING REQUIREMENTS OR OTHER CRITICAL CRITERIA.
4. SYSTEM SITES AWAY FROM TRACKWAY ARE UNDESIRABLE. AWAY CROSS-SECTION IS ONLY APPLICABLE IF ADJACENT SOLUTION IS DEMONSTRATED TO VIOLATE SITE SPACING REQUIREMENTS OR OTHER CRITICAL CRITERIA.
5. TYPICAL CROSS-SECTIONAL WIDTH SHOWN SHALL BE PROVIDED FOR MINIMUM LENGTH EQUAL TO THE LONGITUDINAL WIDTH OF THE SYSTEMS SITE.
6. FOR STANDALONE RADIO SITE REQUIREMENTS REFER TO TM 3.4.2 COMMUNICATIONS SYSTEMS SITE REQUIREMENTS.
7. FOR ACCESS TO TRACKWAY REQUIREMENTS REFER TO TM 2.8.1 SAFETY AND SECURITY DESIGN REQUIREMENTS FOR INFRASTRUCTURE ELEMENTS.
8. FOR DITCH DIMENSIONS REFER TO DRAWING TM 1.1.21-B.
9. FOR RETAINED-FILL TRACKWAYS, REINFORCED CONCRETE RETAINED WALLS SHALL BE USED AT STANDALONE RADIO SITES.

8/13/2013 2:30:52 PM C:\Users\huante\Desktop\wise\1.1.21-N.dgn

REV	DATE	BY	CHK	APP	DESCRIPTION

DESIGNED BY A. CHEUNG
DRAWN BY V. HUANTE
CHECKED BY S. MILITELLO
IN CHARGE G. LUSHEROVICH
DATE 08/13/2013



CALIFORNIA HIGH-SPEED TRAIN PROJECT
TECHNICAL MEMORANDUM

SYSTEMS SITE
STANDALONE RADIO SITE
RETAINED-FILL

CONTRACT NO.
DRAWING NO. TM 1.1.21-N
SCALE NO SCALE
SHEET NO.

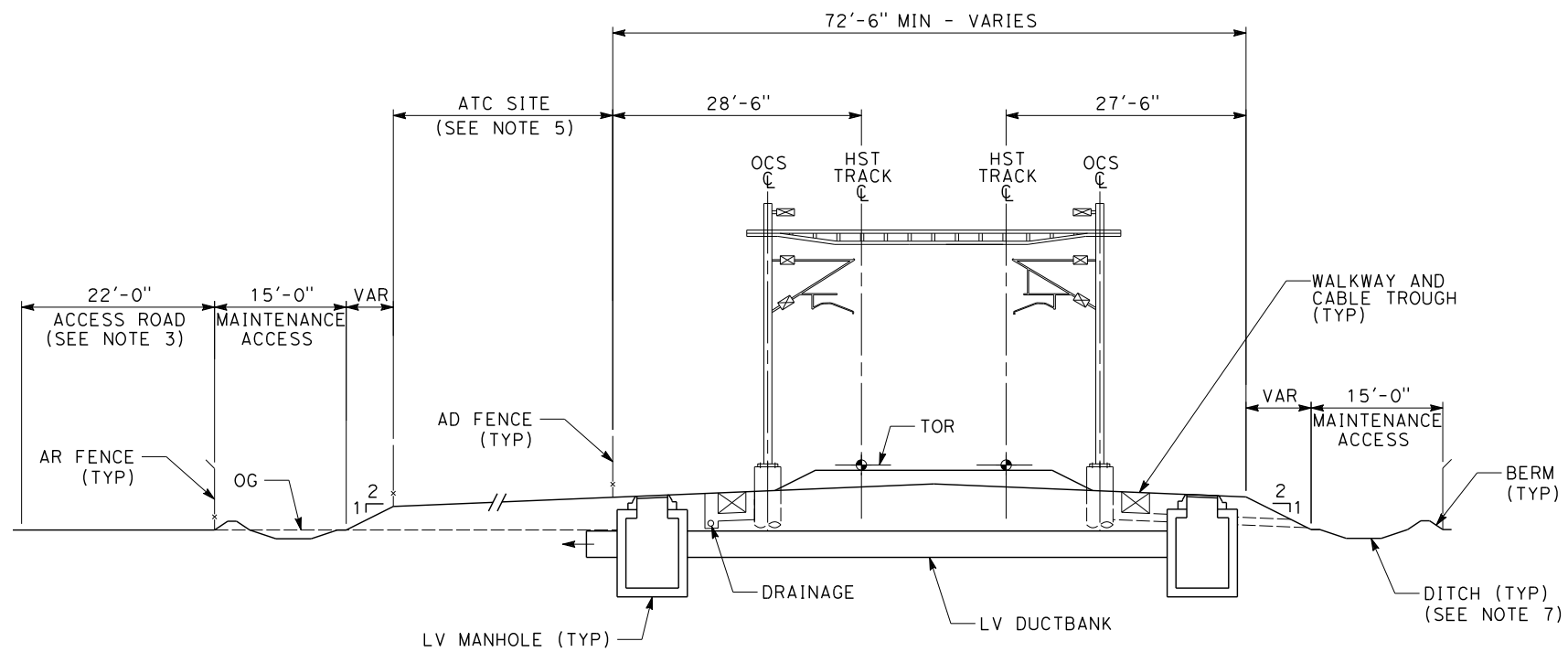

TYPICAL SECTION
ATC SITE ADJACENT TO AT-GRADE HST TRACKWAY

NOTES:

1. ALL DIMENSIONS ARE SHOWN AS MINIMUM REQUIREMENTS.
2. RIGHT-OF-WAY REQUIRED FOR THE HIGH-SPEED RAIL TRACKWAY WILL DEPEND UPON CONDITIONS ALONG THE ALIGNMENT, INCLUDING TERRAIN, WHERE CUT/FILL SLOPES, RETAINING STRUCTURES, AND ACCESS ARE REQUIRED.
3. ACCESS ROAD CONNECTING ATC SITE A WITH ATC SITE B GOING CONTINUOUS ALONG THE RIGHT-OF-WAY OUTSIDE THE FENCE LINE IS PREFERRED BUT NOT MANDATORY. ACCESS ROADS TO ALL SITES MUST BE PROVIDED AS PER TM 3.3.2.
4. CROSS-SECTIONAL WIDTH SHOWN SHALL BE PROVIDED FOR THE LONGITUDINAL LENGTH OF THE CROSSOVERS AND 100 FEET BEYOND THE FURTHEST POINTS OF SWITCH.
5. FOR ATC SITE REQUIREMENTS REFER TO TM 3.3.2 AUTOMATIC TRAIN CONTROL SITE REQUIREMENTS.
6. FOR ACCESS TO TRACKWAY REQUIREMENTS REFER TO TM 2.8.1 SAFETY AND SECURITY DESIGN REQUIREMENTS FOR INFRASTRUCTURE ELEMENTS.
7. FOR V-DITCH AND DITCH DIMENSIONS REFER TO DRAWING TM 1.1.21-B.

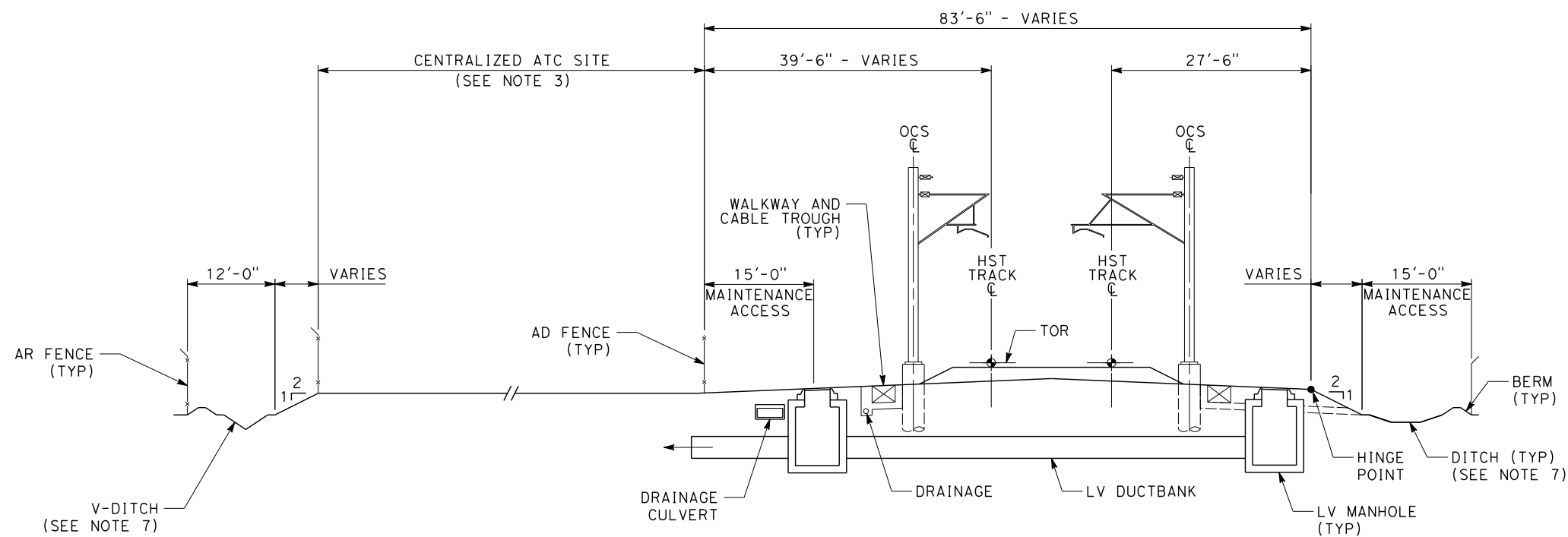

TYPICAL SECTION
CENTRALIZED ATC SITE ADJACENT TO AT-GRADE HST TRACKWAY

8/13/2013 2:30:54 PM CAHSR.TBL CHSR_half_black.plt C:\Users\huante\Desktop\wise\1.1.21-0.dgn

REV	DATE	BY	CHK	APP	DESCRIPTION

DESIGNED BY
A. CHEUNG
DRAWN BY
V. HUANTE
CHECKED BY
S. MILITELLO
IN CHARGE
G. LUSHEROVICH
DATE
08/13/2013



CALIFORNIA HIGH-SPEED TRAIN PROJECT
TECHNICAL MEMORANDUM

SYSTEMS SITE
ATC SITES
AT-GRADE

CONTRACT NO.
DRAWING NO.
TM 1.1.21-0
SCALE
NO SCALE
SHEET NO.

NOTES:

1. ALL DIMENSIONS ARE SHOWN AS MINIMUM REQUIREMENTS.
2. RIGHT-OF-WAY REQUIRED FOR THE HIGH-SPEED RAIL TRACKWAY WILL DEPEND UPON CONDITIONS ALONG THE ALIGNMENT, INCLUDING TERRAIN, WHERE CUT/FILL SLOPES, RETAINING STRUCTURES, AND ACCESS ARE REQUIRED.
3. SYSTEM SITES ALONG AERIAL TRACKWAY ARE UNDESIRABLE. THESE CROSS-SECTIONS ARE ONLY APPLICABLE IF AT-GRADE SOLUTION IS DEMONSTRATED TO VIOLATE SITE SPACING REQUIREMENTS OR OTHER CRITICAL CRITERIA.
4. CROSS-SECTIONAL WIDTH SHOWN SHALL BE PROVIDED FOR THE LONGITUDINAL LENGTH OF THE Crossovers AND 100 FEET BEYOND THE FURTHEST POINTS OF SWITCH.
5. FOR ATC SITE REQUIREMENTS REFER TO TM 3.3.2 AUTOMATIC TRAIN CONTROL SITE REQUIREMENTS.
6. FOR ACCESS TO TRACKWAY REQUIREMENTS REFER TO TM 2.8.1 SAFETY AND SECURITY DESIGN REQUIREMENTS FOR INFRASTRUCTURE ELEMENTS.

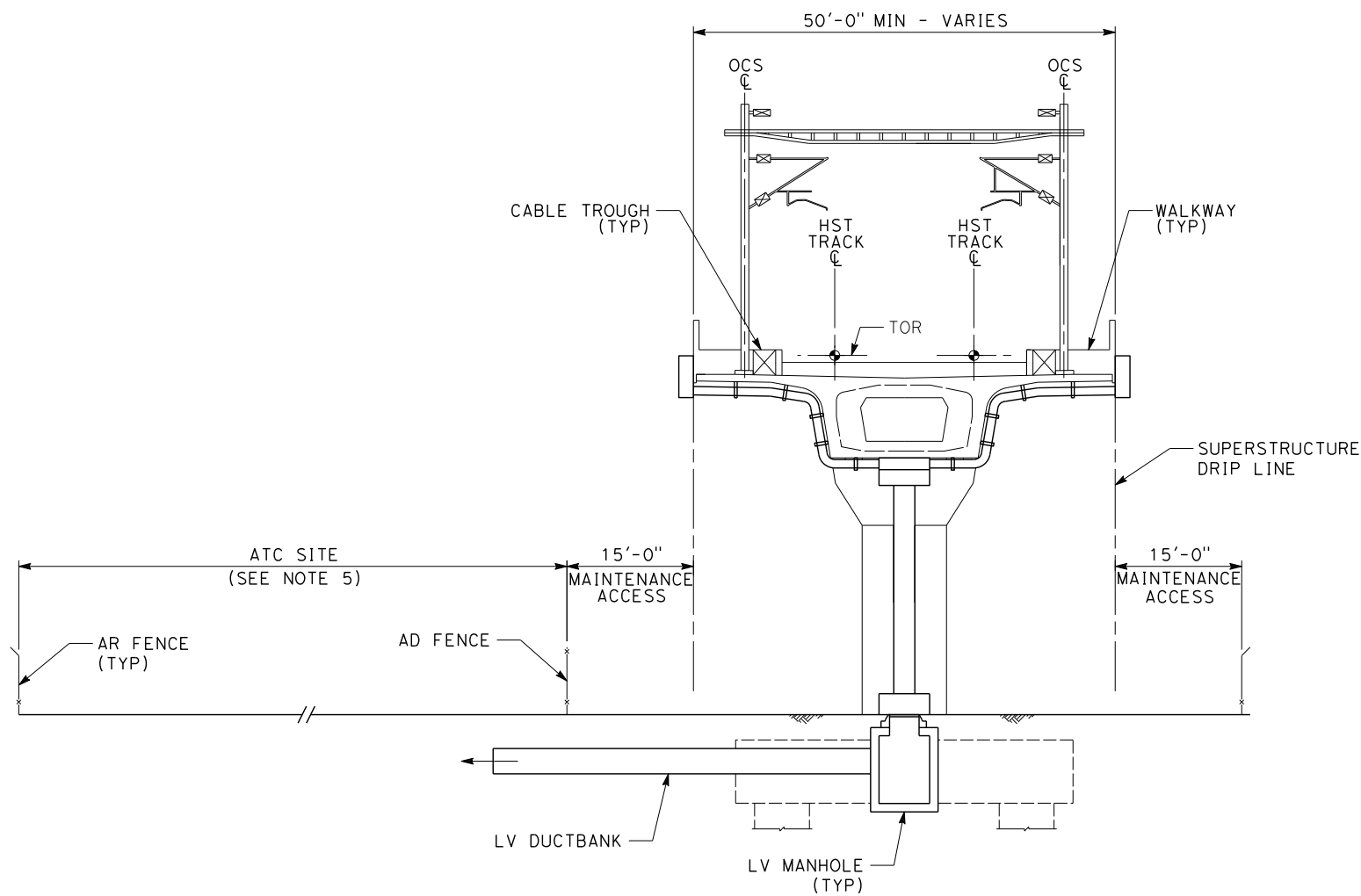

TYPICAL SECTION
ATC SITE AT AERIAL TRACKWAY

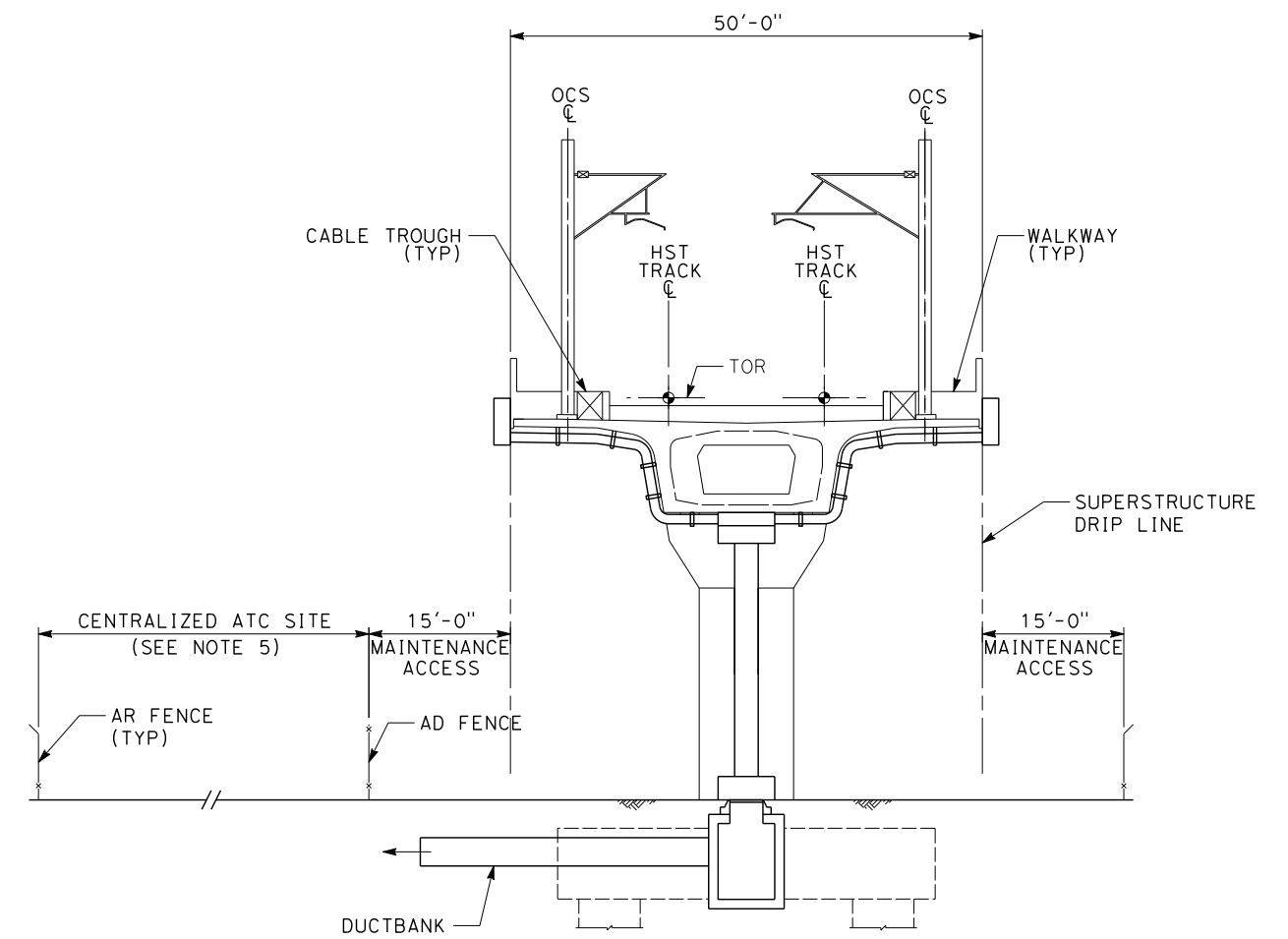

TYPICAL SECTION
CENTRALIZED ATC SITE AT AERIAL TRACKWAY

8/13/2013 2:30:56 PM huante C:\Users\huante\Desktop\wise\1.1.21-P.dgn CAHSR.TBL CHSR_half_black.plt

REV	DATE	BY	CHK	APP	DESCRIPTION

DESIGNED BY
A. CHEUNG
 DRAWN BY
V. HUANTE
 CHECKED BY
S. MILITELLO
 IN CHARGE
G. LUSHEROVICH
 DATE
08/13/2013



CALIFORNIA HIGH-SPEED TRAIN PROJECT
TECHNICAL MEMORANDUM

SYSTEMS SITE
ATC SITES
AERIAL

CONTRACT NO.
DRAWING NO.
TM 1.1.21-P
SCALE
NO SCALE
SHEET NO.

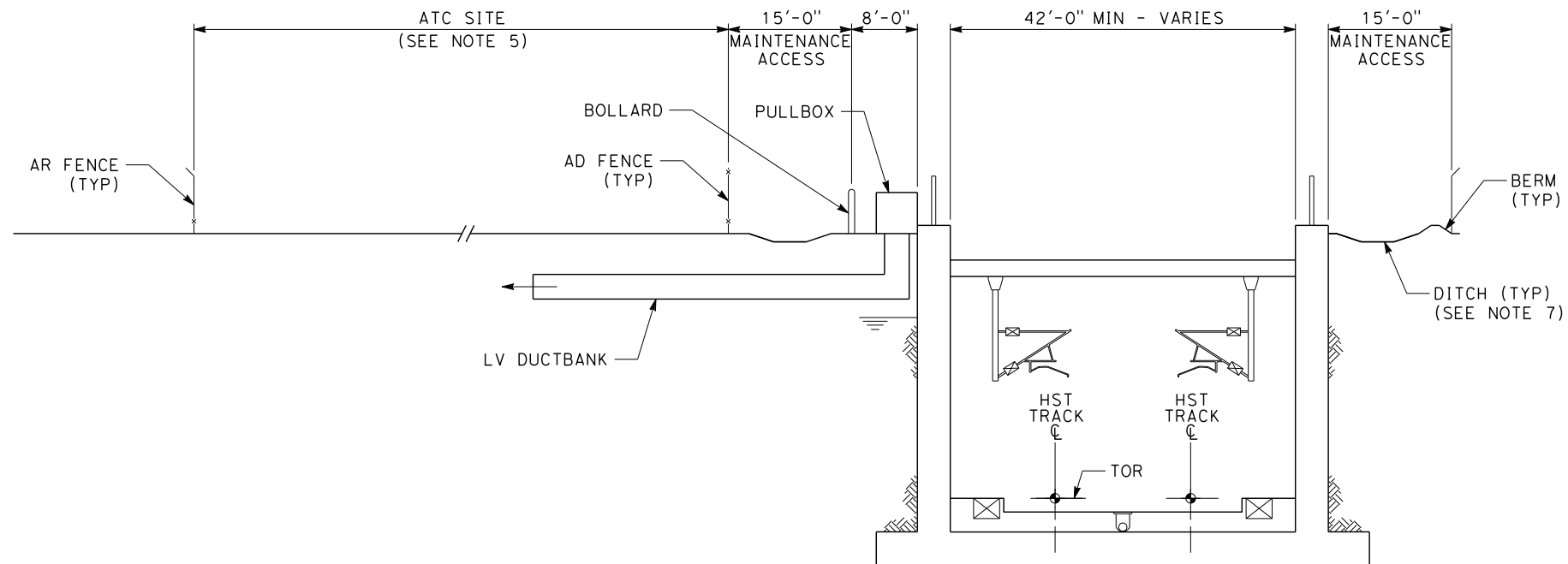

TYPICAL SECTION
ATC SITE ADJACENT TO HST TRACKWAY
TRENCH

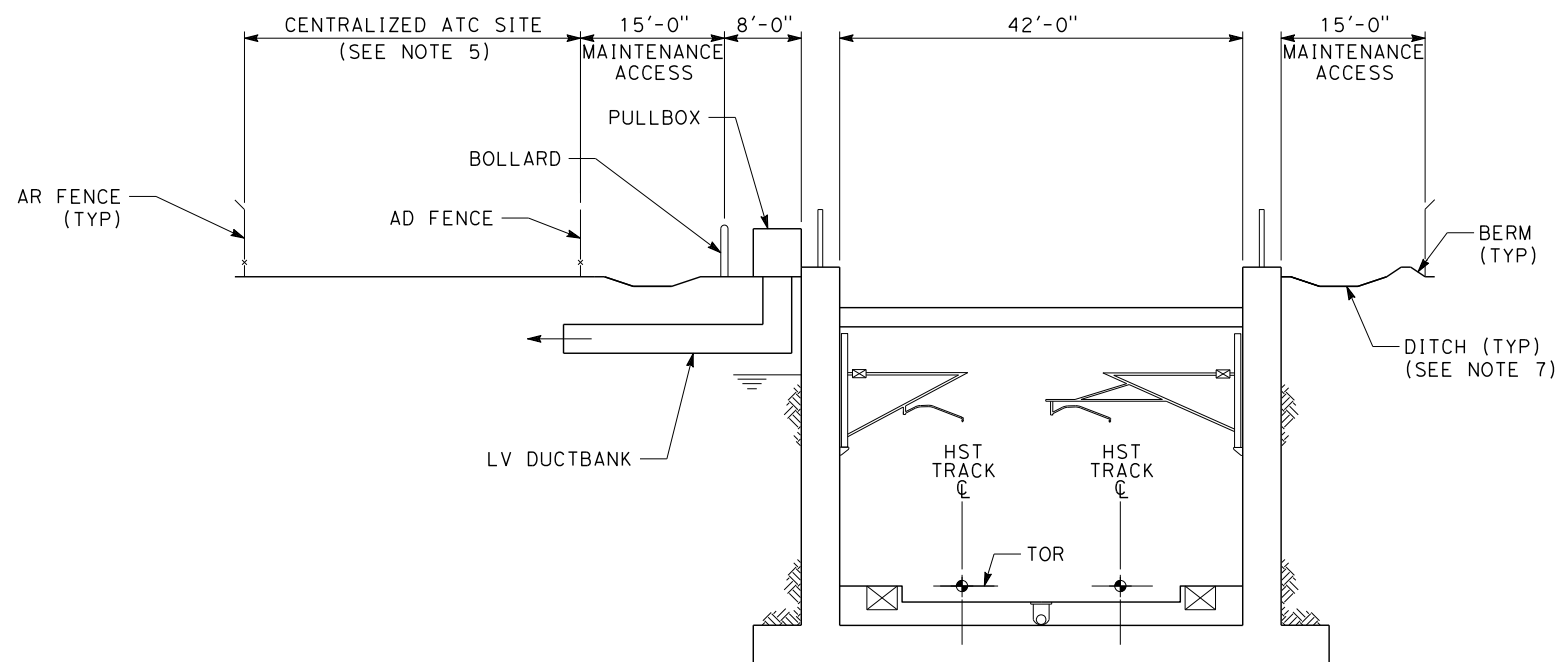

TYPICAL SECTION
CENTRALIZED ATC SITE ADJACENT TO TRENCH HST TRACKWAY

NOTES:

1. ALL DIMENSIONS ARE SHOWN AS MINIMUM REQUIREMENTS.
2. RIGHT-OF-WAY REQUIRED FOR THE HIGH-SPEED RAIL TRACKWAY WILL DEPEND UPON CONDITIONS ALONG THE ALIGNMENT, INCLUDING TERRAIN, WHERE CUT/FILL SLOPES, RETAINING STRUCTURES, AND ACCESS ARE REQUIRED.
3. SYSTEM SITES ALONG TRENCH TRACKWAY ARE UNDESIRABLE. THESE CROSS-SECTIONS ARE ONLY APPLICABLE IF AT-GRADE SOLUTION IS DEMONSTRATED TO VIOLATE SITE SPACING REQUIREMENTS OR OTHER CRITICAL CRITERIA.
4. CROSS-SECTIONAL WIDTH SHOWN SHALL BE PROVIDED FOR THE LONGITUDINAL LENGTH OF THE CROSSOVERS AND 100 FEET BEYOND THE FURTHEST POINTS OF SWITCH.
5. FOR ATC SITE REQUIREMENTS REFER TO TM 3.3.2 AUTOMATIC TRAIN CONTROL SITE REQUIREMENTS.
6. FOR ACCESS TO TRACKWAY REQUIREMENTS REFER TO TM 2.8.1 SAFETY AND SECURITY DESIGN REQUIREMENTS FOR INFRASTRUCTURE ELEMENTS.
7. FOR DITCH DIMENSIONS REFER TO DRAWING TM 1.1.21-B.

8/13/2013 2:30:57 PM C:\Users\huante\Desktop\wise\1.1.21-0.dgn CAHSR.TBL CHSR_half_black.plt

REV	DATE	BY	CHK	APP	DESCRIPTION

DESIGNED BY
A. CHEUNG
 DRAWN BY
V. HUANTE
 CHECKED BY
S. MILITELLO
 IN CHARGE
G. LUSHEROVICH
 DATE
08/13/2013

--	--	--	--



CALIFORNIA HIGH-SPEED TRAIN PROJECT
TECHNICAL MEMORANDUM

 SYSTEMS SITE
 ATC SITE
 TRENCH

CONTRACT NO.	
DRAWING NO.	TM 1.1.21-0
SCALE	NO SCALE
SHEET NO.	

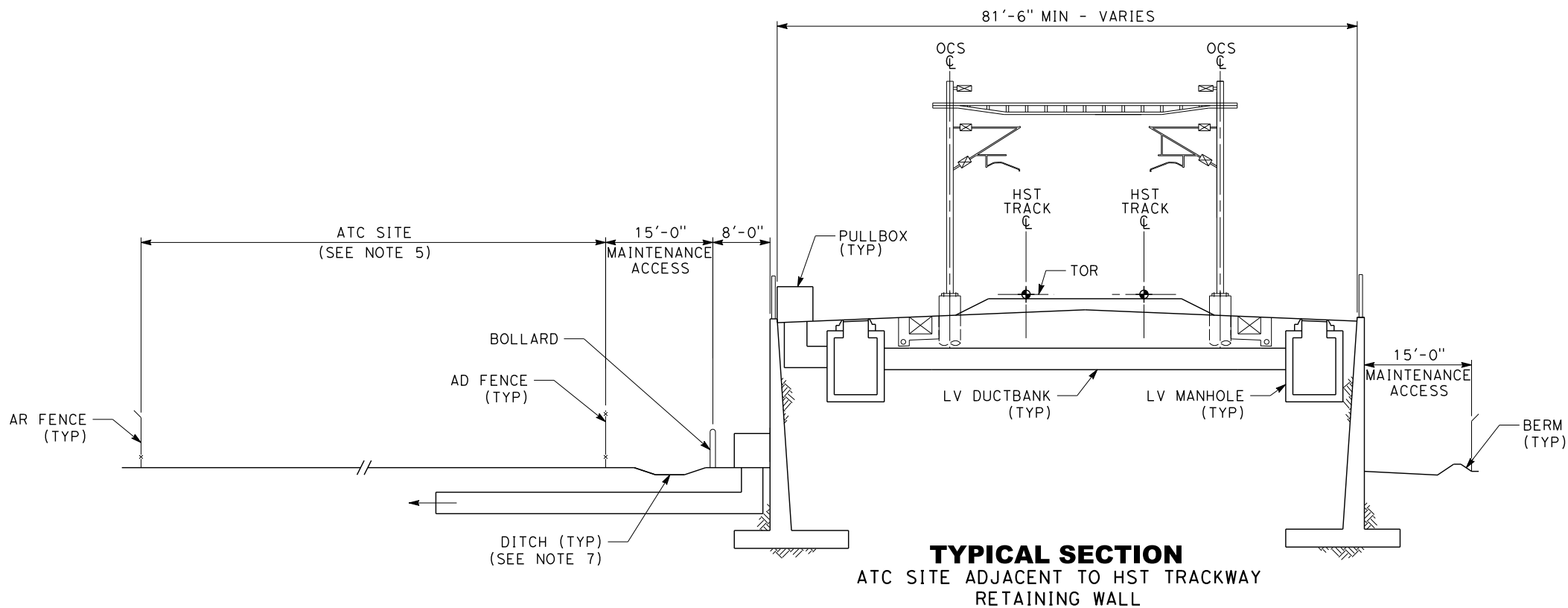

- NOTES:**
1. ALL DIMENSIONS ARE SHOWN AS MINIMUM REQUIREMENTS.
 2. RIGHT-OF-WAY REQUIRED FOR THE HIGH-SPEED RAIL TRACKWAY WILL DEPEND UPON CONDITIONS ALONG THE ALIGNMENT, INCLUDING TERRAIN, WHERE CUT/FILL SLOPES, RETAINING STRUCTURES, AND ACCESS ARE REQUIRED.
 3. SYSTEM SITES ALONG RETAINED-FILL TRACKWAY ARE UNDESIRE. THESE CROSS-SECTIONS ARE ONLY APPLICABLE IF AT-GRADE SOLUTION IS DEMONSTRATED TO VIOLATE SITE SPACING REQUIREMENTS OR OTHER CRITICAL CRITERIA.
 4. CROSS-SECTIONAL WIDTH SHOWN SHALL BE PROVIDED FOR THE LONGITUDINAL LENGTH OF THE CROSSOVERS AND 100 FEET BEYOND THE FURTHEST POINTS OF SWITCH.
 5. FOR ATC SITE REQUIREMENTS REFER TO TM 3.3.2 AUTOMATIC TRAIN CONTROL SITE REQUIREMENTS.
 6. FOR ACCESS TO TRACKWAY REQUIREMENTS REFER TO TM 2.8.1 SAFETY AND SECURITY DESIGN REQUIREMENTS FOR INFRASTRUCTURE ELEMENTS.
 7. FOR DITCH DIMENSIONS REFER TO DRAWING TM 1.1.21-B.
 8. FOR RETAINED-FILL TRACKWAYS, REINFORCED CONCRETE RETAINING WALLS SHALL BE USED AT ATC SITES.

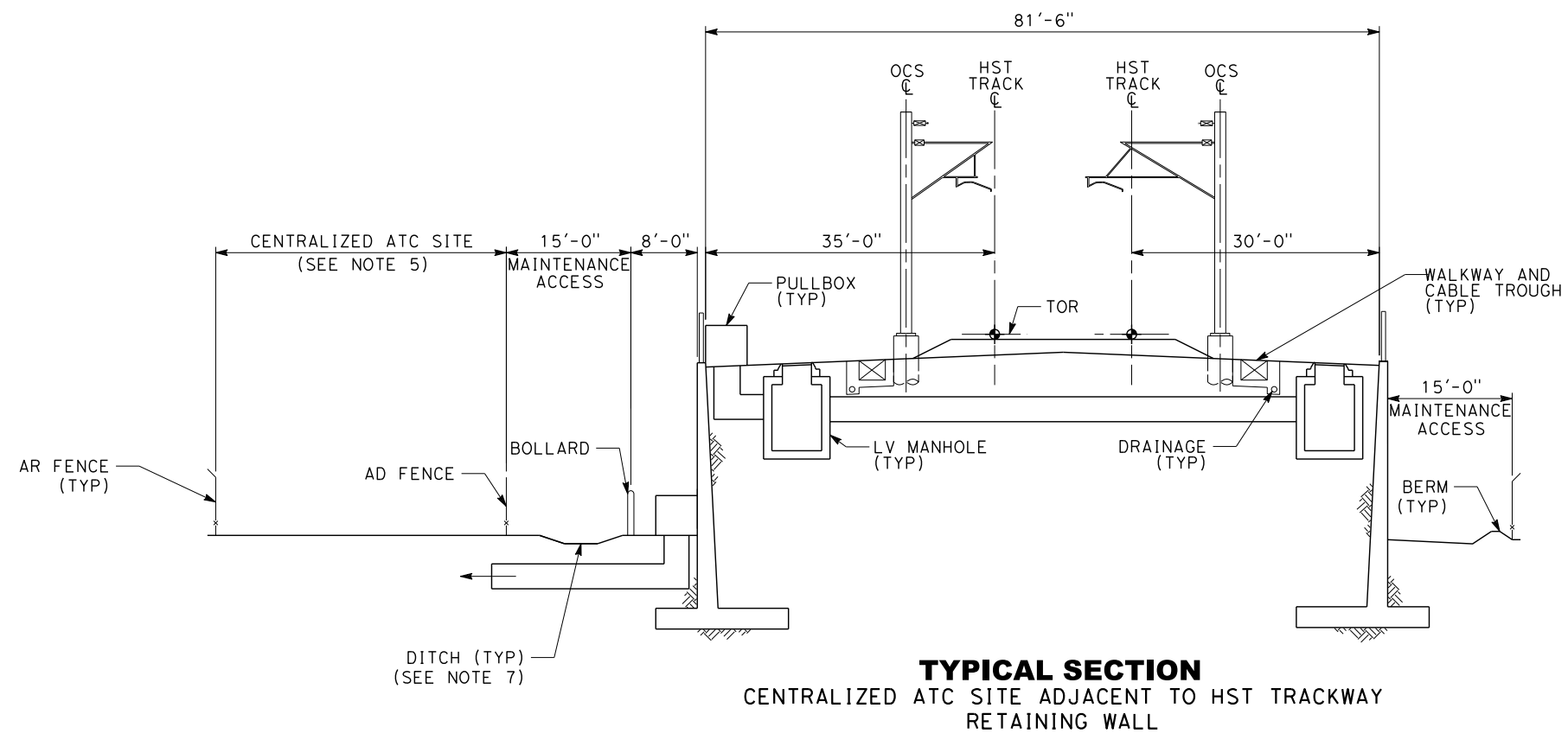

8/13/2013 2:30:59 PM CAHSRP.tbl CHSR_half_black.plt C:\Users\huante\Desktop\wise\1.1.21-R.dgn

REV	DATE	BY	CHK	APP	DESCRIPTION

DESIGNED BY
A. CHEUNG
DRAWN BY
V. HUANTE
CHECKED BY
S. MILITELLO
IN CHARGE
G. LUSHEROVICH
DATE
08/13/2013

--	--	--	--



CALIFORNIA HIGH-SPEED TRAIN PROJECT
TECHNICAL MEMORANDUM

SYSTEMS SITE
ATC SITES
RETAINED-FILL

CONTRACT NO.	
DRAWING NO.	TM 1.1.21-R
SCALE	NO SCALE
SHEET NO.	

August 20, 2013

PMT-CHSRA-03636

Frank Vacca
Chief Program Manager
California High-Speed Rail Authority
770 L Street, Suite 800
Sacramento, CA 95814

RE: Request for Authority review and concurrence of
TM 1.1.21 Typical Cross Sections for 15% Design, R1

Mr. Vacca,

Technical Memorandum (TM) 1.1.21 *Typical Cross Sections for 15% Design* was originally issued in April 2009. The primary purpose of the TM was to define conceptual cross sections to be used by Regional Consultants in advancing the 15% Design as required to support the project-specific EIR/EIS process.

TM 1.1.21, R1 has been revised to include the following primary updates to the cross sections:

- Incorporate systems facilities requirements and their spatial relationship with track and other infrastructure elements
- Introduction of maintenance access requirements
- Promote the use of open drainage along the alignment
- Provide clarification that the project footprint should be established based on site-specific application of project requirements rather than using a fixed width at all locations

The original cross sections were developed based on a procurement strategy that anticipated that the infrastructure and systems facilities would be designed and constructed by a single contractor. The revised sections reflect the current procurement approach that constructs the high-speed train system in multiple contracts and provides for tolerances for the phased construction.

Similarly, the original cross sections anticipated a conceptual maintenance strategy whereby the infrastructure and systems facilities would be maintained primarily from within the right-of-way using rail-based vehicles. The revised sections reflect the current procurement approach that defers construction of maintenance facilities to subsequent stages of the construction and promotes the use of rubber-tire vehicles for many of the inspection and maintenance activities.

The revised cross sections also reflect updated infrastructure and systems requirements based on input from adjacent freight railroad operators and lessons learned through the development of the preliminary engineering and environmental assessment for the project's first construction section. Review of the preliminary design used in procurement for Construction Package 1 indicated that additional coordination was required for the systems interfaces with the design of the infrastructure. Systems spatial requirements were not fully considered during the 15% Design and the definition of the project footprint required modification.

This is a living document, and it will be updated as required. If this meets with your requirements, please sign below acknowledging your concurrence for adoption and use on the program.

Regards,

Teri O. Zink, P.E.
Interim Program Director

California High-Speed Rail Authority
Concurrence

Frank Vacca, Chief Program Manager

Date: 8/21/2013

Enclosure: TM 1.1.21 Typical Cross Sections for 15% Design, R1



SIGNATURE/APPROVAL ROUTING SHEET

DOCUMENT(S) INFORMATION
To: Geny Baldini-Koutchis
From: Kris Livingston
Subject: TM 1.1.21 Typical Cross Sections for 15% Design, R1
Description of Enclosed Document(s): The Technical Memo 1.1.21 Typical Cross Sections for 15% Design, R1 is attached for your review and concurrence. I've attached the Initial Release version 0 for reference.
<input type="checkbox"/> Expedite Due Date: .

REVIEWER INFORMATION		
Reviewer #1 Name (Print): Frank Vacca	Reviewer's Initial/Date: <i>FV</i> 8/21/13	Comments:
Reviewer #2 Name (Print):	Reviewer's Initial/Date:	Comments:
Reviewer #3 Name (Print):	Reviewer's Initial/Date:	Comments:
Reviewer #4 Name (Print):	Reviewer's Initial/Date:	Comments:
Reviewer #5 Name (Print):	Reviewer's Initial/Date:	Comments:

- | | |
|---|--|
| <input type="checkbox"/> Approval/Signoff (initials) | <input type="checkbox"/> Information |
| <input checked="" type="checkbox"/> Signature | <input type="checkbox"/> Do Not Release – Call When Signed |
| <input checked="" type="checkbox"/> Hand Carry or Call for Pick up
Name: Kris Livingston Ext.: 9515 | <input type="checkbox"/> Release When Signed |

Executive Office Control No.:	Name of Contact Person:
	Phone Number:
	Office:
	Office Control No.: