

Bakersfield to Palmdale

**Record Set Submittal
Refined Cesar Chavez National Monument (CCNM) Design Option**

**Drawings Addendum
Preliminary Engineering for Project Definition – January 2020**

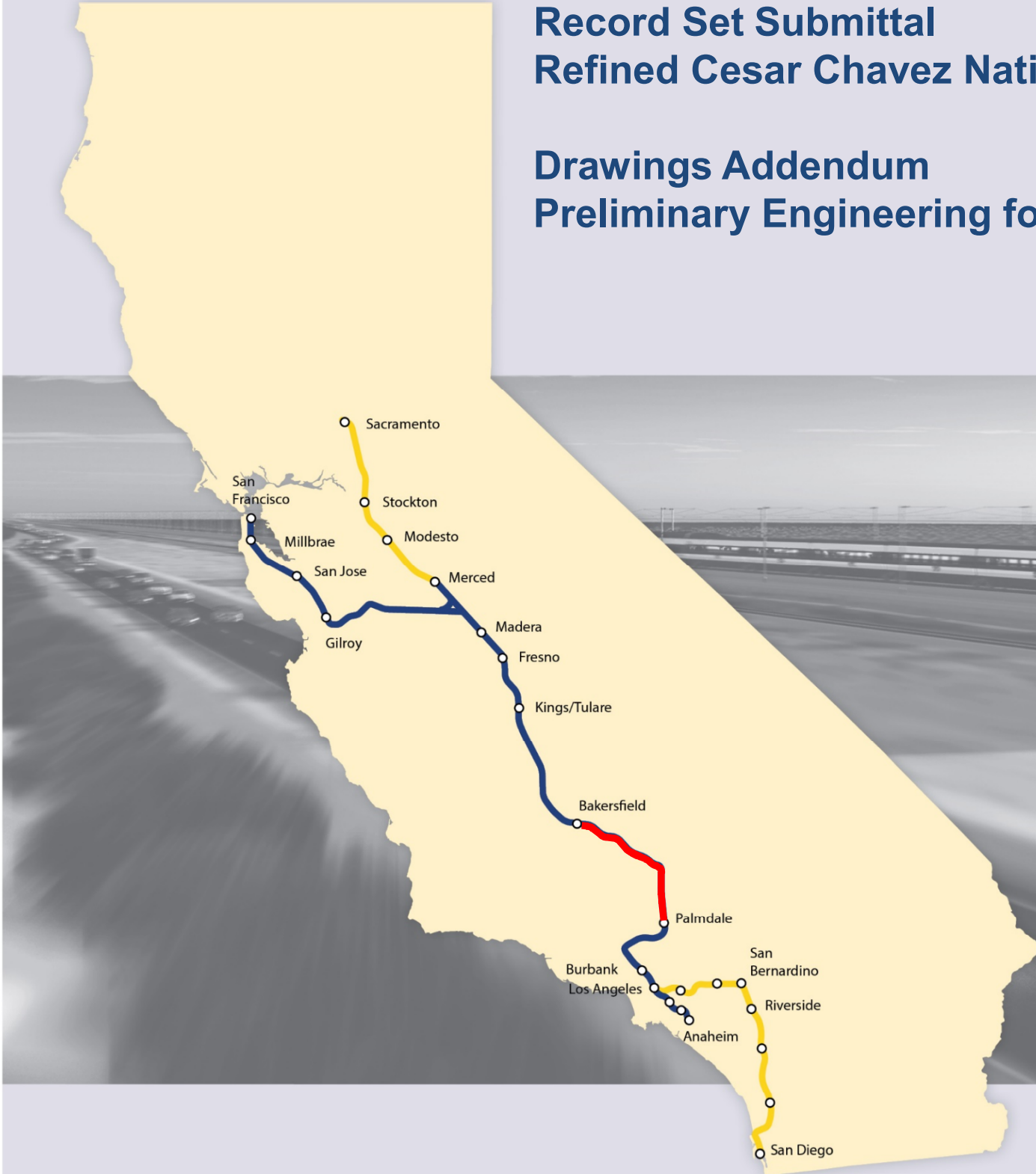

GENERAL SHEETS

DRAWING No.	DRAWING DESCRIPTION
GE-B0102	REFINED CCNM DESIGN OPTION - GENERAL - INDEX OF DRAWING - SHEET 1 OF 3
GE-B0103	REFINED CCNM DESIGN OPTION - GENERAL - INDEX OF DRAWING - SHEET 2 OF 3
GE-B0104	REFINED CCNM DESIGN OPTION - GENERAL - INDEX OF DRAWING - SHEET 3 OF 3
GE-B0105	REFINED CCNM DESIGN OPTION - GENERAL - ABBREVIATIONS - SHEET 1 OF 3
GE-B0106	REFINED CCNM DESIGN OPTION - GENERAL - ABBREVIATIONS - SHEET 2 OF 3
GE-B0107	REFINED CCNM DESIGN OPTION - GENERAL - ABBREVIATIONS - SHEET 3 OF 3

ALIGNMENT

DRAWING No.	DRAWING DESCRIPTION
TT-B0201	REFINED CCNM DESIGN OPTION - TRACK GENERAL - SYMBOLS, LEGEND, AND GENERAL NOTES
TT-B0202	REFINED CCNM DESIGN OPTION - TRACK GENERAL - HORIZONTAL ALIGNMENT DATA TABLE
TT-B3201	REFINED CCNM DESIGN OPTION - TRACK GENERAL - TYPICAL SECTIONS - SHEET 1 OF 10
TT-B3202	REFINED CCNM DESIGN OPTION - TRACK GENERAL - TYPICAL SECTIONS - SHEET 2 OF 10
TT-B3203	REFINED CCNM DESIGN OPTION - TRACK GENERAL - TYPICAL SECTIONS - SHEET 3 OF 10
TT-B3204	REFINED CCNM DESIGN OPTION - TRACK GENERAL - TYPICAL SECTIONS - SHEET 4 OF 10
TT-B3205	REFINED CCNM DESIGN OPTION - TRACK GENERAL - TYPICAL SECTIONS - SHEET 5 OF 10
TT-B3206	REFINED CCNM DESIGN OPTION - TRACK GENERAL - TYPICAL SECTIONS - SHEET 6 OF 10
TT-B3207	REFINED CCNM DESIGN OPTION - TRACK GENERAL - TYPICAL SECTIONS - SHEET 7 OF 10
TT-B3208	REFINED CCNM DESIGN OPTION - TRACK GENERAL - TYPICAL SECTIONS - SHEET 8 OF 10
TT-B3209	REFINED CCNM DESIGN OPTION - TRACK GENERAL - TYPICAL SECTIONS - SHEET 9 OF 10
TT-B3210	REFINED CCNM DESIGN OPTION - TRACK GENERAL - TYPICAL SECTIONS - SHEET 10 OF 10
TT-C6201	REFINED CCNM DESIGN OPTION - TRACK GENERAL - KEY MAP
TT-D1401	REFINED CCNM DESIGN OPTION - TRACK GUIDEWAY - STA 18275+00 TO 18325+00 - PLAN AND PROFILE
TT-D1402	REFINED CCNM DESIGN OPTION - TRACK GUIDEWAY - STA 18325+00 TO 18375+00 - PLAN AND PROFILE
TT-D1403	REFINED CCNM DESIGN OPTION - TRACK GUIDEWAY - STA 18375+00 TO 18425+00 - PLAN AND PROFILE
TT-D1404	REFINED CCNM DESIGN OPTION - TRACK GUIDEWAY - STA 18425+00 TO 18475+00 - PLAN AND PROFILE
TT-D1405	REFINED CCNM DESIGN OPTION - TRACK GUIDEWAY - STA 18475+00 TO 18525+00 - PLAN AND PROFILE
TT-D1406	REFINED CCNM DESIGN OPTION - TRACK GUIDEWAY - STA 18525+00 TO 18575+00 - PLAN AND PROFILE
TT-D1407	REFINED CCNM DESIGN OPTION - TRACK GUIDEWAY - STA 18575+00 TO 18625+00 - PLAN AND PROFILE
TT-D1408	REFINED CCNM DESIGN OPTION - TRACK GUIDEWAY - STA 18625+00 TO 18675+00 - PLAN AND PROFILE
TT-D1409	REFINED CCNM DESIGN OPTION - TRACK GUIDEWAY - STA 18675+00 TO 18725+00 - PLAN AND PROFILE
TT-D1410	REFINED CCNM DESIGN OPTION - TRACK GUIDEWAY - STA 18725+00 TO 18775+00 - PLAN AND PROFILE
TT-D1411	REFINED CCNM DESIGN OPTION - TRACK GUIDEWAY - STA 18775+00 TO 18825+00 - PLAN AND PROFILE
TT-D1412	REFINED CCNM DESIGN OPTION - TRACK GUIDEWAY - STA 18825+00 TO 18875+00 - PLAN AND PROFILE
TT-D1413	REFINED CCNM DESIGN OPTION - TRACK GUIDEWAY - STA 18875+00 TO 18925+00 - PLAN AND PROFILE
TT-D1414	REFINED CCNM DESIGN OPTION - TRACK GUIDEWAY - STA 18925+00 TO 18975+00 - PLAN AND PROFILE
TT-D1415	REFINED CCNM DESIGN OPTION - TRACK GUIDEWAY - STA 18975+00 TO 19025+00 - PLAN AND PROFILE
TT-D1416	REFINED CCNM DESIGN OPTION - TRACK GUIDEWAY - STA 19025+00 TO 19075+00 - PLAN AND PROFILE
TT-D1417	REFINED CCNM DESIGN OPTION - TRACK GUIDEWAY - STA 19075+00 TO 19115+00 - PLAN AND PROFILE

ROADWAY

DRAWING No.	DRAWING DESCRIPTION
CV-R0101	REFINED CCNM DESIGN OPTION - ROADWAY GENERAL - SYMBOLS, LEGEND, AND GENERAL NOTES
CV-R0102	REFINED CCNM DESIGN OPTION - ROADWAY GENERAL - TYPICAL SECTIONS - SHEET 1 OF 2
CV-R0103	REFINED CCNM DESIGN OPTION - ROADWAY GENERAL - TYPICAL SECTIONS - SHEET 2 OF 2
CV-R0104	REFINED CCNM DESIGN OPTION - ROADWAY GENERAL - KEY MAP
CV-R1601	REFINED CCNM DESIGN OPTION - ROADWAY - ACCESS ROAD "18457" - HORIZONTAL ALIGNMENT DATA TABLE
CV-R1602	REFINED CCNM DESIGN OPTION - ROADWAY - ACCESS ROAD "18457" - PLAN AND PROFILE
CV-R1603	REFINED CCNM DESIGN OPTION - ROADWAY - ACCESS ROAD "18487" - PLAN AND PROFILE
CV-R1604	REFINED CCNM DESIGN OPTION - ROADWAY - DIRT ROAD "18492" - PLAN AND PROFILE
CV-R1605	REFINED CCNM DESIGN OPTION - ROADWAY - ACCESS ROAD "18507" - HORIZONTAL ALIGNMENT DATA TABLE
CV-R1606	REFINED CCNM DESIGN OPTION - ROADWAY - ACCESS ROAD "18507" - PLAN AND PROFILE - SHEET 1 OF 2
CV-R1607	REFINED CCNM DESIGN OPTION - ROADWAY - ACCESS ROAD "18507" - PLAN AND PROFILE - SHEET 2 OF 2

ROADWAY

DRAWING No.	DRAWING DESCRIPTION
CV-R1608	REFINED CCNM DESIGN OPTION - ROADWAY - DIRT ROAD "18567" - PLAN AND PROFILE
CV-R1609	REFINED CCNM DESIGN OPTION - ROADWAY - ACCESS ROAD "18601" - HORIZONTAL ALIGNMENT DATA TABLE
CV-R1610	REFINED CCNM DESIGN OPTION - ROADWAY - ACCESS ROAD "18601" - PLAN AND PROFILE - SHEET 1 OF 2
CV-R1611	REFINED CCNM DESIGN OPTION - ROADWAY - ACCESS ROAD "18601" - PLAN AND PROFILE - SHEET 2 OF 2
CV-R1612	REFINED CCNM DESIGN OPTION - ROADWAY - ACCESS ROAD "18580" - PLAN AND PROFILE
CV-R1613	REFINED CCNM DESIGN OPTION - ROADWAY - ACCESS ROAD "18580_PS" & "18594" - PLAN AND PROFILE
CV-R1614	REFINED CCNM DESIGN OPTION - ROADWAY - ACCESS ROAD "18607" - PLAN AND PROFILE
CV-R1615	REFINED CCNM DESIGN OPTION - ROADWAY - ACCESS ROAD "18739" - PLAN AND PROFILE
CV-R1616	REFINED CCNM DESIGN OPTION - ROADWAY - ACCESS ROAD "18745" - PLAN AND PROFILE
CV-R1617	REFINED CCNM DESIGN OPTION - ROADWAY - ACCESS ROAD "18920" - PLAN AND PROFILE - SHEET 1 OF 3
CV-R1618	REFINED CCNM DESIGN OPTION - ROADWAY - ACCESS ROAD "18920" - PLAN AND PROFILE - SHEET 2 OF 3
CV-R1619	REFINED CCNM DESIGN OPTION - ROADWAY - ACCESS ROAD "18920" - PLAN AND PROFILE - SHEET 3 OF 3
CV-R1620	REFINED CCNM DESIGN OPTION - ROADWAY - ACCESS ROAD "19065" - PLAN AND PROFILE
CV-R1621	REFINED CCNM DESIGN OPTION - ROADWAY - SR 58 REALIGNMENT - PLAN AND PROFILE - SHEET 1 OF 4
CV-R1622	REFINED CCNM DESIGN OPTION - ROADWAY - SR 58 REALIGNMENT - PLAN AND PROFILE - SHEET 2 OF 4
CV-R1623	REFINED CCNM DESIGN OPTION - ROADWAY - SR 58 REALIGNMENT - PLAN AND PROFILE - SHEET 3 OF 4
CV-R1624	REFINED CCNM DESIGN OPTION - ROADWAY - SR 58 REALIGNMENT - PLAN AND PROFILE - SHEET 4 OF 4
CV-R1625	REFINED CCNM DESIGN OPTION - ROADWAY - SR 58 REALIGNMENT OFF-RAMP - PLAN AND PROFILE
CV-R1626	REFINED CCNM DESIGN OPTION - ROADWAY - SR 58 REALIGNMENT ON-RAMP - PLAN AND PROFILE
CV-R1627	REFINED CCNM DESIGN OPTION - ROADWAY - BURNETT ROAD - PLAN AND PROFILE

CONSTRUCTION SEQUENCING

DRAWING No.	DRAWING DESCRIPTION
CV-I0101	REFINED CCNM DESIGN OPTION - CONSTRUCTION SEQUENCING - GENERAL - NOTES AND LEGEND
CV-I0102	REFINED CCNM DESIGN OPTION - CONSTRUCTION SEQUENCING - GENERAL - KEY MAP
CV-I1201	REFINED CCNM DESIGN OPTION - CONSTRUCTION SEQUENCING - SHEET 1 OF 2
CV-I1202	REFINED CCNM DESIGN OPTION - CONSTRUCTION SEQUENCING - SHEET 2 OF 2

GRADING, DRAINAGE AND RETAINING WALLS

DRAWING No.	DRAWING DESCRIPTION
CV-G0101	REFINED CCNM DESIGN OPTION - GRADING, DRAINAGE AND RETAINING WALLS - GENERAL - LEGEND AND GENERAL NOTES
CV-G0102	REFINED CCNM DESIGN OPTION - GRADING, DRAINAGE AND RETAINING WALLS - GENERAL - KEY MAP
CV-G1501	REFINED CCNM DESIGN OPTION - GRADING AND DRAINAGE - OFFSITE CULVERT PROFILE - STA 18320+92
CV-G1502	REFINED CCNM DESIGN OPTION - GRADING AND DRAINAGE - OFFSITE CULVERT PROFILE - STA 18328+80
CV-G1503	REFINED CCNM DESIGN OPTION - GRADING AND DRAINAGE - OFFSITE CULVERT PROFILE - STA 18352+79
CV-G1504	REFINED CCNM DESIGN OPTION - GRADING AND DRAINAGE - OFFSITE CULVERT PROFILE - STA 18426+67
CV-G1505	REFINED CCNM DESIGN OPTION - GRADING AND DRAINAGE - OFFSITE CULVERT PROFILE - STA 18431+61
CV-G1506	REFINED CCNM DESIGN OPTION - GRADING AND DRAINAGE - OFFSITE CULVERT PROFILE - STA 18433+21
CV-G1507	REFINED CCNM DESIGN OPTION - GRADING AND DRAINAGE - OFFSITE CULVERT PROFILE - STA 18434+43
CV-G1508	REFINED CCNM DESIGN OPTION - GRADING AND DRAINAGE - OFFSITE CULVERT PROFILE - STA 18436+33
CV-G1509	REFINED CCNM DESIGN OPTION - GRADING AND DRAINAGE - OFFSITE CULVERT PROFILE - STA 18442+50
CV-G1510	REFINED CCNM DESIGN OPTION - GRADING AND DRAINAGE - OFFSITE CULVERT PROFILE - STA 18444+31
CV-G1511	REFINED CCNM DESIGN OPTION - GRADING AND DRAINAGE - OFFSITE CULVERT PROFILE - STA 18450+44
CV-G1512	REFINED CCNM DESIGN OPTION - GRADING AND DRAINAGE - OFFSITE CULVERT PROFILE - STA 18460+57
CV-G1513	REFINED CCNM DESIGN OPTION - GRADING AND DRAINAGE - OFFSITE CULVERT PROFILE - STA 18489+32
CV-G1514	REFINED CCNM DESIGN OPTION - GRADING AND DRAINAGE - OFFSITE CULVERT PROFILE - STA 18505+37
CV-G1515	REFINED CCNM DESIGN OPTION - GRADING AND DRAINAGE - OFFSITE CULVERT PROFILE - STA 18510+31
CV-G1516	REFINED CCNM DESIGN OPTION - GRADING AND DRAINAGE - OFFSITE CULVERT PROFILE - STA 18516+71
CV-G1517	REFINED CCNM DESIGN OPTION - GRADING AND DRAINAGE - OFFSITE CULVERT PROFILE - STA 18581+89
CV-G1518	REFINED CCNM DESIGN OPTION - GRADING AND DRAINAGE - OFFSITE CULVERT PROFILE - STA 18585+70
CV-G1519	REFINED CCNM DESIGN OPTION - GRADING AND DRAINAGE - OFFSITE CULVERT PROFILE - STA 18593+23
CV-G1520	REFINED CCNM DESIGN OPTION - GRADING AND DRAINAGE - OFFSITE CULVERT PROFILE - STA 18607+79
CV-G1521	REFINED CCNM DESIGN OPTION - GRADING AND DRAINAGE - OFFSITE CULVERT PROFILE - STA 18709+13

Projects\701206.00_CHSRBP_V00_CADD\CCNM_Option_D_Sheets\GE_NBP-GE-B0102 10:24:10 PM 1/21/2020 katharine.baker@tylin.com

REV	DATE	BY	CHK	APP	DESCRIPTION

DESIGNED BY K. BAKER
DRAWN BY R. GARCIA
CHECKED BY D. HOLMAN
IN CHARGE G. CAMPBELL
DATE 01/24/2020

**RECORD
PEPD
SUBMITTAL**

**NOT FOR
CONSTRUCTION**



CALIFORNIA HIGH-SPEED RAIL PROJECT
BAKERSFIELD TO PALMDALE
 REFINED CCNM DESIGN OPTION
 GENERAL
 INDEX OF DRAWING
 SHEET 1 OF 3

CONTRACT NO. HSR13-44
DRAWING NO. GE-B0102
SCALE NO SCALE
SHEET NO.

GRADING, DRAINAGE, AND RETAINING WALLS

DRAWING No.	DRAWING DESCRIPTION
CV-G1522	REFINED CCNM DESIGN OPTION - GRADING AND DRAINAGE - OFFSITE CULVERT PROFILE - STA 18730+54
CV-G1523	REFINED CCNM DESIGN OPTION - GRADING AND DRAINAGE - OFFSITE CULVERT PROFILE - STA 18737+12
CV-G1524	REFINED CCNM DESIGN OPTION - GRADING AND DRAINAGE - OFFSITE CULVERT PROFILE - STA 18739+99
CV-G1525	REFINED CCNM DESIGN OPTION - GRADING AND DRAINAGE - OFFSITE CULVERT PROFILE - STA 18760+28
CV-G1526	REFINED CCNM DESIGN OPTION - GRADING AND DRAINAGE - OFFSITE CULVERT PROFILE - STA 18774+46
CV-G1527	REFINED CCNM DESIGN OPTION - GRADING AND DRAINAGE - OFFSITE CULVERT PROFILE - STA 18789+78
CV-G1528	REFINED CCNM DESIGN OPTION - GRADING AND DRAINAGE - OFFSITE CULVERT PROFILE - STA 18818+12
CV-G1529	REFINED CCNM DESIGN OPTION - GRADING AND DRAINAGE - OFFSITE CULVERT PROFILE - STA 18890+42
CV-G1530	REFINED CCNM DESIGN OPTION - GRADING AND DRAINAGE - OFFSITE CULVERT PROFILE - STA 18890+42
CV-G1531	REFINED CCNM DESIGN OPTION - GRADING AND DRAINAGE - OFFSITE CULVERT PROFILE - STA 18901+81
CV-G1532	REFINED CCNM DESIGN OPTION - GRADING AND DRAINAGE - OFFSITE CULVERT PROFILE - STA 18912+98
CV-G1533	REFINED CCNM DESIGN OPTION - GRADING AND DRAINAGE - OFFSITE CULVERT PROFILE - STA 18925+73
CV-G1534	REFINED CCNM DESIGN OPTION - GRADING AND DRAINAGE - OFFSITE CULVERT PROFILE - STA 18925+73
CV-G1535	REFINED CCNM DESIGN OPTION - GRADING AND DRAINAGE - OFFSITE CULVERT PROFILE - STA 18933+45
CV-G1536	REFINED CCNM DESIGN OPTION - GRADING AND DRAINAGE - OFFSITE CULVERT PROFILE - STA 19030+40
CV-G1537	REFINED CCNM DESIGN OPTION - GRADING AND DRAINAGE - OFFSITE CULVERT PROFILE - STA 19070+72
CV-G4701	REFINED CCNM DESIGN OPTION - GRADING AND DRAINAGE - PLAN - STA 18295+00 to 18320+00
CV-G4702	REFINED CCNM DESIGN OPTION - GRADING AND DRAINAGE - PLAN - STA 18320+00 to 18345+00
CV-G4703	REFINED CCNM DESIGN OPTION - GRADING AND DRAINAGE - PLAN - STA 18345+00 to 18370+00
CV-G4704	REFINED CCNM DESIGN OPTION - GRADING AND DRAINAGE - PLAN - STA 18370+00 to 18395+00
CV-G4705	REFINED CCNM DESIGN OPTION - GRADING AND DRAINAGE - PLAN - STA 18395+00 to 18420+00
CV-G4706	REFINED CCNM DESIGN OPTION - GRADING AND DRAINAGE - PLAN - STA 18420+00 to 18445+00
CV-G4707	REFINED CCNM DESIGN OPTION - GRADING AND DRAINAGE - PLAN - STA 18445+00 to 18470+00
CV-G4708	REFINED CCNM DESIGN OPTION - GRADING AND DRAINAGE - PLAN - STA 18470+00 to 18495+00
CV-G4709	REFINED CCNM DESIGN OPTION - GRADING AND DRAINAGE - PLAN - STA 18495+00 to 18520+00
CV-G4710	REFINED CCNM DESIGN OPTION - GRADING AND DRAINAGE - PLAN - STA 18520+00 to 18545+00
CV-G4711	REFINED CCNM DESIGN OPTION - GRADING AND DRAINAGE - PLAN - STA 18545+00 to 18570+00
CV-G4712	REFINED CCNM DESIGN OPTION - GRADING AND DRAINAGE - PLAN - STA 18570+00 to 18595+00
CV-G4713	REFINED CCNM DESIGN OPTION - GRADING AND DRAINAGE - PLAN - STA 18595+00 to 18620+00
CV-G4714	REFINED CCNM DESIGN OPTION - GRADING AND DRAINAGE - PLAN - STA 18620+00 to 18645+00
CV-G4715	REFINED CCNM DESIGN OPTION - GRADING AND DRAINAGE - PLAN - STA 18645+00 to 18670+00
CV-G4716	REFINED CCNM DESIGN OPTION - GRADING AND DRAINAGE - PLAN - STA 18670+00 to 18695+00
CV-G4717	REFINED CCNM DESIGN OPTION - GRADING AND DRAINAGE - PLAN - STA 18695+00 to 18720+00
CV-G4718	REFINED CCNM DESIGN OPTION - GRADING AND DRAINAGE - PLAN - STA 18720+00 to 18745+00
CV-G4719	REFINED CCNM DESIGN OPTION - GRADING AND DRAINAGE - PLAN - STA 18745+00 to 18770+00
CV-G4720	REFINED CCNM DESIGN OPTION - GRADING AND DRAINAGE - PLAN - STA 18770+00 to 18795+00
CV-G4721	REFINED CCNM DESIGN OPTION - GRADING AND DRAINAGE - PLAN - STA 18795+00 to 18820+00
CV-G4722	REFINED CCNM DESIGN OPTION - GRADING AND DRAINAGE - PLAN - STA 18820+00 to 18845+00
CV-G4723	REFINED CCNM DESIGN OPTION - GRADING AND DRAINAGE - PLAN - STA 18845+00 to 18870+00
CV-G4724	REFINED CCNM DESIGN OPTION - GRADING AND DRAINAGE - PLAN - STA 18870+00 to 18895+00
CV-G4725	REFINED CCNM DESIGN OPTION - GRADING AND DRAINAGE - PLAN - STA 18895+00 to 18920+00
CV-G4726	REFINED CCNM DESIGN OPTION - GRADING AND DRAINAGE - PLAN - STA 18920+00 to 18945+00
CV-G4727	REFINED CCNM DESIGN OPTION - GRADING AND DRAINAGE - PLAN - STA 18945+00 to 18970+00
CV-G4728	REFINED CCNM DESIGN OPTION - GRADING AND DRAINAGE - PLAN - STA 18970+00 to 18995+00
CV-G4729	REFINED CCNM DESIGN OPTION - GRADING AND DRAINAGE - PLAN - STA 18995+00 to 19020+00
CV-G4730	REFINED CCNM DESIGN OPTION - GRADING AND DRAINAGE - PLAN - STA 19020+00 to 19045+00
CV-G4731	REFINED CCNM DESIGN OPTION - GRADING AND DRAINAGE - PLAN - STA 19045+00 to 19070+00
CV-G4732	REFINED CCNM DESIGN OPTION - GRADING AND DRAINAGE - PLAN - STA 19070+00 to 19095+00
CV-G4733	REFINED CCNM DESIGN OPTION - GRADING AND DRAINAGE - PLAN - STA 19095+00 to 19120+00
CV-G4734	REFINED CCNM DESIGN OPTION - GRADING AND DRAINAGE - PLAN - ACCESS ROAD "1845"
CV-G4735	REFINED CCNM DESIGN OPTION - GRADING AND DRAINAGE - PLAN - ACCESS ROAD "1850"
CV-G4736	REFINED CCNM DESIGN OPTION - GRADING AND DRAINAGE - PLAN - ACCESS ROAD "1850"
CV-G4737	REFINED CCNM DESIGN OPTION - GRADING AND DRAINAGE - PLAN - ACCESS ROAD "1860"

GRADING, DRAINAGE AND RETAINING WALLS

DRAWING No.	DRAWING DESCRIPTION
CV-G4738	REFINED CCNM DESIGN OPTION - GRADING AND DRAINAGE - PLAN - ACCESS ROAD "1860"
CV-G4739	REFINED CCNM DESIGN OPTION - GRADING AND DRAINAGE - PLAN - ACCESS ROAD "1860"
CV-G4740	REFINED CCNM DESIGN OPTION - GRADING AND DRAINAGE - PLAN - STA 18705+00 TO 18730+00
CV-G4741	REFINED CCNM DESIGN OPTION - GRADING AND DRAINAGE - PLAN - STA 18710+00 TO 18735+00
CV-G4742	REFINED CCNM DESIGN OPTION - GRADING AND DRAINAGE - PLAN - STA 18735+00 TO 18755+00
CV-G4743	REFINED CCNM DESIGN OPTION - GRADING AND DRAINAGE - PLAN - STA 18795+00 TO 18820+00
CV-G4744	REFINED CCNM DESIGN OPTION - GRADING AND DRAINAGE - PLAN - STA 18820+00 TO 18845+00
CV-G4745	REFINED CCNM DESIGN OPTION - GRADING AND DRAINAGE - PLAN - STA 18875+00 TO 18905+00
CV-G4746	REFINED CCNM DESIGN OPTION - GRADING AND DRAINAGE - PLAN - STA 18905+00 TO 18930+00
CV-G4747	REFINED CCNM DESIGN OPTION - GRADING AND DRAINAGE - PLAN - STA 18930+00 TO 18944+00
CV-G4748	REFINED CCNM DESIGN OPTION - GRADING AND DRAINAGE - PLAN - ACCESS ROAD "18920"
CV-G4749	REFINED CCNM DESIGN OPTION - GRADING AND DRAINAGE - PLAN - ACCESS ROAD "18920"
CV-G4750	REFINED CCNM DESIGN OPTION - GRADING AND DRAINAGE - PLAN - ACCESS ROAD "18920"
CV-G4751	REFINED CCNM DESIGN OPTION - GRADING AND DRAINAGE - PLAN - STA 19015+00 TO 19025+00
ST-G1201	REFINED CCNM DESIGN OPTION - RETAINING WALL - 18335 - PLAN AND PROFILE
ST-G1202	REFINED CCNM DESIGN OPTION - RETAINING WALL - 18430 - PLAN AND PROFILE
ST-G1203	REFINED CCNM DESIGN OPTION - RETAINING WALL - 18450 - PLAN AND PROFILE
ST-G1204	REFINED CCNM DESIGN OPTION - RETAINING WALL - 18603 - PLAN AND PROFILE
ST-G1205	REFINED CCNM DESIGN OPTION - RETAINING WALL - 18850 - PLAN AND PROFILE
ST-G1206	REFINED CCNM DESIGN OPTION - RETAINING WALL - 18884 - PLAN AND PROFILE
ST-G1207	REFINED CCNM DESIGN OPTION - RETAINING WALL - 19087 AND 19088 - PLAN AND PROFILE

TRACK AND ROADWAY STRUCTURES

DRAWING No.	DRAWING DESCRIPTION
ST-B0101	REFINED CCNM DESIGN OPTION - TRACK STRUCTURES - GENERAL NOTES AND LEGEND
ST-B0102	REFINED CCNM DESIGN OPTION - TRACK STRUCTURES - KEY MAP
ST-B3101	REFINED CCNM DESIGN OPTION - TRACK STRUCTURES - TYPICAL SECTIONS - SHEET 1 OF 6
ST-B3102	REFINED CCNM DESIGN OPTION - TRACK STRUCTURES - TYPICAL SECTIONS - SHEET 2 OF 6
ST-B3103	REFINED CCNM DESIGN OPTION - TRACK STRUCTURES - TYPICAL SECTIONS - SHEET 3 OF 6
ST-B3104	REFINED CCNM DESIGN OPTION - TRACK STRUCTURES - TYPICAL SECTIONS - SHEET 4 OF 6
ST-B3105	REFINED CCNM DESIGN OPTION - TRACK STRUCTURES - TYPICAL SECTIONS - SHEET 5 OF 6
ST-B3106	REFINED CCNM DESIGN OPTION - TRACK STRUCTURES - TYPICAL SECTIONS - SHEET 6 OF 6
ST-J1301	REFINED CCNM DESIGN OPTION - TRACK STRUCTURES - VIADUCT STATION 18465+50 to 18475+65 - PLAN AND ELEVATION
ST-J1302	REFINED CCNM DESIGN OPTION - TRACK STRUCTURES - VIADUCT STATION 18465+50 to 18475+65 - PLAN AND ELEVATION
ST-J1303	REFINED CCNM DESIGN OPTION - TRACK STRUCTURES - VIADUCT STATION 18491+62 to 18493+45 - PLAN AND ELEVATION
ST-J1304	REFINED CCNM DESIGN OPTION - TRACK STRUCTURES - VIADUCT STATION 18597+24 to 18603+56 - PLAN AND ELEVATION
ST-J1305	REFINED CCNM DESIGN OPTION - TRACK STRUCTURES - VIADUCT STATION 18744+33 to 18746+98 - PLAN AND ELEVATION
ST-J1306	REFINED CCNM DESIGN OPTION - TRACK STRUCTURES - VIADUCT STATION 18838+59 to 18884+25 - PLAN AND ELEVATION
ST-J1307	REFINED CCNM DESIGN OPTION - TRACK STRUCTURES - VIADUCT STATION 18838+59 to 18884+25 - PLAN AND ELEVATION
ST-J1308	REFINED CCNM DESIGN OPTION - TRACK STRUCTURES - VIADUCT STATION 18838+59 to 18884+25 - PLAN AND ELEVATION
ST-J1309	REFINED CCNM DESIGN OPTION - TRACK STRUCTURES - VIADUCT STATION 18838+59 to 18884+25 - PLAN AND ELEVATION
ST-J1310	REFINED CCNM DESIGN OPTION - TRACK STRUCTURES - VIADUCT STATION 18838+59 to 18884+25 - PLAN AND ELEVATION
ST-J1311	REFINED CCNM DESIGN OPTION - TRACK STRUCTURES - VIADUCT STATION 18838+59 to 18884+25 - PLAN AND ELEVATION
ST-J1312	REFINED CCNM DESIGN OPTION - TRACK STRUCTURES - SOUTH VIADUCT STATION 19097+53 to 19097+39.69 ALT 1,2,3,5 - PLAN AND ELEVATION
ST-J1313	REFINED CCNM DESIGN OPTION - TRACK STRUCTURES - NORTH VIADUCT STATION 19099+22 to 19097+68.69 ALT 1,2,3,5 - PLAN AND ELEVATION

Projects\701206.00_CHSRBP\00_CADD\CCNM_Option_D_Sheets\GE_NBP-GE-B0103

10:24:11 PM

katharine.baker@tylin.com 1/21/2020

REV	DATE	BY	CHK	APP	DESCRIPTION

DESIGNED BY
K. BAKER
DRAWN BY
R. GARCIA
CHECKED BY
D. HOLMAN
IN CHARGE
G. CAMPBELL
DATE
01/24/2020

**RECORD
PEPD
SUBMITTAL**

**NOT FOR
CONSTRUCTION**

TYLIN INTERNATIONAL

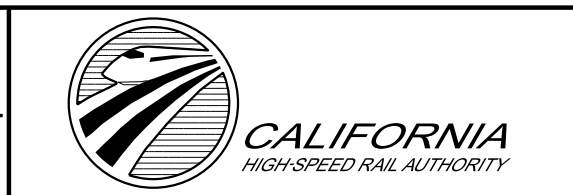

**CALIFORNIA HIGH-SPEED RAIL PROJECT
BAKERSFIELD TO PALMDALE**
REFINED CCNM DESIGN OPTION
GENERAL
INDEX OF DRAWING
SHEET 2 OF 3

CONTRACT NO.
HSR13-44
DRAWING NO.
GE-B0103
SCALE
NO SCALE
SHEET NO.

TRACTION POWER

DRAWING No.	DRAWING DESCRIPTION
TP-B0201	REFINED CCNM DESIGN OPTION - TRACTION POWER GENERAL - LEGEND
TP-B0202	REFINED CCNM DESIGN OPTION - TRACTION POWER GENERAL - KEY MAP
TP-B3201	REFINED CCNM DESIGN OPTION - TRACTION POWER GENERAL - TYPICAL SECTIONS - SHEET 1 OF 2
TP-B3202	REFINED CCNM DESIGN OPTION - TRACTION POWER GENERAL - TYPICAL SECTIONS - SHEET 2 OF 2
TP-D0201	REFINED CCNM DESIGN OPTION - TRACTION POWER FACILITY LAYOUT
TP-E4201	REFINED CCNM DESIGN OPTION - TYPICAL LAYOUT - TRACTION POWER SUBSTATION WITH 2 HIGH VOLTAGE TRANSFORMERS
TP-E4202	REFINED CCNM DESIGN OPTION - TYPICAL LAYOUT - PARALLELING STATION WITH 2 AUTOTRANSFORMERS
TP-O4401	REFINED CCNM DESIGN OPTION - TRACTION POWER SITE PLAN - PROPOSED PARALLELING STATION 3
TP-O4402	REFINED CCNM DESIGN OPTION - TRACTION POWER SITE PLAN - PROPOSED PARALLELING STATION 4
TP-O4403	REFINED CCNM DESIGN OPTION - TRACTION POWER SITE PLAN - PROPOSED TPSS #15

AUTOMATIC TRAIN CONTROL

DRAWING No.	DRAWING DESCRIPTION
TC-B0201	REFINED CCNM DESIGN OPTION - AUTOMATIC TRAIN CONTROL GENERAL - ABBREVIATIONS AND LEGEND
TC-B0202	REFINED CCNM DESIGN OPTION - AUTOMATIC TRAIN CONTROL GENERAL - KEY MAP
TC-B0203	REFINED CCNM DESIGN OPTION - AUTOMATIC TRAIN CONTROL LAYOUT
TC-F4201	REFINED CCNM DESIGN OPTION - AUTOMATIC TRAIN CONTROL SITE PLAN - SITE @ 18310+00
TC-F4202	REFINED CCNM DESIGN OPTION - AUTOMATIC TRAIN CONTROL SITE PLAN - SITE @ 18749+68

TUNNEL

DRAWING No.	DRAWING DESCRIPTION
TN-B0201	REFINED CCNM DESIGN OPTION - TUNNEL LEGEND
TN-B0202	REFINED CCNM DESIGN OPTION - KEY MAP - ALIGNMENT TUNNELS
TN-C1101	REFINED CCNM DESIGN OPTION - TUNNEL PROFILE - TUNNEL 4 - STA 18325+00 TO STA 18425+00
TN-C1102	REFINED CCNM DESIGN OPTION - TUNNEL PROFILE - TUNNEL 5 - STA 18520+00 TO STA 18570+00
TN-C1103	REFINED CCNM DESIGN OPTION - TUNNEL PROFILE - TUNNEL 6 - STA 18575+00 TO STA 18625+00
TN-C1104	REFINED CCNM DESIGN OPTION - TUNNEL PROFILE - TUNNEL 6 - STA 18625+00 TO STA 18675+00
TN-C1105	REFINED CCNM DESIGN OPTION - TUNNEL PROFILE - TUNNEL 6 - STA 18675+00 TO STA 18725+00
TN-C1106	REFINED CCNM DESIGN OPTION - TUNNEL PROFILE - TUNNEL 7 - STA 18925+00 TO STA 19025+00
TN-C4401	REFINED CCNM DESIGN OPTION - TUNNEL 4 - STA 18325+00 TO STA 18375+00
TN-C4402	REFINED CCNM DESIGN OPTION - TUNNEL 4 - STA 18375+00 TO STA 18425+00
TN-C4403	REFINED CCNM DESIGN OPTION - TUNNEL 4 - STA 18425+00 TO STA 18475+00
TN-C4404	REFINED CCNM DESIGN OPTION - TUNNEL 5 - STA 18475+00 TO STA 18525+00
TN-C4405	REFINED CCNM DESIGN OPTION - TUNNEL 5 - STA 18525+00 TO STA 18575+00
TN-C4406	REFINED CCNM DESIGN OPTION - TUNNEL 6 - STA 18575+00 TO STA 18625+00
TN-C4407	REFINED CCNM DESIGN OPTION - TUNNEL 6 - STA 18625+00 TO STA 18675+00
TN-C4408	REFINED CCNM DESIGN OPTION - TUNNEL 6 - STA 18675+00 TO STA 18725+00
TN-C4409	REFINED CCNM DESIGN OPTION - TUNNEL 7 - STA 18725+00 TO STA 18775+00
TN-C4410	REFINED CCNM DESIGN OPTION - TUNNEL 7 - STA 18775+00 TO STA 18825+00
TN-C4411	REFINED CCNM DESIGN OPTION - TUNNEL 7 - STA 18825+00 TO STA 18875+00
TN-C4412	REFINED CCNM DESIGN OPTION - TUNNEL 7 - STA 18875+00 TO STA 18925+00
TN-D3101	REFINED CCNM DESIGN OPTION - TUNNEL DRILL AND BLAST METHOD - SINGLE TUNNEL - CLEARANCE DIAGRAM
TN-D3102	REFINED CCNM DESIGN OPTION - TUNNEL DRILL AND BLAST METHOD - SINGLE TUNNEL - INITIAL SUPPORT
TN-D3103	REFINED CCNM DESIGN OPTION - TUNNEL CUT AND COVER BOX - CLEARANCE DIAGRAM - TANGENT TRACK
TN-D3104	REFINED CCNM DESIGN OPTION - TUNNEL CUT AND COVER BOX - CLEARANCE DIAGRAM - SUPER ELEVATED TRACK
TN-D3105	REFINED CCNM DESIGN OPTION - TWIN TUNNEL DRILL AND BLAST METHOD - CLEARANCE DIAGRAM - TANGENT TRACK
TN-D3106	REFINED CCNM DESIGN OPTION - TWIN TUNNEL DRILL AND BLAST METHOD - CLEARANCE DIAGRAM - SUPER ELEVATED TRACK
TN-D3107	REFINED CCNM DESIGN OPTION - TWIN TUNNEL DRILL AND BLAST METHOD - INITIAL SUPPORT
TN-D3108	REFINED CCNM DESIGN OPTION - TUNNEL TWIN TBM BORED TUNNELS - CLEARANCE DIAGRAM - TANGENT TRACK
TN-D3109	REFINED CCNM DESIGN OPTION - TUNNEL TWIN TBM BORED TUNNELS - CLEARANCE DIAGRAM - SUPER ELEVATED TRACK
TN-D3110	REFINED CCNM DESIGN OPTION - TUNNEL TWIN TBM BORED TUNNELS - INNITIAL SUPPORT

UTILITIES

DRAWING No.	DRAWING DESCRIPTION
UT-B0101	REFINED CCNM DESIGN OPTION - COMPOSITE UTILITY GENERAL - ABBREVIATIONS AND LEGEND
UT-B0102	REFINED CCNM DESIGN OPTION - COMPOSITE UTILITY GENERAL - GENERAL NOTES AND UTILITY OWNERS
UT-B0103	REFINED CCNM DESIGN OPTION - COMPOSITE UTILITY GENERAL - UTILITY CROSSING DETAIL
UT-B0104	REFINED CCNM DESIGN OPTION - COMPOSITE UTILITY GENERAL - KEY MAP
UT-C4701	REFINED CCNM DESIGN OPTION - COMPOSITE UTILITY PLAN - STA 18307+67 TO 18320+00 - PLAN
UT-C4702	REFINED CCNM DESIGN OPTION - COMPOSITE UTILITY PLAN - STA 18320+00 TO 18345+00 - PLAN
UT-C4703	REFINED CCNM DESIGN OPTION - COMPOSITE UTILITY PLAN - STA 18345+00 TO 18370+00 - PLAN
UT-C4704	REFINED CCNM DESIGN OPTION - COMPOSITE UTILITY PLAN - STA 18370+00 TO 18395+00 - PLAN
UT-C4705	REFINED CCNM DESIGN OPTION - COMPOSITE UTILITY PLAN - STA 18395+00 TO 18420+00 - PLAN
UT-C4706	REFINED CCNM DESIGN OPTION - COMPOSITE UTILITY PLAN - STA 18420+00 TO 18445+00 - PLAN
UT-C4707	REFINED CCNM DESIGN OPTION - COMPOSITE UTILITY PLAN - STA 18445+00 TO 18470+00 - PLAN
UT-C4708	REFINED CCNM DESIGN OPTION - COMPOSITE UTILITY PLAN - STA 18470+00 TO 18495+00 - PLAN
UT-C4709	REFINED CCNM DESIGN OPTION - COMPOSITE UTILITY PLAN - STA 18495+00 TO 18520+00 - PLAN
UT-C4710	REFINED CCNM DESIGN OPTION - COMPOSITE UTILITY PLAN - STA 18520+00 TO 18545+00 - PLAN
UT-C4711	REFINED CCNM DESIGN OPTION - COMPOSITE UTILITY PLAN - STA 18545+00 TO 18570+00 - PLAN
UT-C4712	REFINED CCNM DESIGN OPTION - COMPOSITE UTILITY PLAN - STA 18570+00 TO 18595+00 - PLAN
UT-C4713	REFINED CCNM DESIGN OPTION - COMPOSITE UTILITY PLAN - STA 18595+00 TO 18620+00 - PLAN
UT-C4714	REFINED CCNM DESIGN OPTION - COMPOSITE UTILITY PLAN - STA 18620+00 TO 18645+00 - PLAN
UT-C4715	REFINED CCNM DESIGN OPTION - COMPOSITE UTILITY PLAN - STA 18645+00 TO 18670+00 - PLAN
UT-C4716	REFINED CCNM DESIGN OPTION - COMPOSITE UTILITY PLAN - STA 18670+00 TO 18695+00 - PLAN
UT-C4717	REFINED CCNM DESIGN OPTION - COMPOSITE UTILITY PLAN - STA 18695+00 TO 18720+00 - PLAN
UT-C4718	REFINED CCNM DESIGN OPTION - COMPOSITE UTILITY PLAN - STA 18720+00 TO 18745+00 - PLAN
UT-C4719	REFINED CCNM DESIGN OPTION - COMPOSITE UTILITY PLAN - STA 18745+00 TO 18770+00 - PLAN
UT-C4720	REFINED CCNM DESIGN OPTION - COMPOSITE UTILITY PLAN - STA 18770+00 TO 18795+00 - PLAN
UT-C4721	REFINED CCNM DESIGN OPTION - COMPOSITE UTILITY PLAN - STA 18795+00 TO 18820+00 - PLAN
UT-C4722	REFINED CCNM DESIGN OPTION - COMPOSITE UTILITY PLAN - STA 18820+00 TO 18845+00 - PLAN
UT-C4723	REFINED CCNM DESIGN OPTION - COMPOSITE UTILITY PLAN - STA 18845+00 TO 18870+00 - PLAN
UT-C4724	REFINED CCNM DESIGN OPTION - COMPOSITE UTILITY PLAN - STA 18870+00 TO 18895+00 - PLAN
UT-C4725	REFINED CCNM DESIGN OPTION - COMPOSITE UTILITY PLAN - STA 18895+00 TO 18920+00 - PLAN
UT-C4726	REFINED CCNM DESIGN OPTION - COMPOSITE UTILITY PLAN - STA 18920+00 TO 18945+00 - PLAN
UT-C4727	REFINED CCNM DESIGN OPTION - COMPOSITE UTILITY PLAN - STA 18945+00 TO 18970+00 - PLAN
UT-C4728	REFINED CCNM DESIGN OPTION - COMPOSITE UTILITY PLAN - STA 18970+00 TO 18995+00 - PLAN
UT-C4729	REFINED CCNM DESIGN OPTION - COMPOSITE UTILITY PLAN - STA 18995+00 TO 19020+00 - PLAN
UT-C4730	REFINED CCNM DESIGN OPTION - COMPOSITE UTILITY PLAN - STA 19020+00 TO 19045+00 - PLAN
UT-C4731	REFINED CCNM DESIGN OPTION - COMPOSITE UTILITY PLAN - STA 19045+00 TO 19070+00 - PLAN
UT-C4732	REFINED CCNM DESIGN OPTION - COMPOSITE UTILITY PLAN - STA 19070+00 TO 19095+00 - PLAN
UT-C4733	REFINED CCNM DESIGN OPTION - COMPOSITE UTILITY PLAN - STA 19095+00 TO 19104+40 - PLAN

Projects\701206.00_CHSRBP\00_CADD\CCNM_Option_D_Sheets\GE_NBP-GE-B0104
 1/21/2020 10:24:20 PM
 katharine.baker@tylin.com

REV	DATE	BY	CHK	APP	DESCRIPTION

DESIGNED BY K. BAKER
DRAWN BY R. GARCIA
CHECKED BY D. HOLMAN
IN CHARGE G. CAMPBELL
DATE 01/24/2020

**RECORD
PEPD
SUBMITTAL**

**NOT FOR
CONSTRUCTION**



CALIFORNIA HIGH-SPEED RAIL PROJECT
BAKERSFIELD TO PALMDALE
 REFINED CCNM DESIGN OPTION
 GENERAL
 INDEX OF DRAWING
 SHEET 3 OF 3

CONTRACT NO. HSR13-44
DRAWING NO. GE-B0104
SCALE NO SCALE
SHEET NO.

A

AB AGGREGATE BASE
 ABBC ASBESTOS BONDED BITUMINOUS COATED
 ABM AIR-BLOWN MORTAR
 ABN ABANDON
 ABUT ABUTMENT
 AC ASPHALT CONCRETE
 ACB ASPHALT CONCRETE BASE
 ACP ASBESTOS CEMENT PIPE
 ADL ADDED DEAD LOAD
 ADJ ADJUST
 AFES ALTERNATIVE FLARED END SECTION
 AHD AHEAD
 ALT ALTERNATE
 AM TIME FROM MIDNIGHT TO NOON
 AP ALTERNATIVE PIPE
 APC ALTERNATIVE PIPE CULVERT
 APPROX APPROXIMATE
 APU ALTERNATIVE PIPE UNDERDRAIN
 ARS ACCELERATION RESPONSE SPECTRUM
 AR ACCESS RESTRICTION
 AS AGGREGATE SUBBASE
 ASRP ALUMINUM SPIRAL RIB PIPE
 ASSY ASSEMBLY
 ATC AUTOMATIC TRAIN CONTROL
 ATPB ASPHALT TREATED PERMEABLE BASE
 ATPM ASPHALT TREATED PERMEABLE MATERIAL
 AVE AVENUE
 AVG AVERAGE
 @ AT

B

BAGR BRIDGE APPROACH GUARD RAILING
 BB BEGINNING OF BRIDGE
 BC BEGIN HORIZONTAL CURVE
 BCC BALANCED CANTILEVER CONSTRUCTION
 BCR BEGIN CURB RETURN
 BEG BEGIN
 BIT CTD BITUMINOUS COATED
 BK BACK
 BKF BACKFILL
 BLDG BUILDING
 BLM BRIDGE-LOG MILE
 BLVD BOULEVARD
 BM BENCH MARK
 BND BOUND
 BNSF BURLINGTON NORTHERN & SANTA FE
 BOT BOTTOM
 BR BRIDGE
 BRG BEARING
 BTU BRITISH THERMAL UNIT
 BVC BEGIN VERTICAL CURVE
 BW BARBED WIRE

C

C CUT
 CAA CABLE ANCHOR ASSEMBLY
 CAP CORRUGATED ALUMINUM PIPE
 CAPA CORRUGATED ALUMINUM PIPE ARCH
 CAS CONSTRUCTION AREA SIGN
 CB CONCRETE BARRIER
 CBW CONCRETE BLOCK WALL
 CCNM CESAR CHAVEZ NATIONAL MONUMENT
 C-C CENTER TO CENTER
 CHSRA CALIFORNIA HIGH SPEED RAIL AUTHORITY
 CHST CALIFORNIA HIGH SPEED TRAIN
 CHSR CALIFORNIA HIGH SPEED RAIL
 CG CENTER OF GRAVITY
 CHNL CHANNEL
 CI CAST IRON
 CIDH CAST-IN-DRILLED-HOLE
 CIP CAST-IN-PLACE, CAST IRON PIPE
 CIPCP CAST IN PLACE CONCRETE PIPE
 CISS CAST-IN-STEEL-SHELL
 CJP COMPLETE JOINT PENETRATION
 CL CENTERLINE, CLASS
 CL2 CLASS 2
 CL-6 CHAIN LINK FENCE (6 FT)
 CLR CLEAR, CLEARANCE
 CM CORRUGATED METAL
 CMP CORRUGATED METAL PIPE
 CO COUNTY
 COL COLUMN
 CONC CONCRETE
 COND CONDUIT
 CONN CONNECTOR
 CONST CONSTRUCT, CONSTRUCTION
 CONT CONTINUOUS
 COORD COORDINATE
 CP CANDLEPOWER
 CR CREEK
 CRCP CONTINUOUS REINFORCED CONCRETE PAVEMENT
 CRSP CONCRETED ROCK SLOPE PROTECTION
 CS CURVE TO SPIRAL
 CSP CORRUGATED STEEL PIPE
 CSPA CORRUGATED STEEL PIPE ARCH
 CTB CEMENT TREATED BASE
 CTPB CEMENT TREATED PERMEABLE BASE
 CTPM CEMENT TREATED PERMEABLE MATERIAL
 CTRS CENTERS
 CVFPB CENTRAL VALLEY FLOOD PROTECTION BOARD
 CULV CULVERT
 C CENTERLINE

D

D DEPTH
 D & B DRILL AND BLAST
 DD DOWNDRAIN, DIRECTIVE DRILLING
 DBL DOUBLE
 DEG DEGREE
 DEL DELINEATOR
 DET DETAIL, DETOUR
 DF DOUGLAS FIR
 DI DRAINAGE INLET, DROP INLET
 DIA DIAMETER
 DIAPH DIAPHRAGM
 DIST DISTANCE, DISTRICT
 DMBB DOUBLE METAL BEAM BARRIER
 DR DRIVE
 DS DESIGN SPEED
 DTBB DOUBLE THRIE BEAM BARRIER
 DWG DRAWING
 DWP DEPARTMENT OF WATER AND POWER
 DWY DRIVEWAY

E

E EAST, EASTING, ELECTRICAL
 EA ACTUAL SUPERELEVATION
 EU UNBALANCED SUPERELEVATION
 EASE EASEMENT
 EB END OF BRIDGE, EASTBOUND
 EC END HORIZONTAL CURVE
 ECR END CURB RETURN
 ED EDGE DRAIN
 EDC EDGE DRAIN CLEANOUT
 EDO EDGE DRAIN OUTLET
 EDV EDGE DRAIN VENT
 ELEC ELECTROLIER
 ELECT ELECTRIC
 ELEV ELEVATION
 EMB EMBANKMENT
 ENGR ENGINEER
 EOD EDGE OF DECK
 EP EDGE OF PAVEMENT
 EQ EQUATION, EQUAL
 ES EDGE OF SHOULDER
 ETW EDGE OF TRAVELED WAY
 EVC END VERTICAL CURVE
 EW ENDWALL
 EXC EXCAVATION
 EXIST, EX. EXISTING
 EXP EXPANSION
 EXP JT EXPANSION JOINT
 EXWY EXPRESSWAY
 EXT EXTERIOR

F

F FILL, FIXED BEARING
 F & C FRAME AND COVER
 F & G FRAME AND GRATE
 FB FLOOR BEAM
 F-B FRESNO TO BAKERSFIELD
 FDN FOUNDATION
 FEBT FACING EASTBOUND TRAFFIC
 FES FLARED END SECTION
 FF FILTER FABRIC
 FG FINISHED GRADE
 FH FIRE HYDRANT
 FIG FIGURE
 FL FLOW LINE
 FLS FIRE AND LIFE SAFETY
 FNBT FACING NORTHBOUND TRAFFIC
 FOC FACE OF CONCRETE
 FR RD FRONTAGE ROAD
 FS FAR SIDE, FINISHED SURFACE
 FSBT FACING SOUTHBOUND TRAFFIC
 FT FOOT, FEET
 FTG FOOTING
 FWBT FACING WESTBOUND TRAFFIC
 FWY FREEWAY
 FPLM FULL SPAN PRECAST LAUNCHING METHOD

G

G ACCELERATION DUE TO GRAVITY, NATURAL GAS
 GA GAUGE
 GALV GALVANIZED
 GP GRADING PLANE
 GR GUARD RAILING
 GSP GALVANIZED STEEL PIPE
 GTR GUTTER

H

H HEIGHT
 HR HOUR
 HD HORIZONTAL DRAIN
 HDC HIGH DESERT CORRIDOR
 HDWL HEADWALL
 HEX HD HEXAGONAL HEAD
 HMA HOT MIXED ASPHALT
 HOR HORIZONTAL
 HP HINGE POINT, HORSEPOWER
 HPS HIGH PERFORMANCE STEEL
 HS HIGH STRENGTH
 HST HIGH SPEED TRAIN
 HSR HIGH SPEED RAIL
 HV HIGH VOLTAGE
 HW HEADWALL, HIGH WATER
 HWM HIGH WATER MARK
 HWY HIGHWAY

Projects\701206\00_CHSRBP\00_CADD\CCNM_Option_D\Sheets\GE\BP-GE-B0105
 10:24:12 PM 1/21/2020
 katharine.baker@tylin.com

REV	DATE	BY	CHK	APP	DESCRIPTION

DESIGNED BY
K. BAKER
 DRAWN BY
R. GARCIA
 CHECKED BY
D. HOLMAN
 IN CHARGE
G. CAMPBELL
 DATE
01/24/2020

**RECORD
PEPD
SUBMITTAL**

**NOT FOR
CONSTRUCTION**

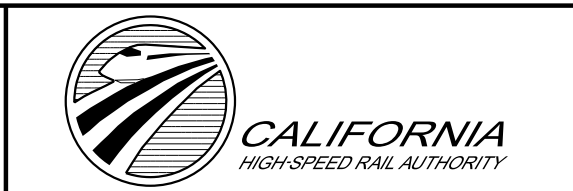

CALIFORNIA HIGH-SPEED RAIL PROJECT
BAKERSFIELD TO PALMDALE
 REFINED CCNM DESIGN OPTION
 GENERAL
 ABBREVIATIONS
 SHEET 1 OF 3

CONTRACT NO.
HSR13-44
 DRAWING NO.
GE-B0105
 SCALE
NO SCALE
 SHEET NO.

Projects\701206.00_CHSRBP\00_CADD\CCNM_Option D\Sheets\GE\BP-GE-B0106
 10:24:13 PM
 1/21/2020
 katharine.baker@tylin.com

I

IB IMPORTED BORROW
 ID INSIDE DIAMETER
 IF INSIDE FACE
 IN INCH, INCHES
 INT INTERIOR
 INV INVERT
 IRR IRRIGATION

J

JCT JUNCTION
 JP JOINT POLE
 JPCP JOINTED PLAIN CONCRETE PAVEMENT
 JS JUNCTION STRUCTURE
 JT JOINT

K

K DISTANCE TO ACHIEVE 1% GRADE CHANGE

L

L LENGTH
 LAT LATITUDE
 LCB LEAN CONCRETE BASE
 LGA LOCALLY GENERATED ALTERNATIVE
 LID BMP LOW IMPACT DEVELOPMENT BEST MANAGEMENT PRACTICES
 LMF LIGHT MAINTENANCE FACILITY
 LN LANE
 LOC LOCATION
 LOL LAYOUT LINE
 LONG LONGITUDE
 LONGIT LONGITUDINAL
 LS LENGTH OF SPIRAL
 LC LENGTH OF CURVE
 LT LEFT
 LV LOW VOLTAGE

M

MAINT MAINTENANCE
 MAX MAXIMUM
 MB METAL BEAM
 MBB METAL BEAM BARRIER
 MBGR METAL BEAM GUARD RAILING
 MED MEDIAN
 MH MANHOLE
 MIN MINIMUM
 MISC MISCELLANEOUS
 MISC I & S MISCELLANEOUS IRON AND STEEL
 MKR MARKER
 M/L MAIN LINE (RAILWAY)
 MOD MODIFIED, MODIFY
 MON MONUMENT
 MOIF MAINTENANCE OF INFRASTRUCTURE FACILITY
 MOIS MAINTENANCE OF INFRASTRUCTURE SIDING

M CONTINUED

MP METAL PLATE
 MPGR METAL PLATE GUARD RAILING
 MPH MILES PER HOUR
 MR MOVEMENT RATING
 MSE MECHANICALLY STABILIZED EARTH
 MTL MATERIAL
 MSS MOVING SCAFFOLDING SYSTEM

N

N NORTH, NORTHING
 NB NORTHBOUND
 NO. NUMBER (MUST HAVE PERIOD)
 NOS. NUMBERS (MUST HAVE PERIOD)
 NPS NOMINAL PIPE SIZE
 NS NEAR SIDE
 NTS NOT TO SCALE
 N/A NOT APPLICABLE

O

OBLR OBLITERATE
 OC OVERCROSSING
 OCS OVERHEAD CONTACT SYSTEM
 OD OUTSIDE DIAMETER
 OF OUTSIDE FACE
 OG ORIGINAL GROUND
 OGAC OPEN GRADED ASPHALT CONCRETE
 OH OVERHEAD
 O-O OUT TO OUT
 OPP OPPOSITE
 OSD ONSITE STORMWATER DETENTION

P

P PAGE
 PAP PERFORATED ALUMINUM PIPE
 PB PULL BOX, PALMDALE TO BURBANK
 PC POINT OF CURVATURE, PRECAST
 PCC POINT OF COMPOUND CURVE, PORTLAND CEMENT CONCRETE
 PCP PERFORATED CONCRETE PIPE, PRESTRESSED CONCRETE PIPE
 PCVC POINT OF COMPOUND VERTICAL CURVE
 PED PEDESTRIAN
 PED OC PEDESTRIAN OVERCROSSING
 PED UC PEDESTRIAN UNDERCROSSING
 PERM MTL PERMEABLE MATERIAL
 PG PROFILE GRADE
 PG&E PACIFIC GAS AND ELECTRIC
 PI POINT OF INTERSECTION
 PJP PARTIAL JOINT PENETRATION
 PL PLATE
 P/L PROPERTY LINE
 PM POST MILE, TIME FROM NOON TO MIDNIGHT
 PN PAVING NOTCH

P CONTINUED

POB POINT OF BEGINNING
 POC POINT OF HORIZONTAL CURVE
 POE POINT OF ENDING
 POT POINT OF TANGENT
 POVC POINT OF VERTICAL CURVE
 PP PIPE PILE, PLASTIC PIPE, POWER POLE
 PPEF PROPOSED PERMANENT ENVIRONMENTAL FOOTPRINT
 PPL PREFORMED PERMEABLE LINER
 PPP PERFORATED PLASTIC PIPE
 PRC POINT OF REVERSE CURVE
 PRF PAVEMENT REINFORCING FABRIC
 PROP PROPOSED
 PRVC POINT OF REVERSE VERTICAL CURVE
 PS&E PLANS, SPECIFICATIONS AND ESTIMATES
 PS, P/S PRESTRESSED, PARALLELING STATION
 PSP PERFORATED STEEL PIPE
 PT POINT OF TANGENCY
 PTEF PROPOSED TEMPORARY ENVIRONMENTAL FOOTPRINT
 PTSW POINT OF TRACK SWITCH
 PVC POLYVINYL CHLORIDE
 PVI POINT OF VERTICAL INTERSECTION
 PVMT PAVEMENT
 PVP MAINTENANCE VEHICLE PULLOUT

Q

QTY QUANTITY

R

R RADIUS, ROLLER BEARING
 R & D REMOVE AND DISPOSE
 R & S REMOVE AND SALVAGE
 R/C RATE OF CHANGE
 RCA REINFORCED CONCRETE ARCH
 RCB REINFORCED CONCRETE BOX
 RCP REINFORCED CONCRETE PIPE
 RCPA REINFORCED CONCRETE PIPE ARCH
 RD ROAD
 RDWY ROADWAY
 REALIGN REALIGNMENT
 REINF REINFORCED, REINFORCEMENT, REINFORCING
 REL RELOCATE
 REPL REPLACEMENT
 RET RETAINING
 REV REVISED
 RFND REFINED
 RM ROAD-MIXED
 RP RADIUS POINT, REFERENCE POINT
 RR RAILROAD
 RSP ROCK SLOPE PROTECTION
 RT RIGHT
 RTE ROUTE
 RW REDWOOD, RETAINING WALL

R CONTINUED

R/W RIGHT OF WAY
 RWY RAILWAY

S

S SOUTH, SUPPLEMENT, SLOPE, STATION LINE, SEWER
 SAE STRUCTURE APPROACH EMBANKMENT
 SALV SALVAGE
 SAPP STRUCTURAL ALUMINUM PLATE PIPE
 SB SOUTHBOUND
 SC SPIRAL TO CURVE
 SCE SOUTHERN CALIFORNIA EDISON
 SCSP SLOTTED CORRUGATED STEEL PIPE
 SD STORM DRAIN
 SEC SECOND
 SECT SECTION
 SEP SEPARATION
 SG SUBGRADE
 SHLD SHOULDER
 SHT SHEET
 SIM SIMILAR
 SM SELECTED MATERIAL
 SPEC SPECIAL, SPECIFICATIONS
 SPP SLOTTED PLASTIC PIPE
 SS SLOPE STAKE, SPIRAL TO SPIRAL, SUBSTATION
 SSBM STRAP AND SADDLE BRACKET METHOD
 SSD STRUCTURAL SECTION DRAIN
 SSPA STRUCTURAL STEEL PLATE ARCH
 SSPP STRUCTURAL STEEL PLATE PIPE
 SSPPA STRUCTURAL STEEL PLATE PIPE ARCH
 SSRP STEEL SPIRAL RIB PIPE
 SR STATE ROUTE
 ST STREET, SPIRAL TO TANGENT
 STA STATION
 STBB SINGLE THRIE BEAM BARRIER
 STD STANDARD
 STR STRUCTURE
 SRS STANDALONE RADIO SITE
 SURF SURFACING
 SW SIDEWALK, SOUND WALL
 SWR SEWER
 SWS SWITCHING STATION
 SYM SYMMETRICAL
 S4S SURFACE 4 SIDES
 SJVR SAN JOAQUIN VALLEY RAILROAD

REV	DATE	BY	CHK	APP	DESCRIPTION

DESIGNED BY
K. BAKER
 DRAWN BY
R. GARCIA
 CHECKED BY
D. HOLMAN
 IN CHARGE
G. CAMPBELL
 DATE
01/24/2020

**RECORD
PEPD
SUBMITTAL**

**NOT FOR
CONSTRUCTION**



CALIFORNIA HIGH-SPEED RAIL PROJECT
BAKERSFIELD TO PALMDALE
 REFINED CCNM DESIGN OPTION
 GENERAL
 ABBREVIATIONS
 SHEET 2 OF 3

CONTRACT NO.
HSR13-44
 DRAWING NO.
GE-B0106
 SCALE
NO SCALE
 SHEET NO.

T

T TANGENT, SEMI-TANGENT
 TAB TABLET
 TAN TANGENT
 TBB THRIE BEAM BARRIER
 TBR TIMBER
 TC TOP OF CURB, TANGENT TO CURVE
 TCB TRAFFIC CONTROL BOX
 TEL TELEPHONE
 TEMP TEMPORARY
 TF TOP OF FOOTING
 TG TOP OF GRADE
 TM TECHNICAL MEMORANDUM
 TOT TOTAL
 TP TRACTION POWER, TUNNEL PORTAL
 TPF TRACTION POWER FACILITY
 TPB TREATED PERMEABLE BASE
 TPM TREATED PERMEABLE MATERIAL
 TPS TRACTION POWER SUPPLY SYSTEM
 TPSS TRACTION POWER SUBSTATION
 TRANS TRANSITION, TRANSVERSE
 TS TRAFFIC SIGNAL, TUBULAR STEEL,
 TANGENT TO SPIRAL
 TOR TOP OF RAIL
 TW TOP OF WALL
 TYP TYPICAL

U

UC UNDERCROSSING
 UD UNDERDRAIN
 UON UNLESS OTHERWISE NOTED
 UP UNDERPASS
 UPRR UNION PACIFIC RAILROAD
 USFWS UNITED STATES FISH AND WILDLIFE
 SERVICE

V

V VALVE, DESIGN SPEED
 VAR VARIABLE
 VC VERTICAL CURVE
 VCP VITRIFIED CLAY PIPE
 VERT VERTICAL
 VIA VIADUCT
 VOL VOLUME

W

W WEST, WIDTH, WATER
 WB WESTBOUND
 WH WEEP HOLE
 WM WIRE MESH
 WS WATER SURFACE
 WSP WELDED STEEL PIPE
 WT WEIGHT
 WV WATER VALVE
 WW WINGWALL
 WWL WINGWALL LAYOUT LINE
 W/ WITH

X

X SEC CROSS SECTION
 XING CROSSING

Y

YR YEAR
 YRS YEARS

Z

REV	DATE	BY	CHK	APP	DESCRIPTION

DESIGNED BY
K. BAKER
 DRAWN BY
R. GARCIA
 CHECKED BY
D. HOLMAN
 IN CHARGE
G. CAMPBELL
 DATE
01/24/2020

**RECORD
 PEPD
 SUBMITTAL**

**NOT FOR
 CONSTRUCTION**











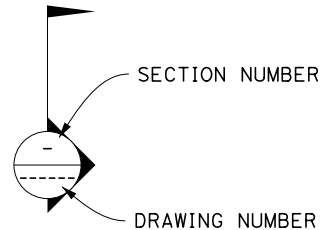



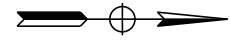

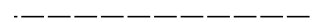







**CALIFORNIA HIGH-SPEED RAIL PROJECT
 BAKERSFIELD TO PALMDALE**
 REFINED CCNM DESIGN OPTION
 GENERAL
 ABBREVIATIONS
 SHEET 3 OF 3



CONTRACT NO. HSR13-44
DRAWING NO. GE-B0107
SCALE NO SCALE
SHEET NO.

LEGEND:

PLAN

-  SECTION NUMBER
DRAWING NUMBER
-  CURVE DATA (ALIGNMENTS, ROADWAYS)
-  CURVE DATA (STRUCTURES)
-  LINE DATA (ALIGNMENTS, ROADWAYS)
-  NORTH ARROW
-  EXIST RIGHT OF WAY
-  LIMITS OF EXCAVATION (CUT)
-  LIMITS OF EMBANKMENT (FILL)
-  FAULT ZONE
-  EXIST CALTRANS RIGHT OF WAY
-  EXIST RETAINING WALL
-  PPEF
-  PROPOSED COLUMN/FOOTING
-  PROPOSED FENCE
-  PROPOSED RETAINING WALL
-  PROPOSED CONCRETE BARRIER
-  PROPOSED RIGHT OF WAY
-  PROPOSED TUNNEL
-  PTEF
-  SRS
STANDALONE RADIO SITE
-  AUTOMATIC TRAIN CONTROL SYSTEM SITE A
-  AUTOMATIC TRAIN CONTROL SYSTEM SITE B
-  AUTOMATIC TRAIN CONTROL SYSTEM SITE D

PLAN

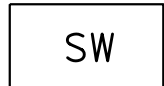
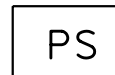
-  AUTOMATIC TRAIN CONTROL SYSTEM SITE E
-  TRACK CROSSING PANEL
-  SUBSTATION
-  SWITCHING STATION
-  PARALLELING STATION

PROFILE

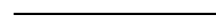
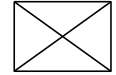
-  ORIGINAL GROUND
-  PROPOSED CHSR ELEVATION
-  STRUCTURAL CLEARANCE ENVELOPE

GENERAL NOTES

1. ROADWAY IMPROVEMENTS SHOWN ON ROADWAY PLANS.
2. TRACK ALIGNMENT CONTROL LINE IS THE CENTERLINE OF THE SB TRACK.
3. TRACK PROFILE SHOWN IS THE TOP OF THE LOW (NON-SUPERELEVATED) RAIL OF THE SB TRACK.
4. ALL DIMENSIONS ARE IN FEET UNLESS OTHERWISE NOTED.
5. ROW LIMITS SHOWN ARE LIMITS OF PROPERTY TO BE OWNED BY CHSR AUTHORITY.
6. PPEF SHOWN IS LIMIT OF PERMANENT GROUND DISTURBANCE ASSOCIATED WITH THE PROJECT.
7. PTEF SHOWN IS LIMIT OF TEMPORARY GROUND DISTURBANCE ASSOCIATED WITH THE PROJECT.
8. ALL UTILITIES ARE TO BE FIELD VERIFIED PRIOR TO CONSTRUCTION.
9. FOR DETAILED STRUCTURE DEPTH INFORMATION SEE STRUCTURAL PLAN SET.

Projects\701206_00_CHSRBP\00_CADD\CCNM Option D\Sheets\TT\BP-TT-B0201.dgn

9:57:43 PM

1/22/2020

andrew.carson@tylin.com

REV	DATE	BY	CHK	APP	DESCRIPTION

DESIGNED BY
A. CARSON
DRAWN BY
A. CARSON
CHECKED BY
S. LANDOLT
IN CHARGE
G. CAMPBELL
DATE
01/24/2020

**RECORD
PEPD
SUBMITTAL**

**NOT FOR
CONSTRUCTION**

TYLIN INTERNATIONAL



**CALIFORNIA HIGH-SPEED RAIL PROJECT
BAKERSFIELD TO PALMDALE**
REFINED CCNM DESIGN OPTION
TRACK GENERAL
SYMBOLS, LEGEND, AND GENERAL NOTES

CONTRACT NO.
HSR13-44
DRAWING NO.
TT-B0201
SCALE
NO SCALE
SHEET NO.

NOTES:

1. RADII ARE POSITIVE IN VALUE BY THE CONVENTION OF LOOKING UP STATION AND TURNING RIGHT.

REFINED CCNM STA 18307+67.15=
ALT 1,2,3,5 STA 18307+67.15

REFINED CCNM DESIGN OPTION SB													
TRACK GEOMETRY DATA													
CURVE No.	DESCRIPTION	BEARING	DISTANCE (ft)	STATION	NORTHING	EASTING	R (ft)	Lc (ft)	SPIRAL TYPE	Ls (ft)	Eq (IN)	Eu (IN)	V (MPH)
6	POT			18307+67.15	2283684.03	6373105.94							250
	TS	S74°57'09"E	175.15	18309+42.30	2283638.56	6373275.09			Cosine				250
	SC			18331+92.30	2283030.26	6375441.14				2250			250
	CS			18380+83.20	2281210.67	6379975.14	30000	4890.90	Cosine		5.50	2.83	250
	ST			18403+33.20	2280152.80	6381960.77				2250			250
7	TS	S61°18'51"E	1152.83	18414+86.03	2279599.44	6382972.11			Cosine				220
	SC			18431+86.03	2278800.63	6384472.61				1700			220
	CS			18445+42.24	2278233.68	6385704.40	-22050	1356.21	Cosine		5.80	2.98	220
	ST			18462+42.24	2277613.40	6387287.08				1700			220
	TS	S69°15'20"E	4132.92	18503+75.16	2276149.53	6391152.06			Cosine				220
8	SC			18520+75.16	2275529.21	6392734.71				1700			220
	CS			18667+88.24	2265844.79	6403446.27	22000	14713.08	Cosine		5.80	3.00	220
	ST			18684+88.24	2264332.46	6404222.45				1700			220
	TS	S26°30'37"E	1046.67	18695+34.91	2263395.84	6404689.64			Cosine				220
	SC			18712+34.91	2261883.49	6405465.79				1700			220
9	CS			18818+71.98	2254121.67	6412587.87	-22050	10637.07	Cosine		5.80	2.98	220
	ST			18835+71.98	2253218.62	6414028.04				1700			220
	TS	S58°34'03"E	5382.63	18889+54.61	2250411.61	6418620.80			Cosine				250
	SC			18904+04.61	2249649.53	6419854.37				1450			250
	CS			18933+14.12	2248014.09	6422260.13	45000	2909.51	Cosine		3.00	2.56	250
10	ST			18947+64.12	2247147.37	6423422.55				1450			250
	TS	S53°01'00"E	1545.88	18963+10.00	2246217.40	6424657.42			Cosine				250
	SC			18988+10.00	2244689.72	6426636.12				2500			250
	CS			19055+04.79	2239925.54	6431321.08	31000	6694.78	Cosine		5.50	2.56	250
	ST			19080+04.79	2237921.50	6432815.36				2500			250
11	POT	S36°01'21"E	2435.23	19104+40.02	2235951.92	6434247.52			Cosine				250

REFINED CCNM STA 19104+40.02=
ALT 1,2,3,5 STA 19094+56.71

REFINED CCNM STA 18307+65.52=
ALT 1,2,3,5 STA 18307+65.52

REFINED CCNM DESIGN OPTION NB													
TRACK GEOMETRY DATA													
CURVE No.	DESCRIPTION	BEARING	DISTANCE (ft)	STATION	NORTHING	EASTING	R (ft)	Lc (ft)	SPIRAL TYPE	Ls (ft)	Eq (IN)	Eu (IN)	V (MPH)
6N	POT			18307+65.52	2283708.41	6373112.50							250
	TS	S74°57'09"E	175.15	18309+40.67	2283662.94	6373281.64			Cosine				250
	SC			18331+90.67	2283054.66	6375447.71				2250			250
	CS			18380+87.58	2281232.84	6379987.26	30025.25	4896.91	Cosine		5.50	2.83	250
	ST			18403+37.58	2280174.95	6381972.89				2250			250
7N	TS	S61°18'51"E	1152.83	18414+90.41	2279621.59	6382984.23			Cosine				220
	SC			18431+90.41	2278822.80	6384484.74				1700			220
	CS			18445+43.12	2278257.31	6385713.36	-22024.75	1352.71	Cosine		5.80	2.98	220
	ST			18462+43.12	2277637.02	6387296.02				1700			220
	TS	S69°15'20"E	4132.92	18503+76.04	2276173.14	6391161.00			Cosine				220
8N	SC			18520+76.04	2275552.85	6392743.67				1700			220
	CS			18668+07.96	2265856.07	6403468.89	22025.25	14731.92	Cosine		5.80	3.00	220
	ST			18685+07.96	2264343.73	6404245.05				1700			220
	TS	S26°30'37"E	1046.67	18695+54.63	2263407.11	6404712.24			Cosine				220
	SC			18712+54.63	2261894.77	6405488.40				1700			220
9N	CS			18818+77.57	2254143.23	6412601.05	-22024.75	10622.94	Cosine		5.80	2.98	220
	ST			18835+77.57	2253240.16	6414041.21				1700			220
	TS	S58°34'03"E	5826.95	18894+04.52	2250201.44	6419013.09			Cosine				250
	SC			18908+04.52	2249465.85	6420204.24				1400			250
	CS			18937+70.43	2247798.72	6422656.61	45066	2965.91	Cosine		3.00	2.56	250
10N	ST			18951+70.43	2246961.69	6423778.82				1400			250
	TS	S53°01'00"E	1149.59	18963+20.02	2246270.12	6424697.12			Cosine				250
	SC			18988+20.02	2244742.49	6426675.87				2500			250
	CS			19055+34.38	2239964.40	6431374.51	31066	6714.36	Cosine		5.50	2.56	250
	ST			19080+34.38	2237960.32	6432868.74				2500			250
11N	POT	S36°01'21"E	2435.23	19104+69.61	2235990.73	6434300.90			Cosine				250

REFINED CCNM STA 19104+69.61=
ALT 1,2,3,5 STA 19094+86.31

Projects\701206_00_CHSRBP\00_CADD\CCNM Option D\Sheets\TT\BP-TT-B0202.dgn

9:57:53 PM

1/22/2020

andrew.carson@tylin.com

REV	DATE	BY	CHK	APP	DESCRIPTION

DESIGNED BY
A. CARSON
DRAWN BY
A. CARSON
CHECKED BY
S. LANDOLT
IN CHARGE
G. CAMPBELL
DATE
01/24/2020

**RECORD
PEPD
SUBMITTAL**

**NOT FOR
CONSTRUCTION**



CALIFORNIA HIGH-SPEED RAIL PROJECT
BAKERSFIELD TO PALMDALE
REFINED CCNM DESIGN OPTION
TRACK GENERAL
HORIZONTAL ALIGNMENT DATA TABLE

CONTRACT NO.
HSR13-44
DRAWING NO.
TT-B0202
SCALE
NO SCALE
SHEET NO.

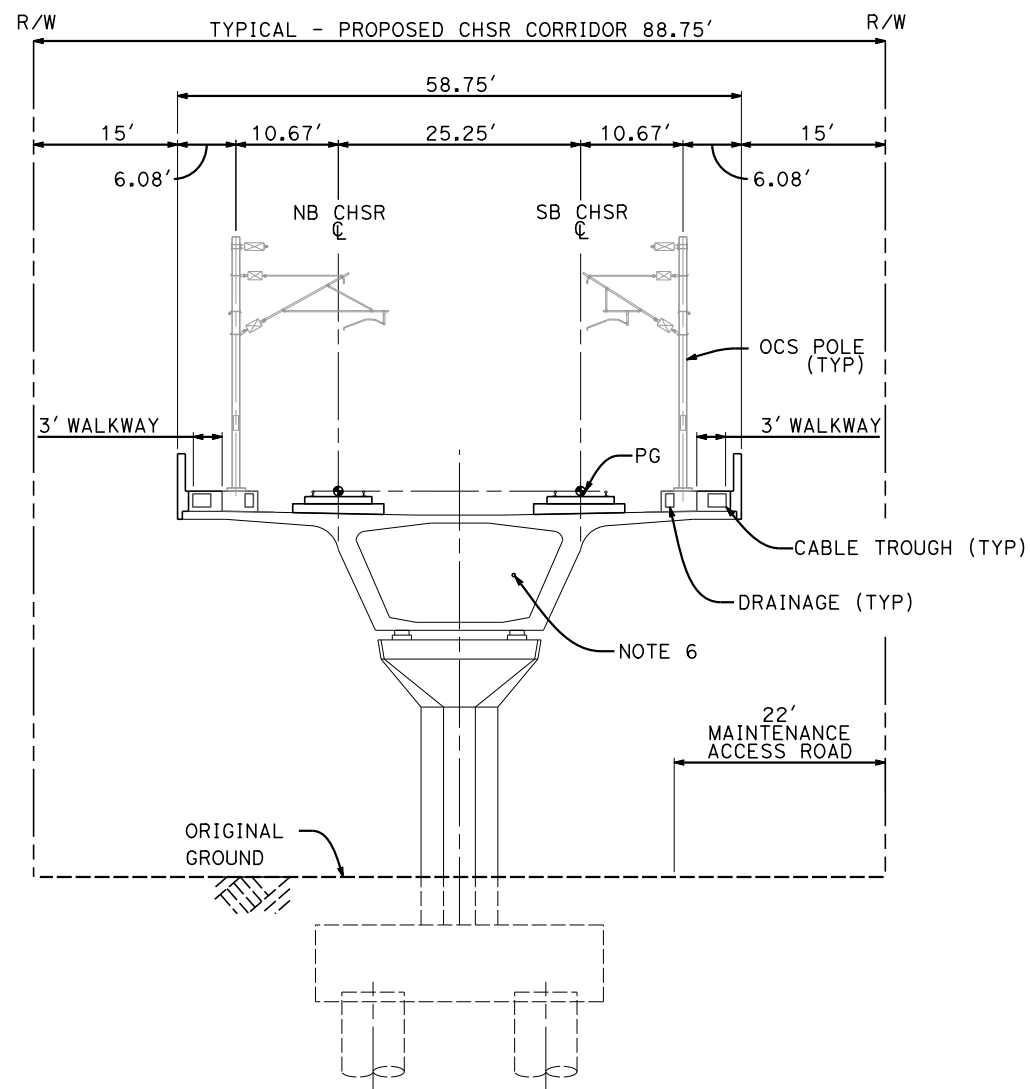

SECTION C

- STA 18465+50 TO 18475+65 (REFINED CCNM)
- STA 18491+62 TO 18493+45 (REFINED CCNM)
- STA 18597+24 TO 18603+56 (REFINED CCNM)
- STA 18744+33 TO 18746+98 (REFINED CCNM)
- STA 18838+59 TO 18850+78 (REFINED CCNM)
- STA 18853+14 TO 18884+25 (REFINED CCNM)

NOTES:

1. TRACKFORM SHOWN IS INDICATIVE
2. SUPERELEVATION IS NOT SHOWN. THE AMOUNT OF APPLIED SUPERELEVATION IS SHOWN IN THE CURVE TABLES ON SHEET TT-B0202
3. FOR STRUCTURAL DIMENSIONS SEE ST TYPICAL SECTIONS
4. FOR TUNNEL DETAILS SEE TN TYPICAL SECTIONS
5. FOR TRACTION POWER FACILITY DETAILS SEE TP TYPICAL SECTIONS
6. PROPOSED 4" CHSR WATERLINE FROM STATION 18034+00 TO 19591+00

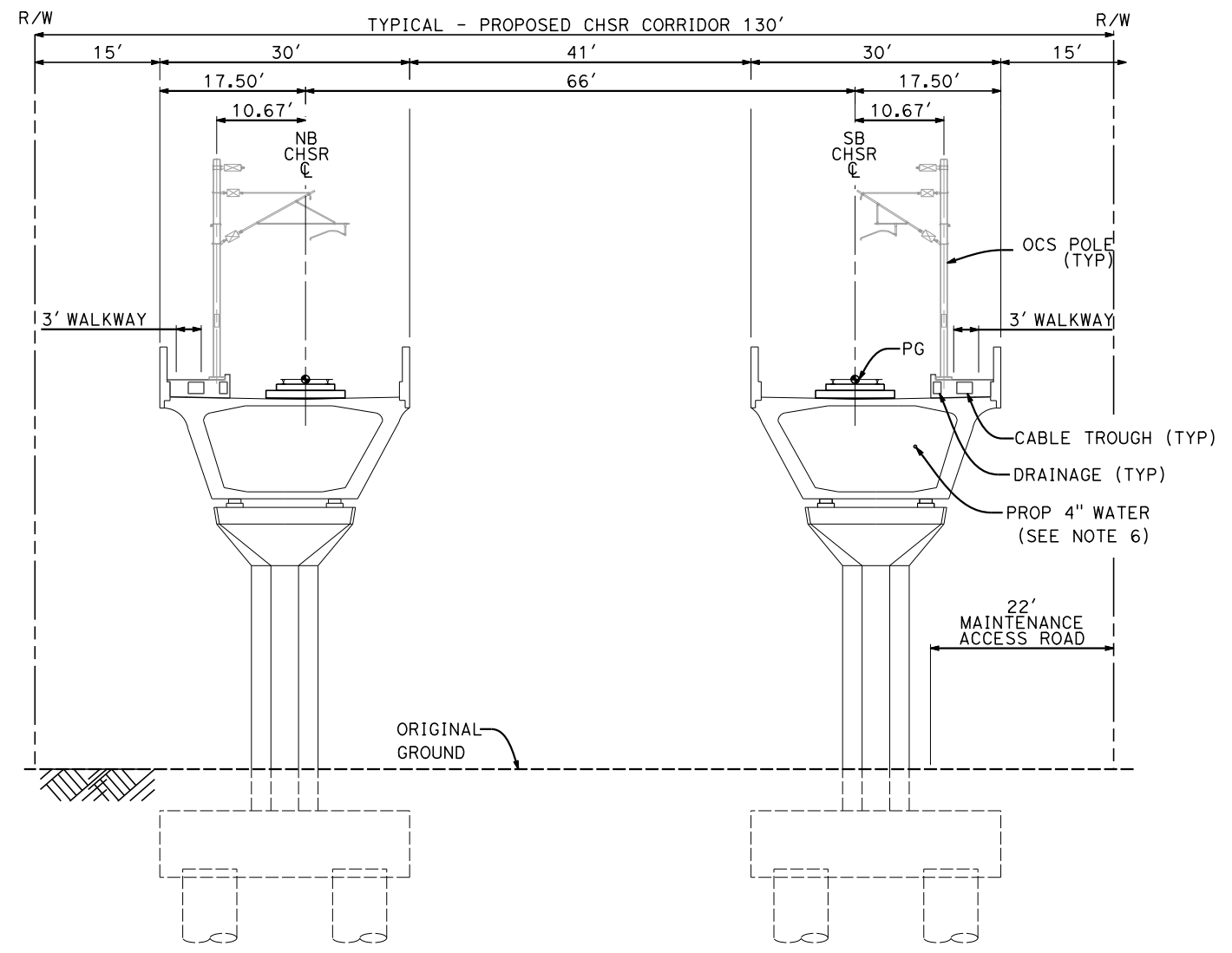

SECTION D

- STA 19097+53 TO 19104+40 (REFINED CCNM)

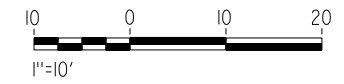

Projects\701206.00_CHSRBP\00_CADD\CCNM Option D\Sheets\TT\BP-TT-B3201.dgn

10:08:32 PM

1/22/2020

andrew.carson@tylin.com

REV	DATE	BY	CHK	APP	DESCRIPTION

DESIGNED BY
A. CARSON
DRAWN BY
A. CARSON
CHECKED BY
S. LANDOLT
IN CHARGE
G. CAMPBELL
DATE
01/24/2020

**RECORD
PEPD
SUBMITTAL**

**NOT FOR
CONSTRUCTION**



**CALIFORNIA HIGH-SPEED RAIL PROJECT
BAKERSFIELD TO PALMDALE**
REFINED CCNM DESIGN OPTION
TRACK GENERAL
TYPICAL SECTIONS
SHEET 1 OF 10

CONTRACT NO.
HSR13-44
DRAWING NO.
TT-B3201
SCALE
AS SHOWN
SHEET NO.

Projects\701206.00_CADD\CCNM Option D\Sheets\TT\BP-TT-B3202.dgn

10:08:49 PM

1/22/2020

andrew.carson@tylin.com

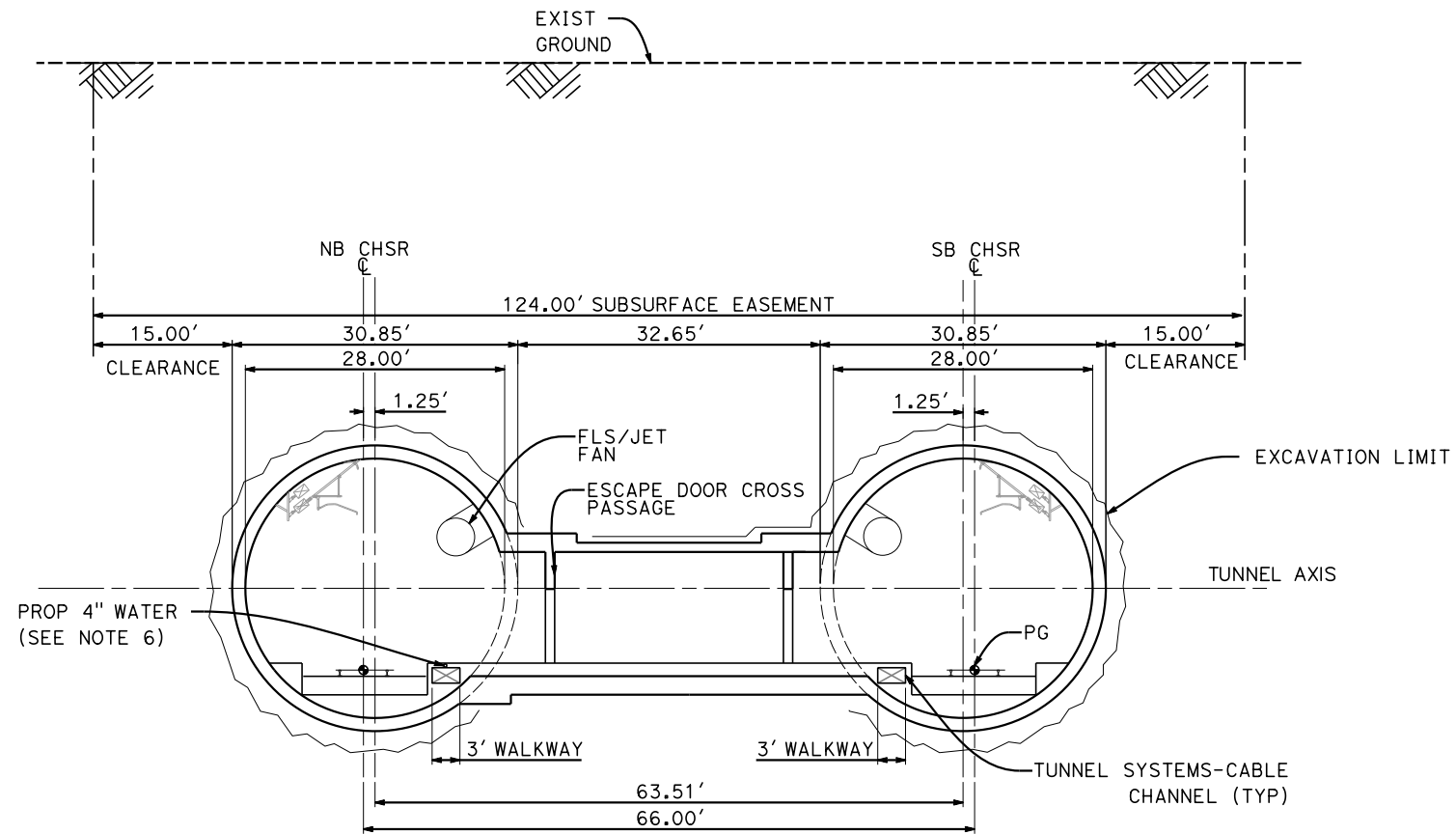

NOTES:

1. TRACKFORM SHOWN IS INDICATIVE
2. SUPERELEVATION IS NOT SHOWN. THE AMOUNT OF APPLIED SUPERELEVATION IS SHOWN IN THE CURVE TABLES ON SHEET TT-B0202
3. FOR STRUCTURAL DIMENSIONS SEE ST TYPICAL SECTIONS
4. FOR TUNNEL DETAILS SEE TN TYPICAL SECTIONS
5. FOR TRACTION POWER FACILITY DETAILS SEE TP TYPICAL SECTIONS
6. PROPOSED 4" WATER LINE PARALLELS ALIGNMENT FROM STATION 18034+00 TO 19591+00

SECTION G
TWIN TUNNEL - TUNNEL BORING MACHINE
STA 18940+84 TO 19019+33 (REFINED CCNM)

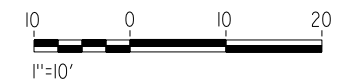

REV	DATE	BY	CHK	APP	DESCRIPTION

DESIGNED BY
A. CARSON
DRAWN BY
A. CARSON
CHECKED BY
S. LANDOLT
IN CHARGE
G. CAMPBELL
DATE
01/24/2020

**RECORD
PEPD
SUBMITTAL**

**NOT FOR
CONSTRUCTION**



CALIFORNIA HIGH-SPEED RAIL PROJECT
BAKERSFIELD TO PALMDALE
REFINED CCNM DESIGN OPTION
TRACK GENERAL
TYPICAL SECTIONS
SHEET 2 OF 10

CONTRACT NO.
HSR13-44
DRAWING NO.
TT-B3202
SCALE
AS SHOWN
SHEET NO.

NOTES:

1. TRACKFORM SHOWN IS INDICATIVE
2. SUPERELEVATION IS NOT SHOWN. THE AMOUNT OF APPLIED SUPERELEVATION IS SHOWN IN THE CURVE TABLES ON SHEET TT-B0202
3. FOR STRUCTURAL DIMENSIONS SEE ST TYPICAL SECTIONS
4. FOR TUNNEL DETAILS SEE TN TYPICAL SECTIONS
5. FOR TRACTION POWER FACILITY DETAILS SEE TP TYPICAL SECTIONS
6. PROPOSED 4" WATER LINE PARALLELS ALIGNMENT FROM STATION 18034+00 TO 19591+00

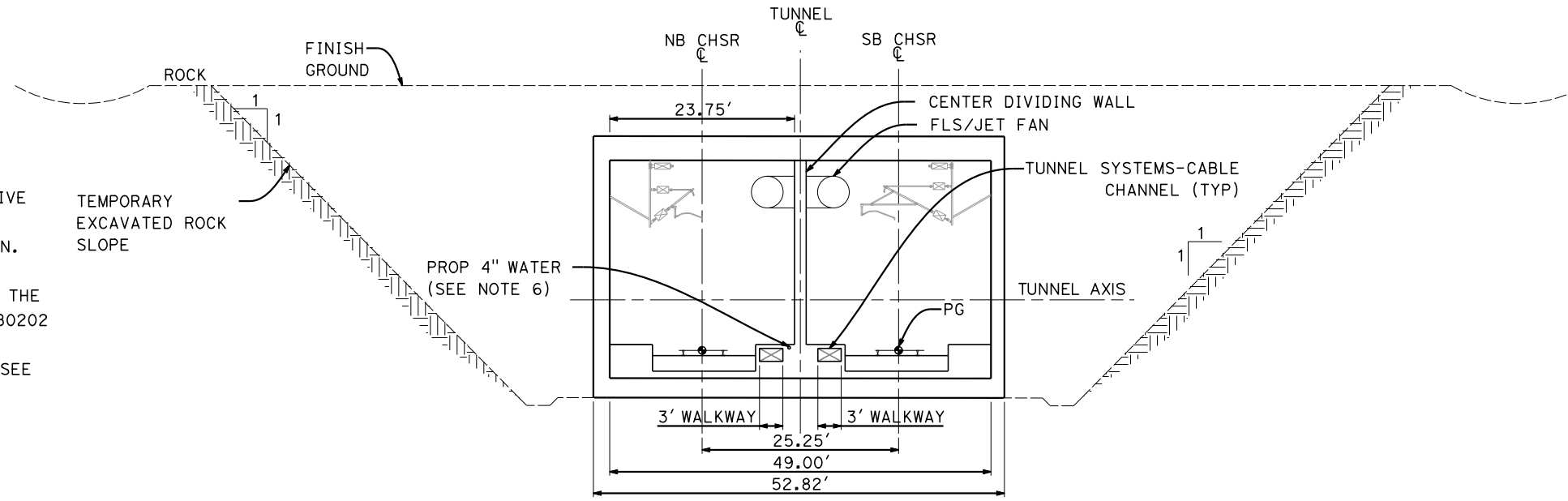

SECTION H
 SINGLE TUNNEL - CUT AND COVER
 STA 18362+50 TO 18368+50 (REFINED CCNM)

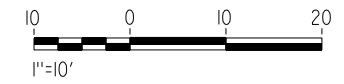

REV	DATE	BY	CHK	APP	DESCRIPTION

DESIGNED BY
A. CARSON
 DRAWN BY
A. CARSON
 CHECKED BY
S. LANDOLT
 IN CHARGE
G. CAMPBELL
 DATE
01/24/2020

**RECORD
 PEPD
 SUBMITTAL**

**NOT FOR
 CONSTRUCTION**



**CALIFORNIA HIGH-SPEED RAIL PROJECT
 BAKERSFIELD TO PALMDALE**
 REFINED CCNM DESIGN OPTION
 TRACK GENERAL
 TYPICAL SECTIONS
 SHEET 3 OF 10

CONTRACT NO.
HSR13-44
 DRAWING NO.
TT-B3203
 SCALE
AS SHOWN
 SHEET NO.

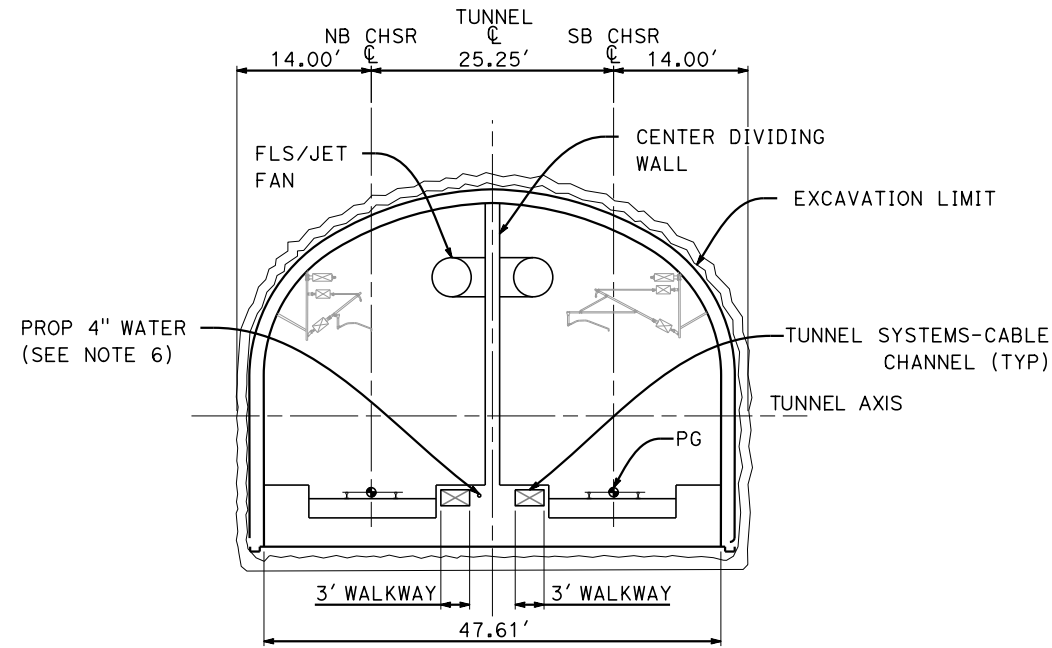

SECTION J
SINGLE TUNNEL - DRILL AND BLAST

STA 18368+50 TO 18422+90 (REFINED CCNM)
 STA 18524+76 TO 18566+93 (REFINED CCNM)
 STA 18617+53 TO 18706+84 (REFINED CCNM)

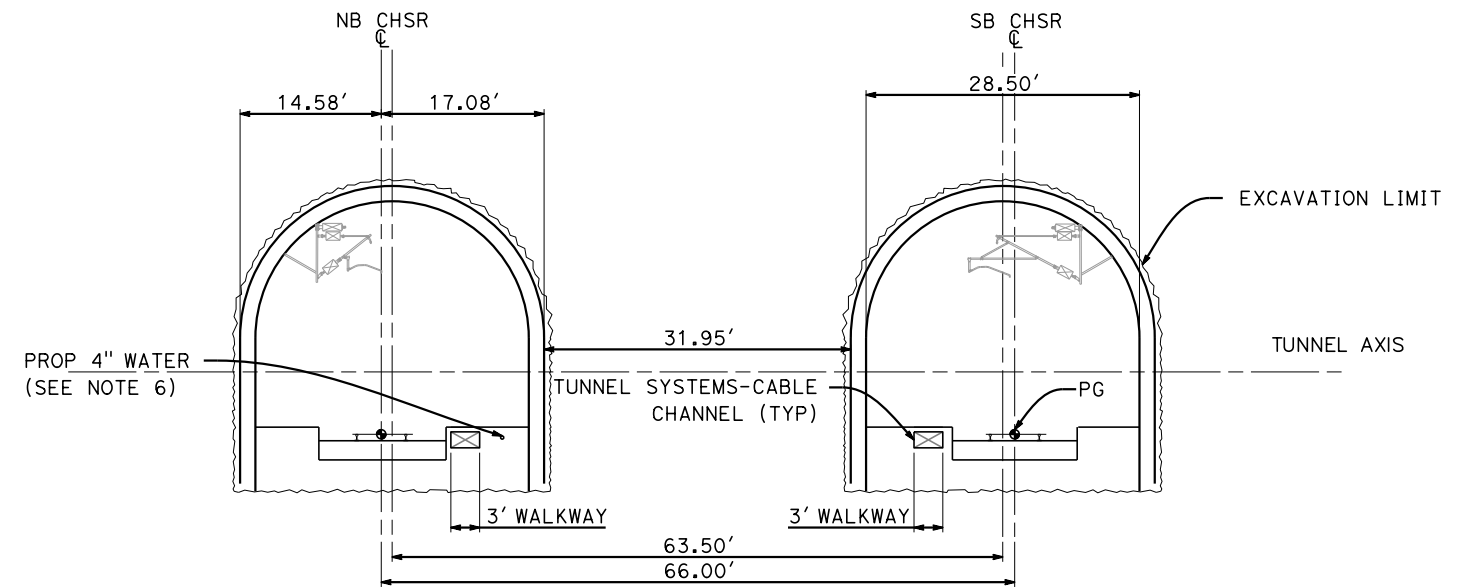

SECTION K
TWIN TUNNEL - DRILL AND BLAST

STA 18930+70 TO 18940+84 (REFINED CCNM)

NOTES:

1. TRACKFORM SHOWN IS INDICATIVE
2. SUPERELEVATION IS NOT SHOWN. THE AMOUNT OF APPLIED SUPERELEVATION IS SHOWN IN THE CURVE TABLES ON SHEET TT-B0202
3. FOR STRUCTURAL DIMENSIONS SEE ST TYPICAL SECTIONS
4. FOR TUNNEL DETAILS SEE TN TYPICAL SECTIONS
5. FOR TRACTION POWER FACILITY DETAILS SEE TP TYPICAL SECTIONS
6. PROPOSED 4" WATER LINE PARALLELS ALIGNMENT FROM STATION 18034+00 TO 19591+00



REV	DATE	BY	CHK	APP	DESCRIPTION

DESIGNED BY A. CARSON
DRAWN BY A. CARSON
CHECKED BY S. LANDOLT
IN CHARGE G. CAMPBELL
DATE 01/24/2020

**RECORD
PEPD
SUBMITTAL**

**NOT FOR
CONSTRUCTION**



**CALIFORNIA HIGH-SPEED RAIL PROJECT
 BAKERSFIELD TO PALMDALE**
 REFINED CCNM DESIGN OPTION
 TRACK GENERAL
 TYPICAL SECTIONS
 SHEET 4 OF 10

CONTRACT NO. HSR13-44
DRAWING NO. TT-B3204
SCALE AS SHOWN
SHEET NO.

Projects\701206.00_CADD\CCNM Option D\Sheets\TT\BP-TT-B3205.dgn

9:57:38 PM

1/22/2020

andrew.carson@tylin.com

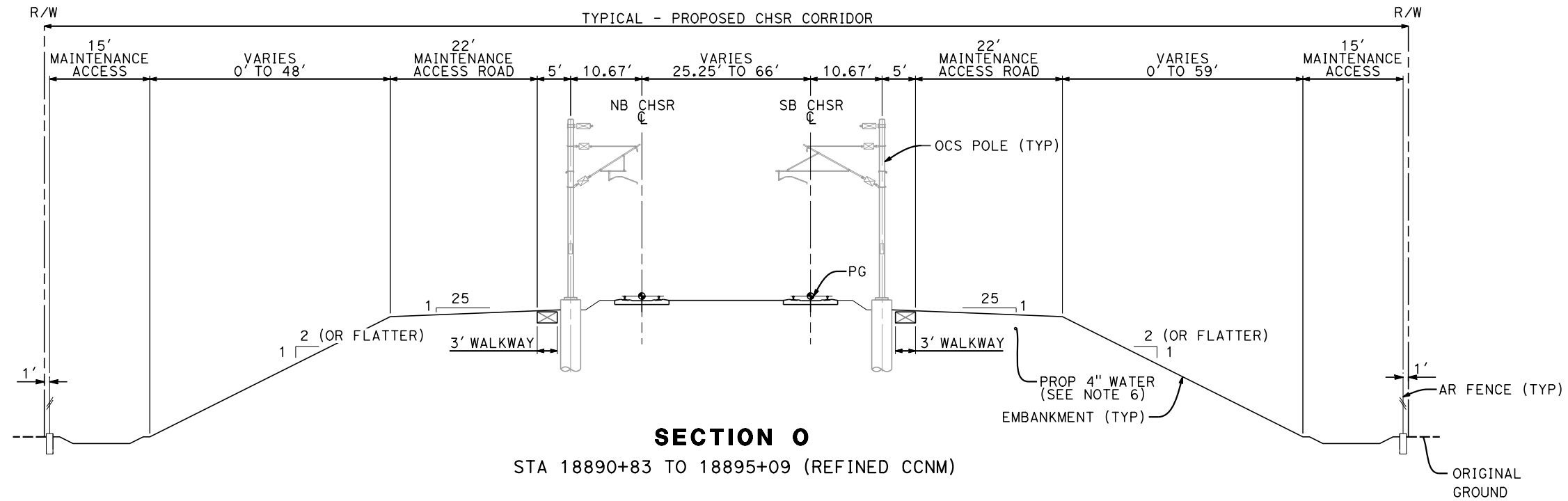

NOTES:

1. TRACKFORM SHOWN IS INDICATIVE
2. SUPERELEVATION IS NOT SHOWN. THE AMOUNT OF APPLIED SUPERELEVATION IS SHOWN IN THE CURVE TABLES ON SHEET TT-B0202
3. FOR STRUCTURAL DIMENSIONS SEE ST TYPICAL SECTIONS
4. FOR TUNNEL DETAILS SEE TN TYPICAL SECTIONS
5. FOR TRACTION POWER FACILITY DETAILS SEE TP TYPICAL SECTIONS
6. PROPOSED 4" WATER LINE PARALLELS ALIGNMENT FROM STATION 18034+00 TO 18591+00

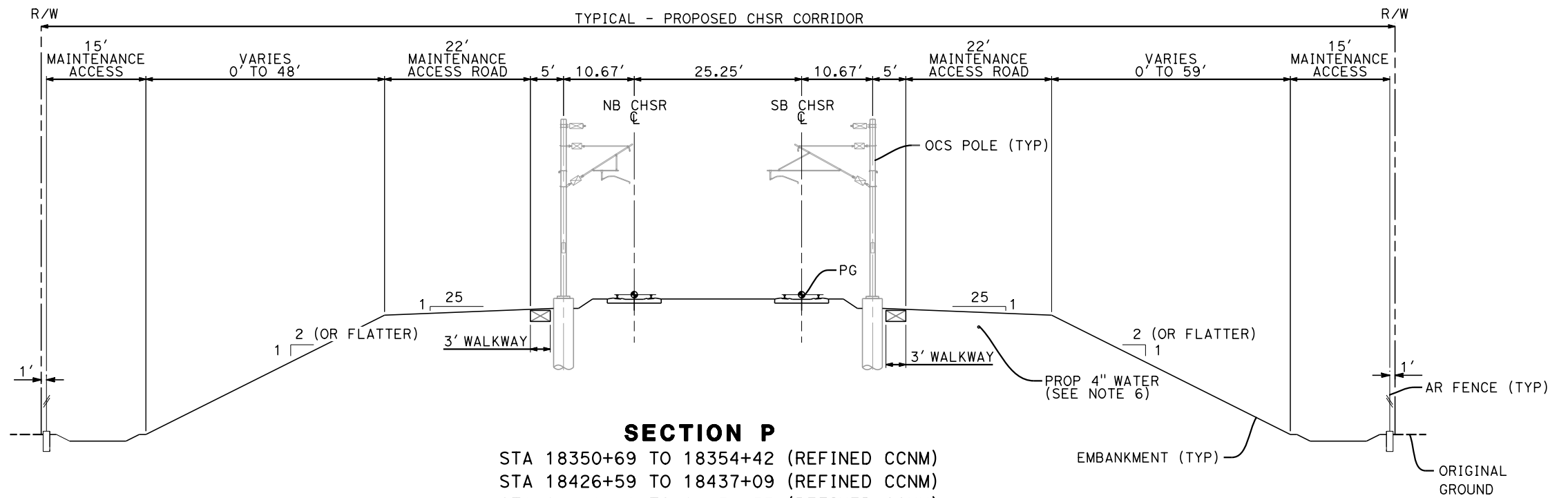

- SECTION P**
- STA 18350+69 TO 18354+42 (REFINED CCNM)
 - STA 18426+59 TO 18437+09 (REFINED CCNM)
 - STA 18449+09 TO 18454+53 (REFINED CCNM)
 - STA 18456+94 TO 18465+50 (REFINED CCNM)
 - STA 18475+65 TO 18477+49 (REFINED CCNM)
 - STA 18486+94 TO 18491+62 (REFINED CCNM)
 - STA 18493+45 TO 18495+00 (REFINED CCNM)
 - STA 18584+81 TO 18597+24 (REFINED CCNM)
 - STA 18738+45 TO 18744+33 (REFINED CCNM)



REV	DATE	BY	CHK	APP	DESCRIPTION

DESIGNED BY A. CARSON
DRAWN BY A. CARSON
CHECKED BY S. LANDOLT
IN CHARGE G. CAMPBELL
DATE 01/24/2020

**RECORD
PEPD
SUBMITTAL**

**NOT FOR
CONSTRUCTION**



**CALIFORNIA HIGH-SPEED RAIL PROJECT
BAKERSFIELD TO PALMDALE**

REFINED CCNM DESIGN OPTION
TRACK GENERAL
TYPICAL SECTIONS
SHEET 5 OF 10

CONTRACT NO. HSR13-44
DRAWING NO. TT-B3205
SCALE AS SHOWN
SHEET NO.

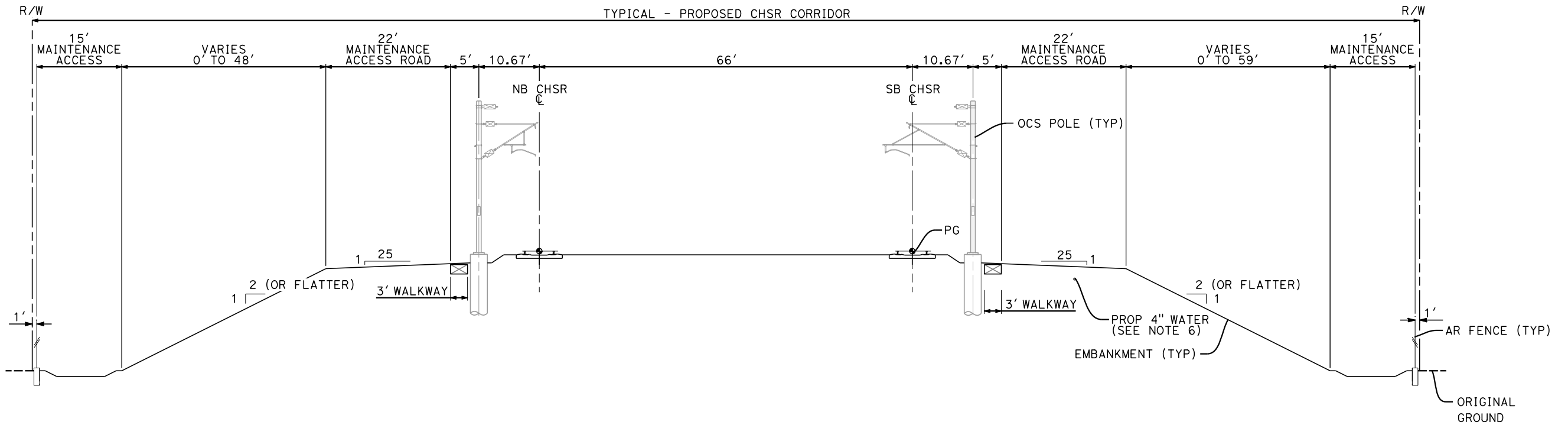

NOTES:

1. TRACKFORM SHOWN IS INDICATIVE
2. SUPERELEVATION IS NOT SHOWN. THE AMOUNT OF APPLIED SUPERELEVATION IS SHOWN IN THE CURVE TABLES ON SHEET TT-B0202
3. FOR STRUCTURAL DIMENSIONS SEE ST TYPICAL SECTIONS
4. FOR TUNNEL DETAILS SEE TN TYPICAL SECTIONS
5. FOR TRACTION POWER FACILITY DETAILS SEE TP TYPICAL SECTIONS
6. PROPOSED 4" WATER LINE PARALLELS ALIGNMENT FROM STATION 18034+00 TO 19591+00

SECTION Q
STA 19058+90 TO 19097+53 (REFINED CCNM)



Projects\701206.00_CADD\CCNM Option D\Sheets\TT\BP-TT-B3206.dgn

10:09:13 PM

1/22/2020

andrew.carson@tylin.com

REV	DATE	BY	CHK	APP	DESCRIPTION

DESIGNED BY
A. CARSON
DRAWN BY
A. CARSON
CHECKED BY
S. LANDOLT
IN CHARGE
G. CAMPBELL
DATE
01/24/2020

**RECORD
PEPD
SUBMITTAL**

**NOT FOR
CONSTRUCTION**

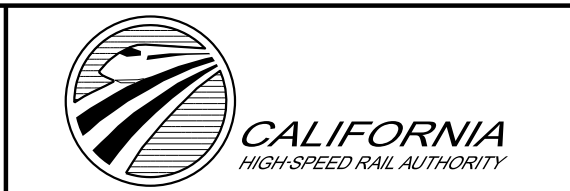

**CALIFORNIA HIGH-SPEED RAIL PROJECT
BAKERSFIELD TO PALMDALE**
REFINED CCNM DESIGN OPTION
TRACK GENERAL
TYPICAL SECTIONS
SHEET 6 OF 10

CONTRACT NO.
HSR13-44
DRAWING NO.
TT-B3206
SCALE
AS SHOWN
SHEET NO.

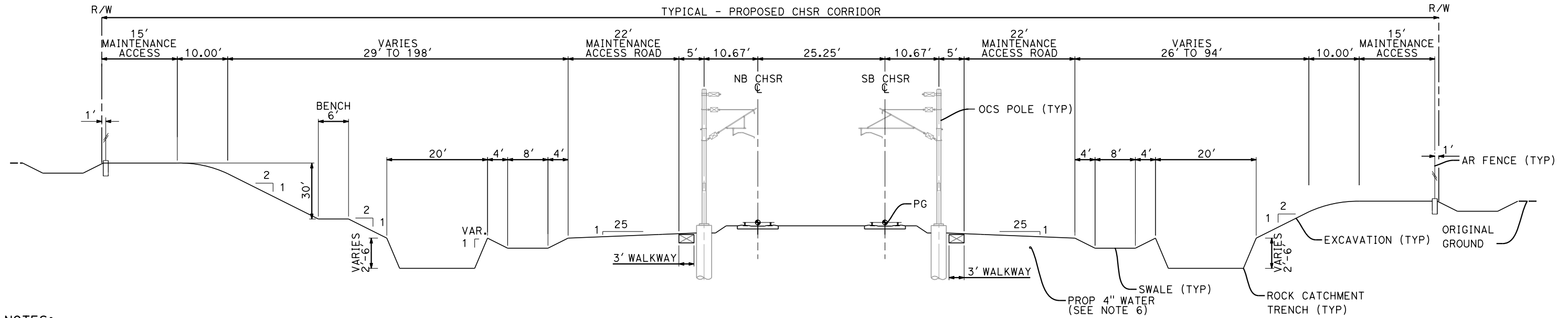

NOTES:

1. TRACKFORM SHOWN IS INDICATIVE
2. SUPERELEVATION IS NOT SHOWN. THE AMOUNT OF APPLIED SUPERELEVATION IS SHOWN IN THE CURVE TABLES ON SHEET TT-B0202
3. FOR STRUCTURAL DIMENSIONS SEE ST TYPICAL SECTIONS
4. FOR TUNNEL DETAILS SEE TN TYPICAL SECTIONS
5. FOR TRACTION POWER FACILITY DETAILS SEE TP TYPICAL SECTIONS
6. PROPOSED 4" WATER LINE PARALLELS ALIGNMENT FROM STATION 18034+00 TO 19591+00

SECTION S

- STA 18307+67 TO 18350+69 (REFINED CCNM)
- STA 18354+42 TO 18362+50 (REFINED CCNM)
- STA 18422+90 TO 18426+59 (REFINED CCNM)
- STA 18437+09 TO 18449+09 (REFINED CCNM)
- STA 18454+53 TO 18456+94 (REFINED CCNM)
- STA 18477+49 TO 18486+94 (REFINED CCNM)
- STA 18495+00 TO 18524+76 (REFINED CCNM)
- STA 18566+93 TO 18584+81 (REFINED CCNM)
- STA 18603+56 TO 18617+53 (REFINED CCNM)
- STA 18706+84 TO 18738+45 (REFINED CCNM)
- STA 18813+16 TO 18838+59 (REFINED CCNM)
- STA 18884+25 TO 18890+83 (REFINED CCNM)



REV	DATE	BY	CHK	APP	DESCRIPTION

DESIGNED BY A. CARSON
DRAWN BY A. CARSON
CHECKED BY S. LANDOLT
IN CHARGE G. CAMPBELL
DATE 01/24/2020

**RECORD
PEPD
SUBMITTAL**

**NOT FOR
CONSTRUCTION**

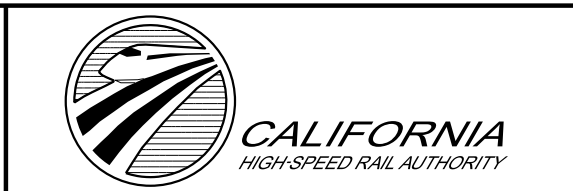

**CALIFORNIA HIGH-SPEED RAIL PROJECT
BAKERSFIELD TO PALMDALE**

REFINED CCNM DESIGN OPTION
TRACK GENERAL
TYPICAL SECTIONS
SHEET 7 OF 10

CONTRACT NO. HSR13-44
DRAWING NO. TT-B3207
SCALE AS SHOWN
SHEET NO.

Projects\701206.00_CADD\CCNM Option D\Sheets\TT\BP-TT-B3208.dgn

10:08:43 PM

1/22/2020

andrew.carson@tylin.com

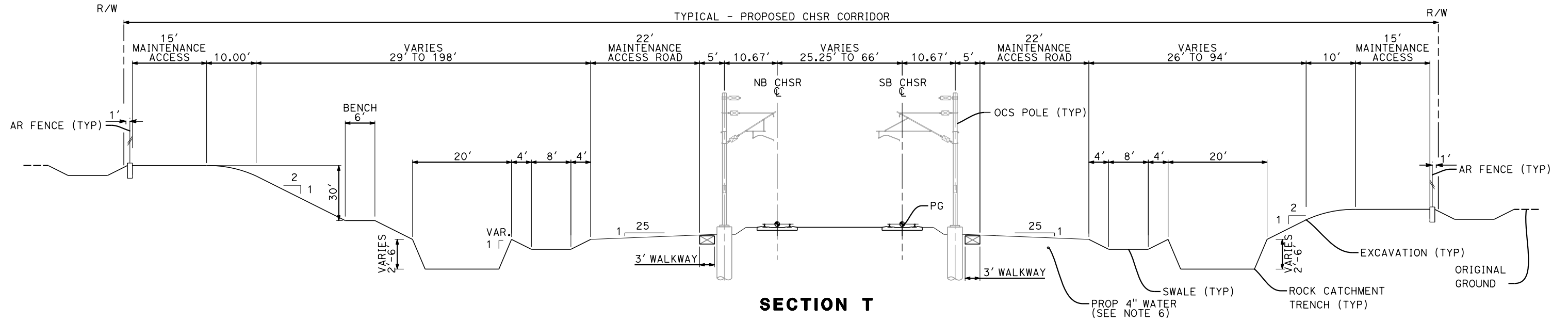

SECTION T
STA 18895+09 TO 18930+70 (REFINED CCNM)

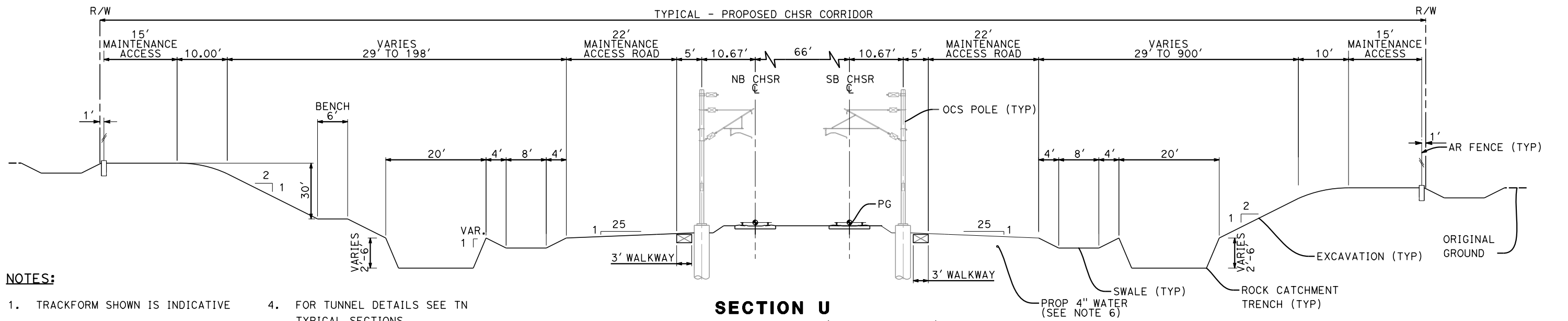

SECTION U
STA 19019+33 TO 19058+90 (REFINED CCNM)

NOTES:

1. TRACKFORM SHOWN IS INDICATIVE
2. SUPERELEVATION IS NOT SHOWN. THE AMOUNT OF APPLIED SUPERELEVATION IS SHOWN IN THE CURVE TABLES ON SHEET TT-B0202
3. FOR STRUCTURAL DIMENSIONS SEE ST TYPICAL SECTIONS
4. FOR TUNNEL DETAILS SEE TN TYPICAL SECTIONS
5. FOR TRACTION POWER FACILITY DETAILS SEE TP TYPICAL SECTIONS
6. PROPOSED 4" WATER LINE PARALLELS ALIGNMENT FROM STATION 18034+00 TO 19591+00



REV	DATE	BY	CHK	APP	DESCRIPTION

DESIGNED BY
A. CARSON
DRAWN BY
A. CARSON
CHECKED BY
S. LANDOLT
IN CHARGE
G. CAMPBELL
DATE
01/24/2020

**RECORD
PEPD
SUBMITTAL**

**NOT FOR
CONSTRUCTION**



**CALIFORNIA HIGH-SPEED RAIL PROJECT
BAKERSFIELD TO PALMDALE**
REFINED CCNM DESIGN OPTION
TRACK GENERAL
TYPICAL SECTIONS
SHEET 8 OF 10

CONTRACT NO.
HSR13-44
DRAWING NO.
TT-B3208
SCALE
AS SHOWN
SHEET NO.

Projects\701206.00_CADD\CCNM Option D\Sheets\TT\BP-TT-B3209.dgn

9:58:28 PM

1/22/2020

andrew.carson@tylin.com

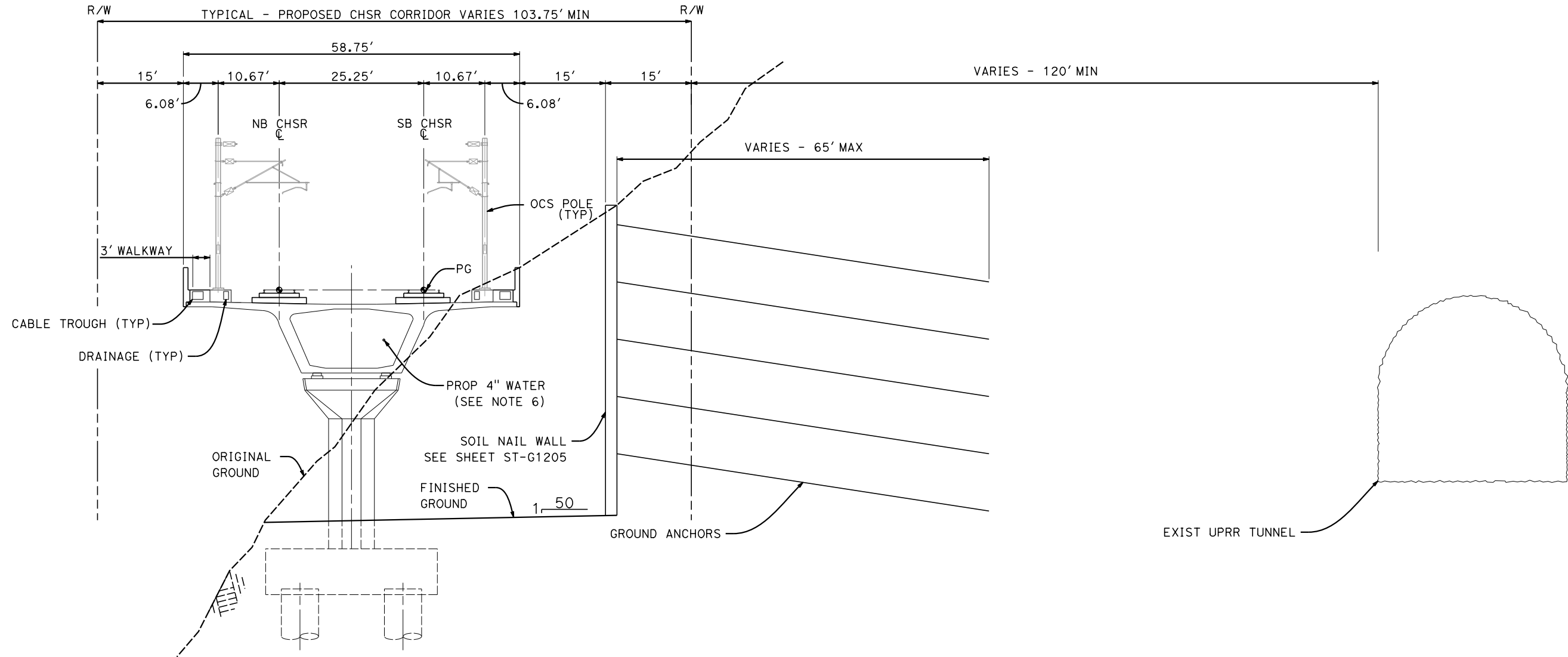

SECTION AC

STA 18850+78 to 18853+14 (REFINED CCNM)

NOTES:

1. TRACKFORM SHOWN IS INDICATIVE
2. SUPERELEVATION IS NOT SHOWN. THE AMOUNT OF APPLIED SUPERELEVATION IS SHOWN IN THE CURVE TABLES ON SHEET TT-B0202
3. FOR STRUCTURAL DIMENSIONS SEE ST TYPICAL SECTIONS
4. FOR TUNNEL DETAILS SEE TN TYPICAL SECTIONS
5. FOR TRACTION POWER FACILITY DETAILS SEE TP TYPICAL SECTIONS
6. PROPOSED 4" WATER LINE PARALLELS ALIGNMENT FROM STATION 18034+00 TO 19591+00



REV	DATE	BY	CHK	APP	DESCRIPTION

DESIGNED BY
A. CARSON
DRAWN BY
A. CARSON
CHECKED BY
S. LANDOLT
IN CHARGE
G. CAMPBELL
DATE
01/24/2020

**RECORD
PEPD
SUBMITTAL**

**NOT FOR
CONSTRUCTION**



**CALIFORNIA HIGH-SPEED RAIL PROJECT
BAKERSFIELD TO PALMDALE**
REFINED CCNM DESIGN OPTION
TRACK GENERAL
TYPICAL SECTIONS
SHEET 9 OF 10

CONTRACT NO.
HSR13-44
DRAWING NO.
TT-B3209
SCALE
AS SHOWN
SHEET NO.

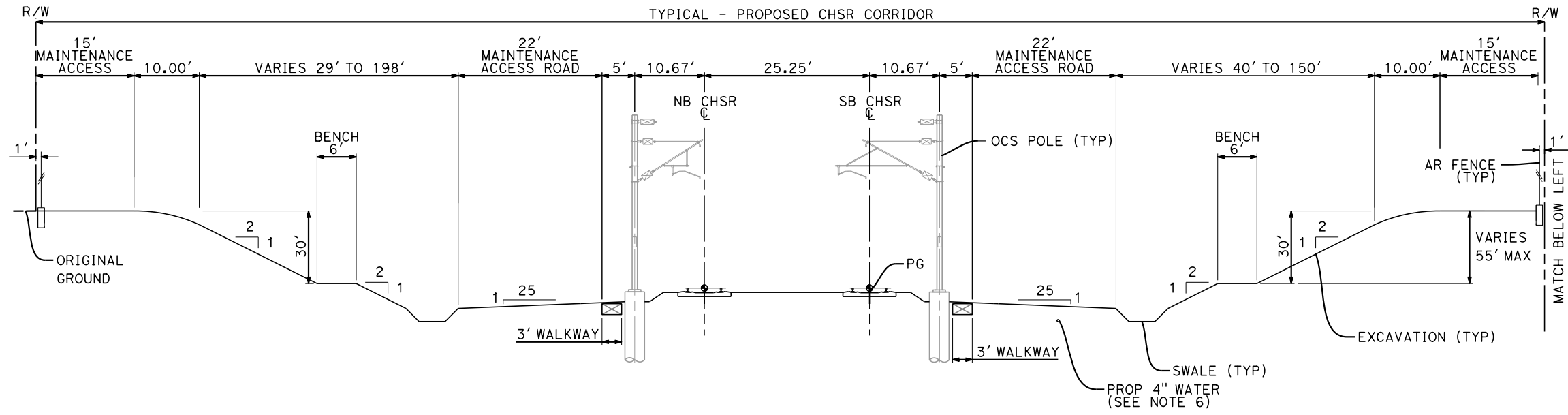

SECTION AD
STA 18746+98 TO 18813+16 (REFINED CCNM)

NOTES:

1. TRACKFORM SHOWN IS INDICATIVE
2. SUPERELEVATION IS NOT SHOWN. THE AMOUNT OF APPLIED SUPERELEVATION IS SHOWN IN THE CURVE TABLES ON SHEET TT-B0202
3. FOR STRUCTURAL DIMENSIONS SEE ST TYPICAL SECTIONS
4. FOR TUNNEL DETAILS SEE TN TYPICAL SECTIONS
5. FOR TRACTION POWER FACILITY DETAILS SEE TP TYPICAL SECTIONS
6. PROPOSED 4" WATER LINE PARALLELS ALIGNMENT FROM STATION 18034+00 TO 19591+00
7. PER CALTRANS HIGHWAY DESING MANUAL HORIZONTAL CLEARANCE FROM ETW SHALL BE 52' MINIMUM.

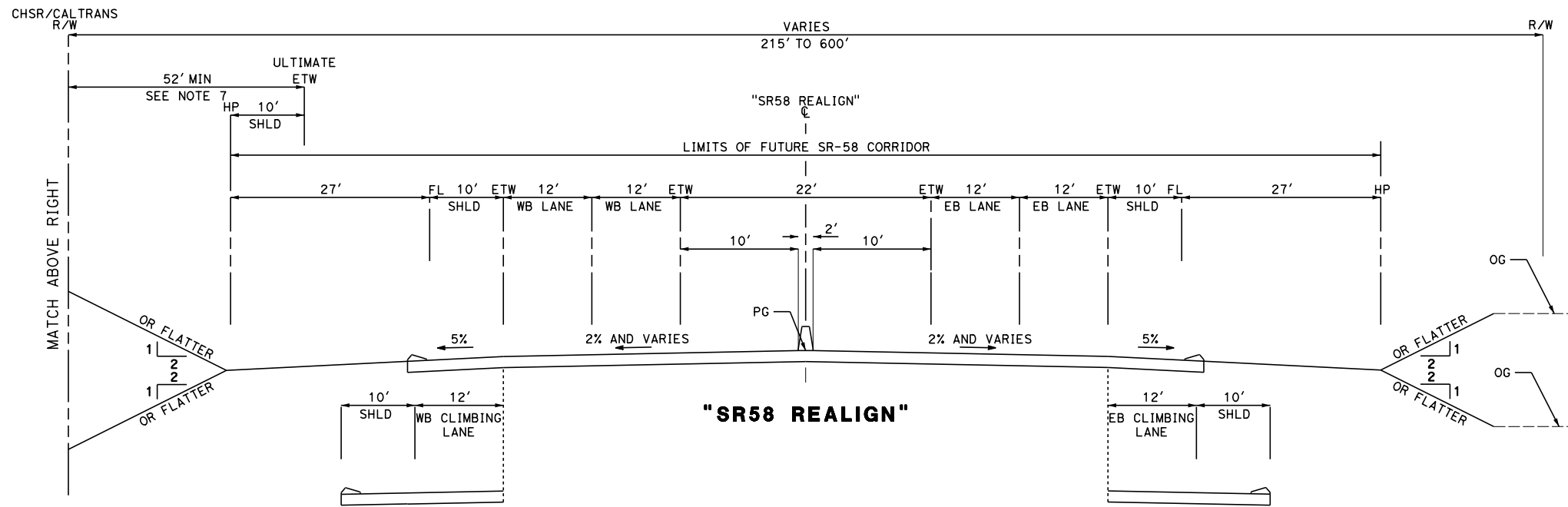

Projects\701206.00_CADD\CCNM Option D\Sheets\TT\BP-TT-B3210.dgn

11:49:50 PM

1/22/2020

andrew.carson@tylin.com

REV	DATE	BY	CHK	APP	DESCRIPTION

DESIGNED BY
A. CARSON
DRAWN BY
A. CARSON
CHECKED BY
S. LANDOLT
IN CHARGE
G. CAMPBELL
DATE
01/24/2020

**RECORD
PEPD
SUBMITTAL**

**NOT FOR
CONSTRUCTION**



CALIFORNIA HIGH-SPEED RAIL PROJECT
BAKERSFIELD TO PALMDALE
REFINED CCNM DESIGN OPTION
TRACK GENERAL
TYPICAL SECTIONS
SHEET 10 OF 10

CONTRACT NO.
HSR13-44
DRAWING NO.
TT-B3210
SCALE
AS SHOWN
SHEET NO.

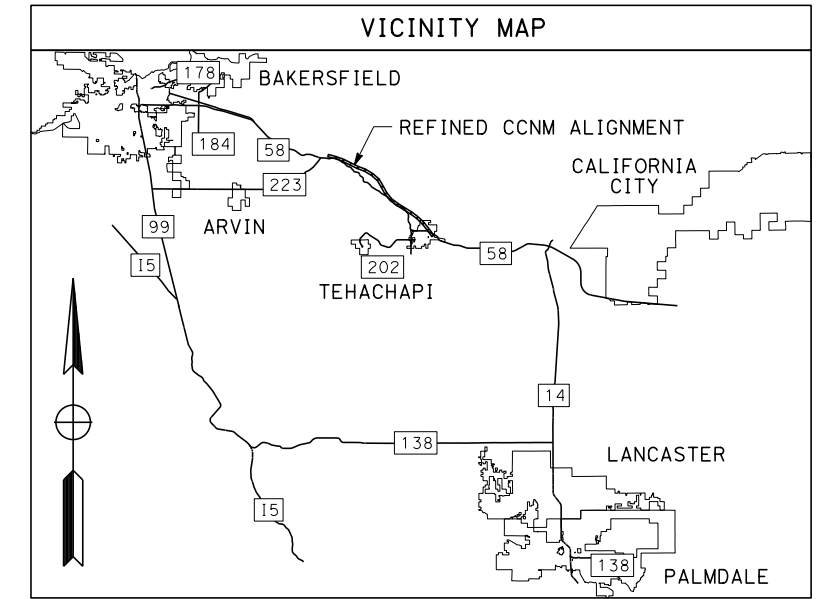

REFINED CCNM DESIGN OPTION

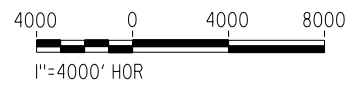
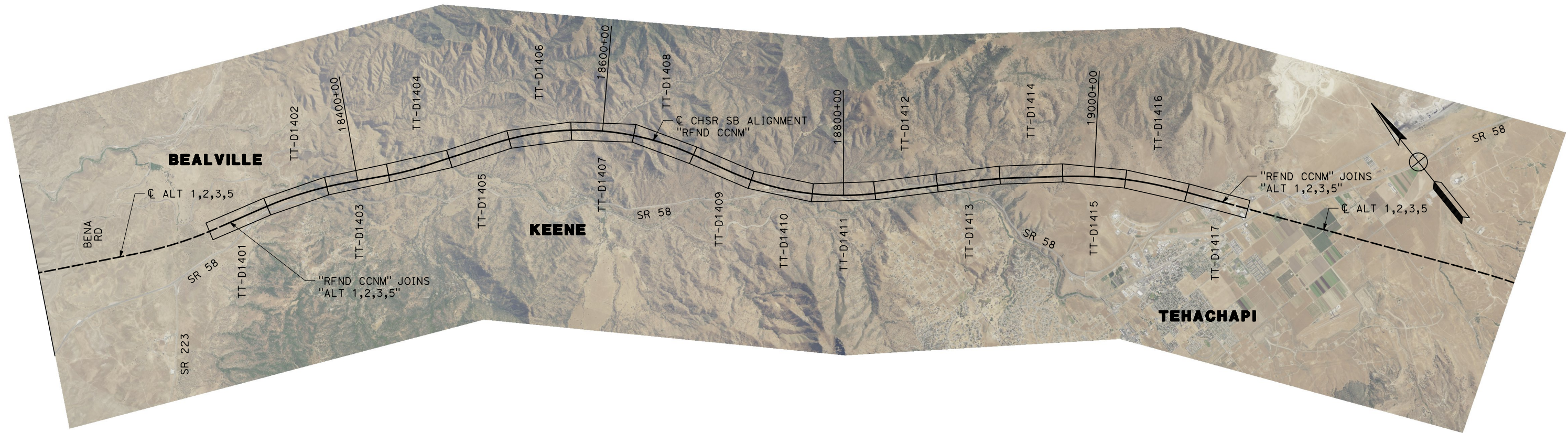

REV	DATE	BY	CHK	APP	DESCRIPTION

DESIGNED BY
A. CARSON
DRAWN BY
A. CARSON
CHECKED BY
S. LANDOLT
IN CHARGE
G. CAMPBELL
DATE
01/24/2020

**RECORD
PEPD
SUBMITTAL**

**NOT FOR
CONSTRUCTION**



CALIFORNIA HIGH-SPEED RAIL PROJECT
BAKERSFIELD TO PALMDALE
REFINED CCNM DESIGN OPTION
TRACK GENERAL
KEY MAP

CONTRACT NO.
HSR13-44
DRAWING NO.
TT-C6201
SCALE
NO SCALE
SHEET NO.

Projects\701206.00_CADD\CCNM Option D\Sheets\TT-BP-TT-D1401.dgn
 1/22/2020 9:56:14 PM
 andrew.carson@tylin.com

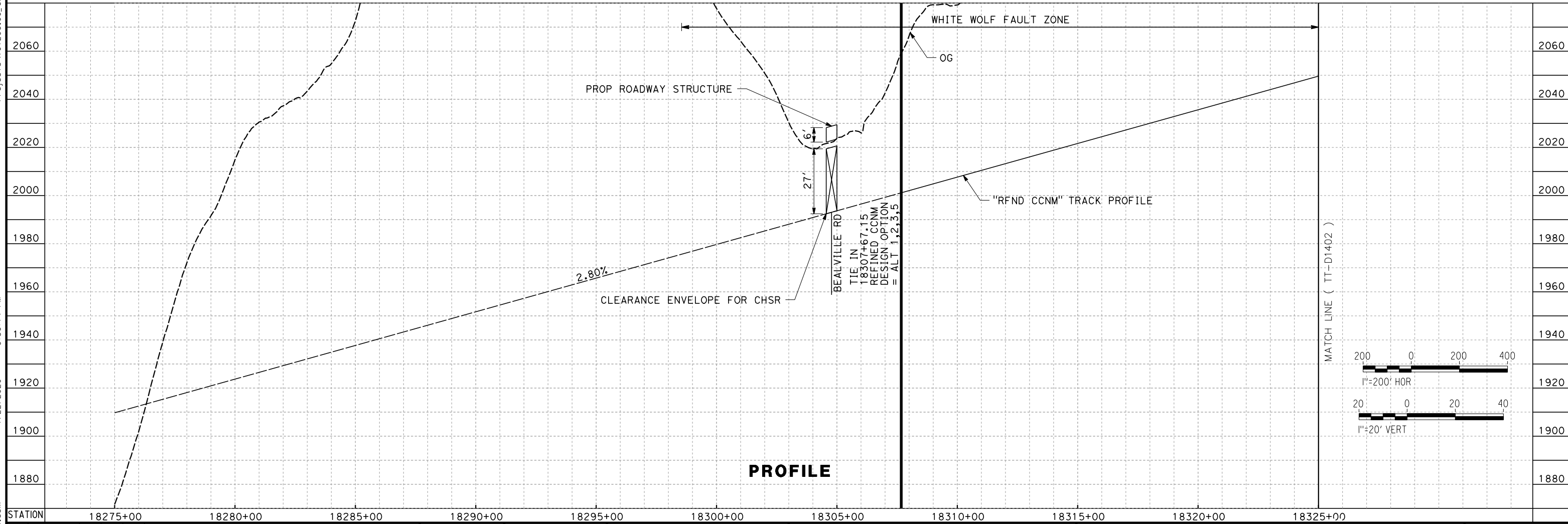
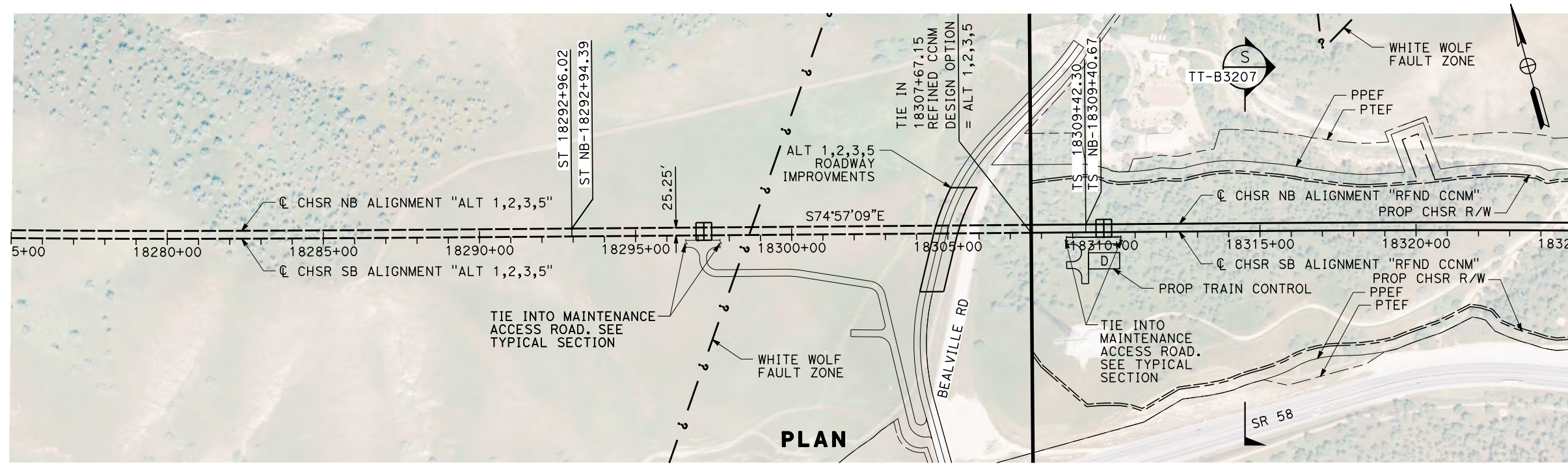

REV	DATE	BY	CHK	APP	DESCRIPTION

DESIGNED BY
A. CARSON
 DRAWN BY
A. CARSON
 CHECKED BY
S. LANDOLT
 IN CHARGE
G. CAMPBELL
 DATE
01/24/2020

**RECORD
 PECD
 SUBMITTAL**

**NOT FOR
 CONSTRUCTION**



CALIFORNIA HIGH-SPEED RAIL PROJECT
BAKERSFIELD TO PALMDALE
 REFINED CCNM DESIGN OPTION
 TRACK GUIDEWAY
 STA 18275+00 TO 18325+00
 PLAN AND PROFILE

CONTRACT NO.
HSR13-44
 DRAWING NO.
TT-D1401
 SCALE
AS SHOWN
 SHEET NO.

Projects\701206_00_CHSRBP\00_CADD\CCNM Option D\Sheets\TT-NP-TT-D1402.dgn
 1/22/2020 10:06:30 PM andrew.carson@tylin.com

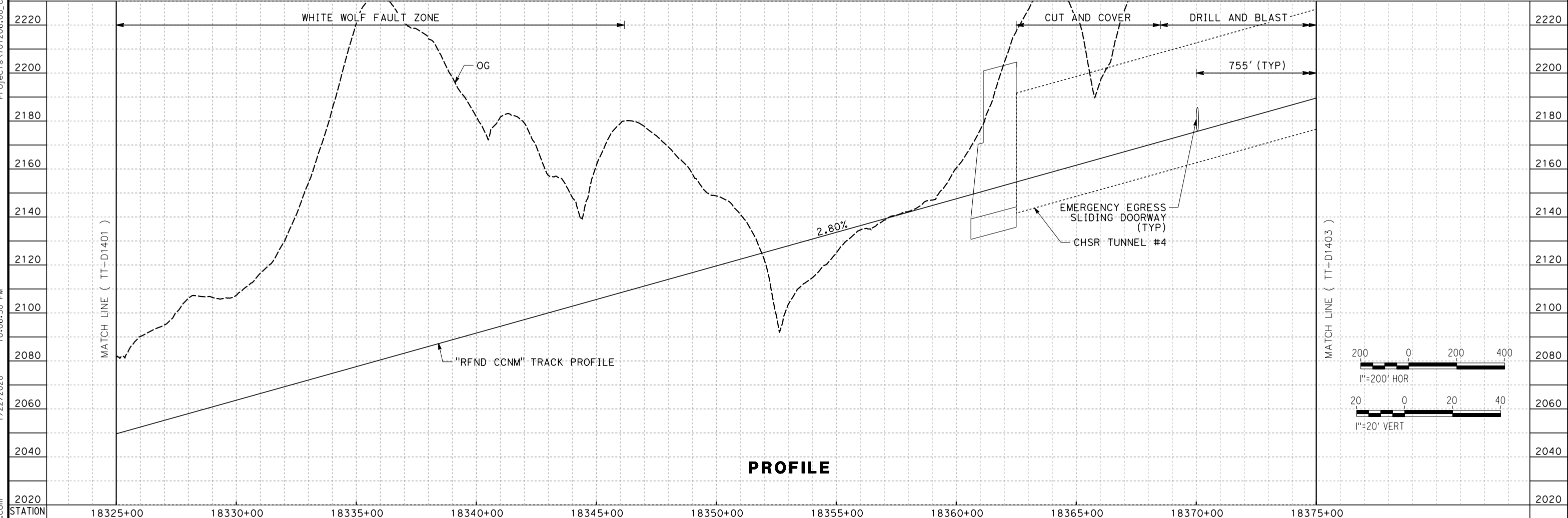
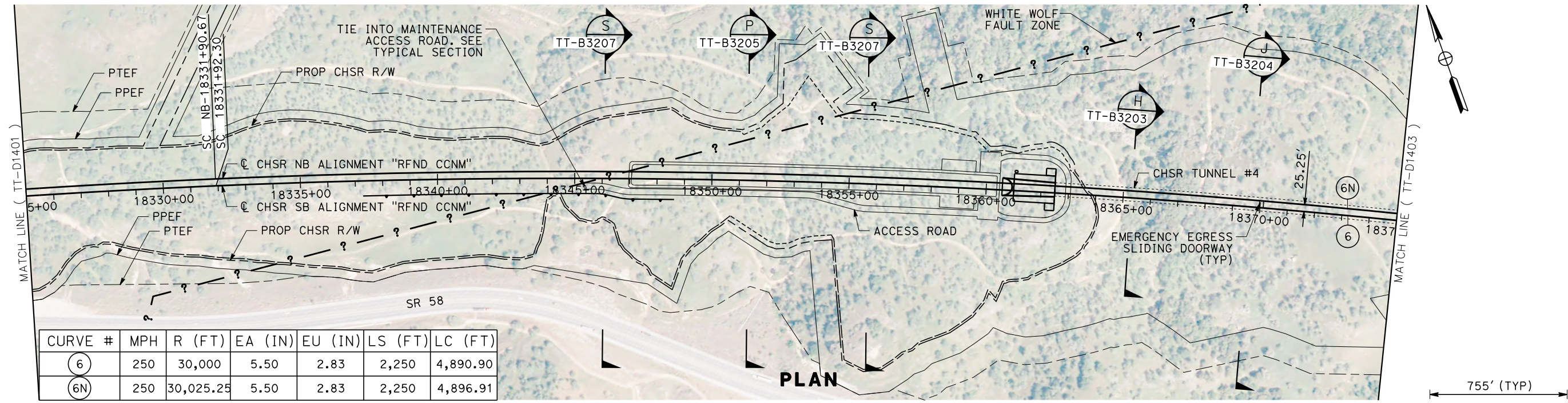

REV	DATE	BY	CHK	APP	DESCRIPTION

DESIGNED BY
A. CARSON
 DRAWN BY
A. CARSON
 CHECKED BY
S. LANDOLT
 IN CHARGE
G. CAMPBELL
 DATE
01/24/2020

**RECORD
 PECD
 SUBMITTAL**

**NOT FOR
 CONSTRUCTION**



CALIFORNIA HIGH-SPEED RAIL PROJECT
BAKERSFIELD TO PALMDALE
 REFINED CCNM DESIGN OPTION
 TRACK GUIDEWAY
 STA 18325+00 TO 18375+00
 PLAN AND PROFILE

CONTRACT NO.
HSR13-44
 DRAWING NO.
TT-D1402
 SCALE
AS SHOWN
 SHEET NO.

Projects\701206_00_CHSRBP\00_CADD\CCNM Option D\Sheets\TT-NP-TT-D1403.dgn

1/22/2020 9:55:51 PM

andrew.carson@tylin.com

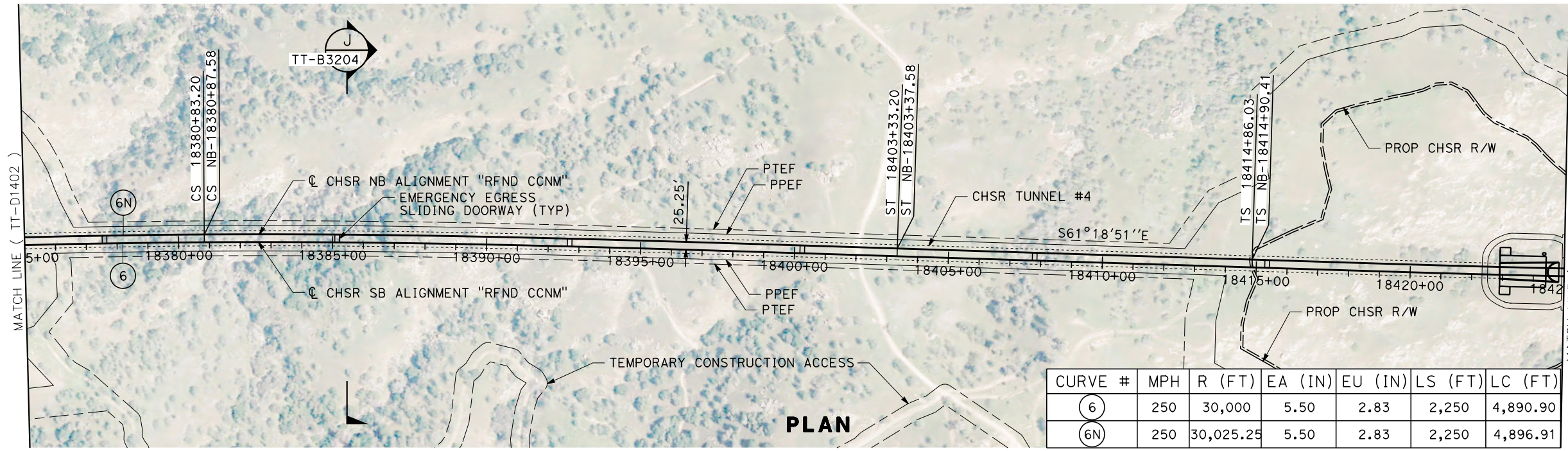

CURVE #	MPH	R (FT)	EA (IN)	EU (IN)	LS (FT)	LC (FT)
6	250	30,000	5.50	2.83	2,250	4,890.90
6N	250	30,025.25	5.50	2.83	2,250	4,896.91

PLAN

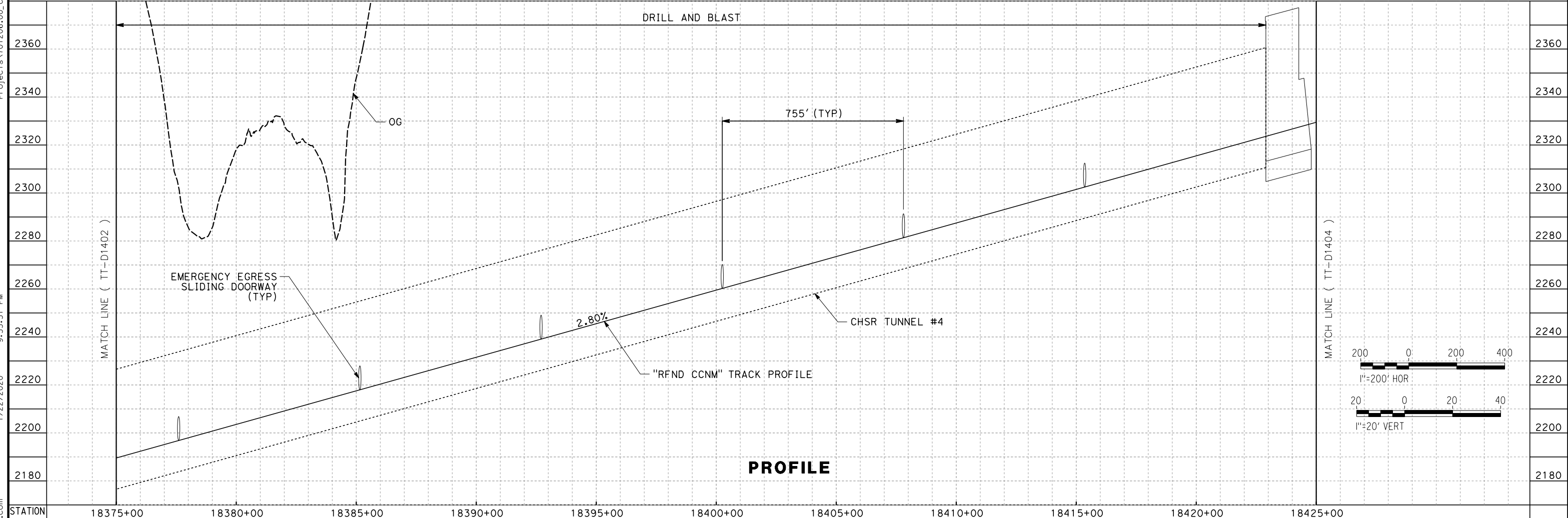
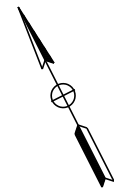

PROFILE

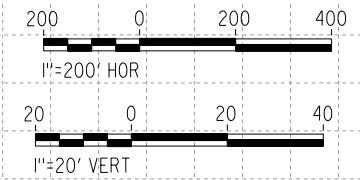

REV	DATE	BY	CHK	APP	DESCRIPTION

DESIGNED BY
A. CARSON
DRAWN BY
A. CARSON
CHECKED BY
S. LANDOLT
IN CHARGE
G. CAMPBELL
DATE
01/24/2020

**RECORD
PEPD
SUBMITTAL**

**NOT FOR
CONSTRUCTION**



CALIFORNIA HIGH-SPEED RAIL PROJECT
BAKERSFIELD TO PALMDALE
REFINED CCNM DESIGN OPTION
TRACK GUIDEWAY
STA 18375+00 TO 18425+00
PLAN AND PROFILE

CONTRACT NO.
HSR13-44
DRAWING NO.
TT-D1403
SCALE
AS SHOWN
SHEET NO.

Projects\701206_00_CHSRBP\00_CADD\CCNM Option D\Sheets\TT-NP-TT-D1404.dgn
 1/22/2020 10:06:54 PM
 andrew.carson@tylin.com

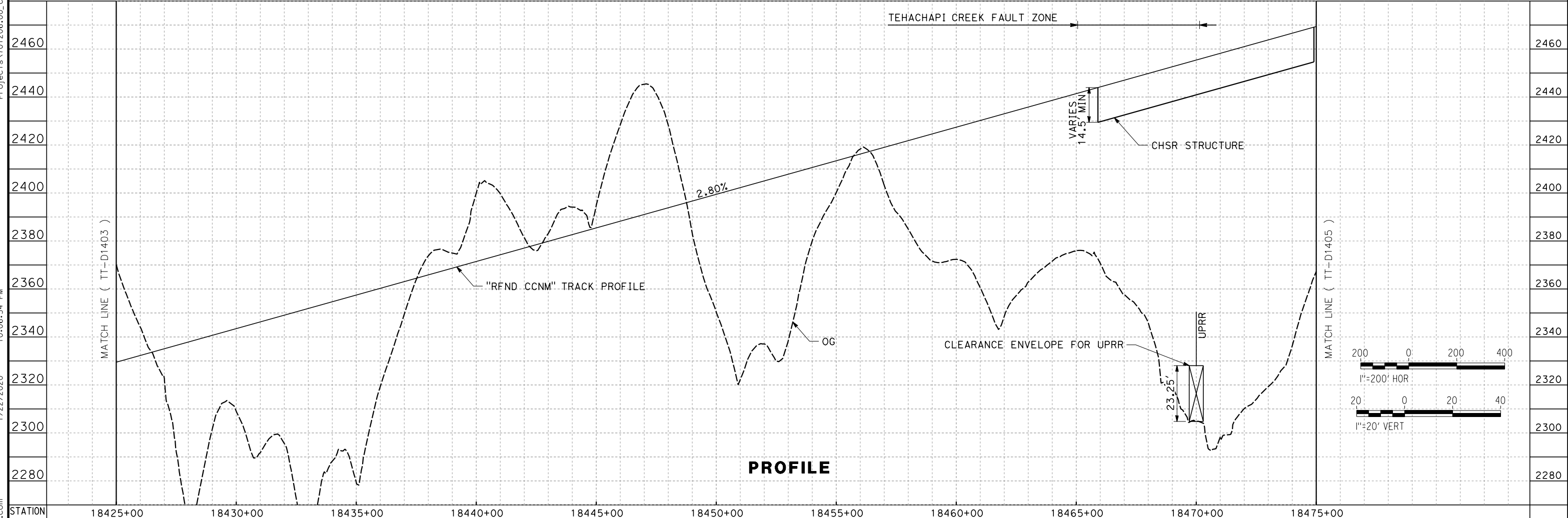
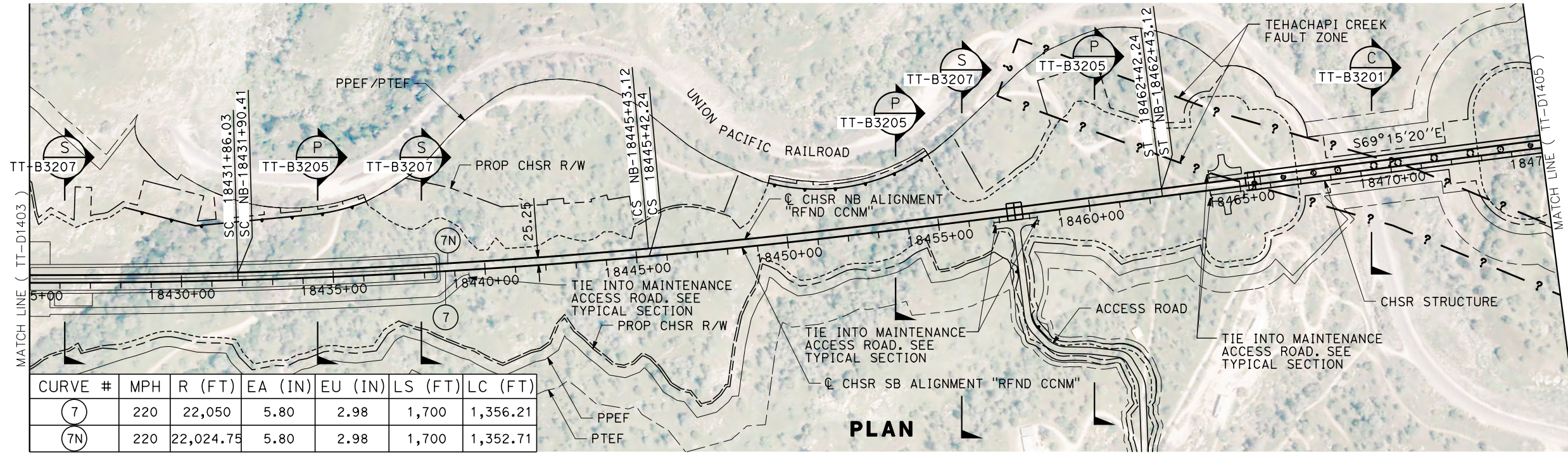

REV	DATE	BY	CHK	APP	DESCRIPTION

DESIGNED BY
A. CARSON
 DRAWN BY
A. CARSON
 CHECKED BY
S. LANDOLT
 IN CHARGE
G. CAMPBELL
 DATE
01/24/2020

**RECORD
 PEPD
 SUBMITTAL**

**NOT FOR
 CONSTRUCTION**



CALIFORNIA HIGH-SPEED RAIL PROJECT
BAKERSFIELD TO PALMDALE
 REFINED CCNM DESIGN OPTION
 TRACK GUIDEWAY
 STA 18425+00 TO 18475+00
 PLAN AND PROFILE

CONTRACT NO.
HSR13-44
 DRAWING NO.
TT-D1404
 SCALE
AS SHOWN
 SHEET NO.

Projects\701206_00_CHSRBP\00_CADD\CCNM Option D\Sheets\TT-NP-TT-D1406.dgn
 1/22/2020 10:08:42 PM andrew.carson@tylin.com

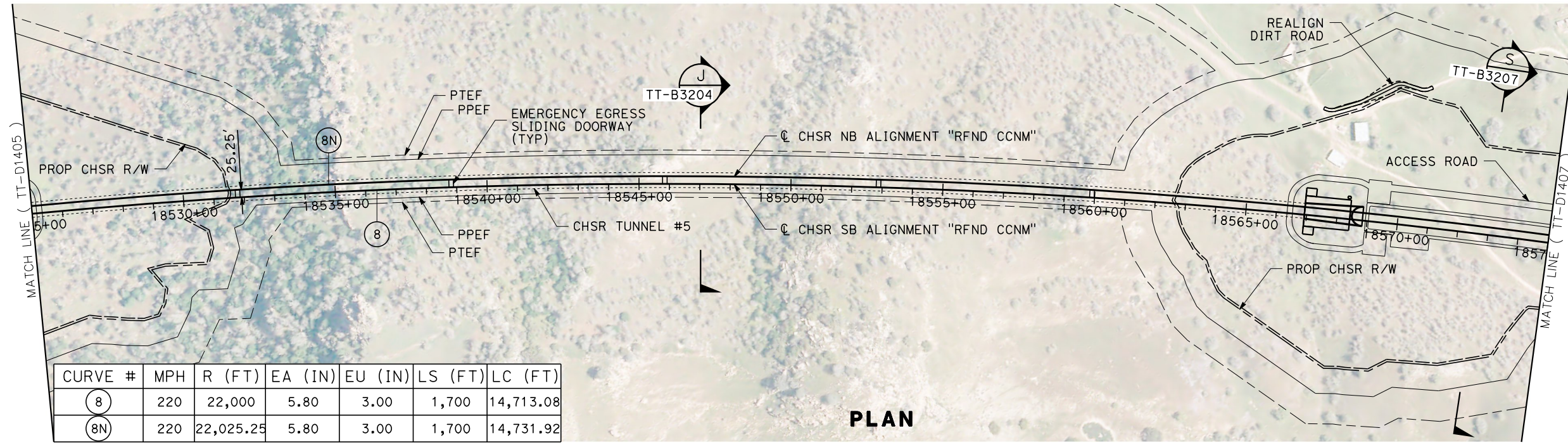

CURVE #	MPH	R (FT)	EA (IN)	EU (IN)	LS (FT)	LC (FT)
8	220	22,000	5.80	3.00	1,700	14,713.08
8N	220	22,025.25	5.80	3.00	1,700	14,731.92

PLAN

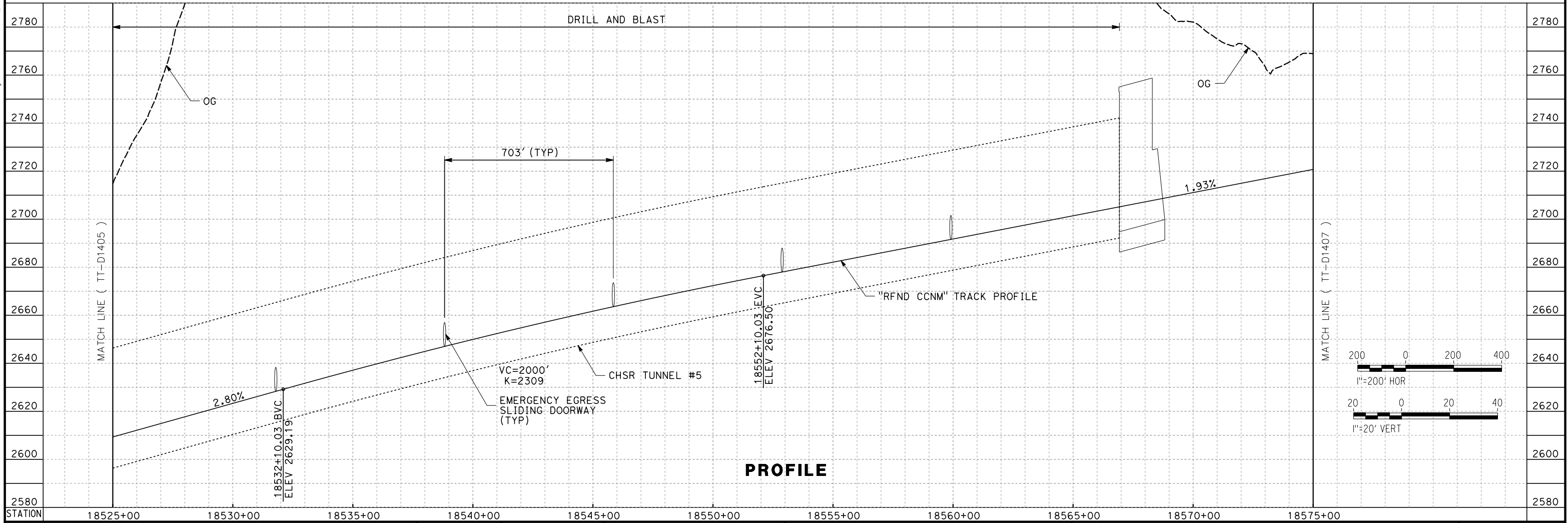

PROFILE

REV	DATE	BY	CHK	APP	DESCRIPTION

DESIGNED BY
A. CARSON
 DRAWN BY
A. CARSON
 CHECKED BY
S. LANDOLT
 IN CHARGE
G. CAMPBELL
 DATE
01/24/2020

**RECORD
 PEPD
 SUBMITTAL**

**NOT FOR
 CONSTRUCTION**



CALIFORNIA HIGH-SPEED RAIL PROJECT
BAKERSFIELD TO PALMDALE
 REFINED CCNM DESIGN OPTION
 TRACK GUIDEWAY
 STA 18525+00 TO 18575+00
 PLAN AND PROFILE

CONTRACT NO.
HSR13-44
 DRAWING NO.
TT-D1406
 SCALE
AS SHOWN
 SHEET NO.

1/22/2020 9:57:10 PM
 Projects\701206_00_CHSRBP\00_CADD\CCNM_Option D\Sheets\TT-NP-TT-D1407.dgn
 andrew.carson@tylin.com

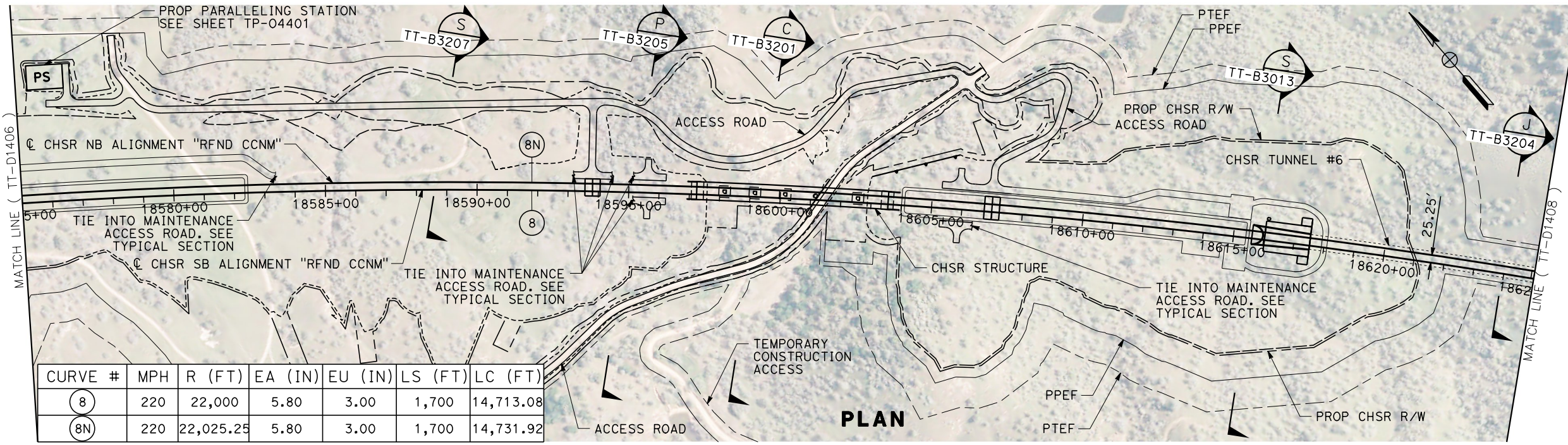

CURVE #	MPH	R (FT)	EA (IN)	EU (IN)	LS (FT)	LC (FT)
8	220	22,000	5.80	3.00	1,700	14,713.08
8N	220	22,025.25	5.80	3.00	1,700	14,731.92

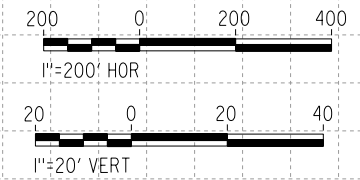
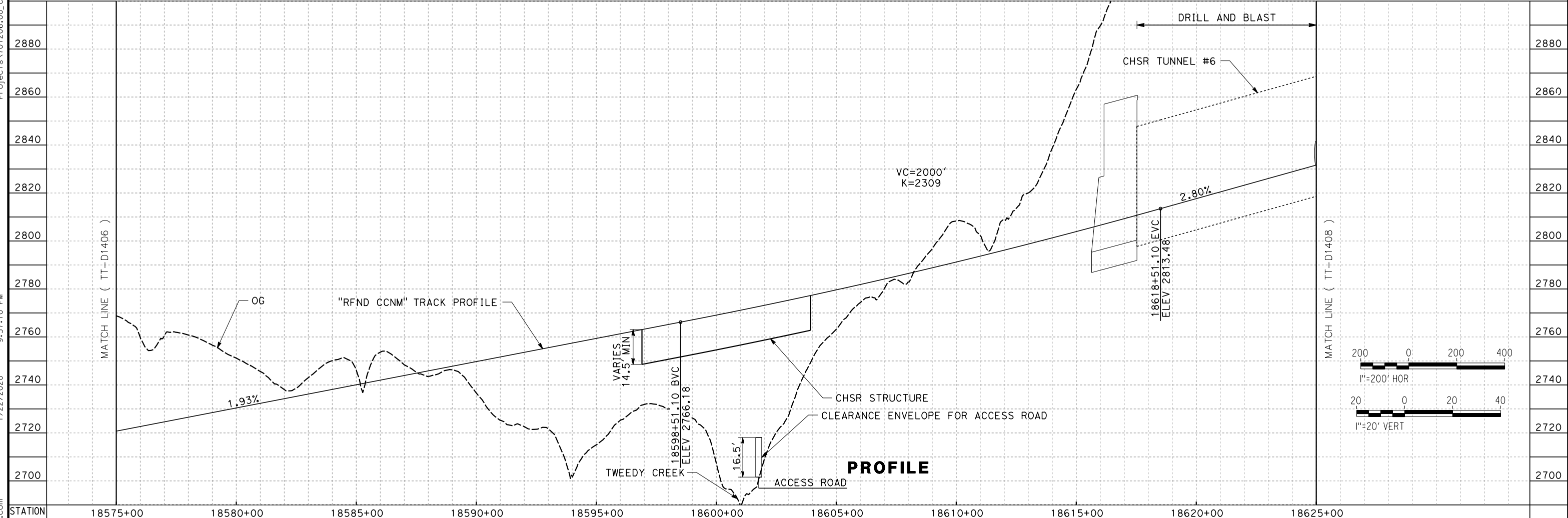

REV	DATE	BY	CHK	APP	DESCRIPTION

DESIGNED BY
A. CARSON
 DRAWN BY
A. CARSON
 CHECKED BY
S. LANDOLT
 IN CHARGE
G. CAMPBELL
 DATE
01/24/2020

**RECORD
 PECD
 SUBMITTAL**

**NOT FOR
 CONSTRUCTION**



CALIFORNIA HIGH-SPEED RAIL PROJECT
BAKERSFIELD TO PALMDALE
 REFINED CCNM DESIGN OPTION
 TRACK GUIDEWAY
 STA 18575+00 TO 18625+00
 PLAN AND PROFILE

CONTRACT NO.
HSR13-44
 DRAWING NO.
TT-D1407
 SCALE
AS SHOWN
 SHEET NO.

Projects\701206.00_CADD\CCNM Option D\Sheets\TT\BP-TT-D1408.dgn
1/22/2020 10:07:11 PM
andrew.carson@tylin.com

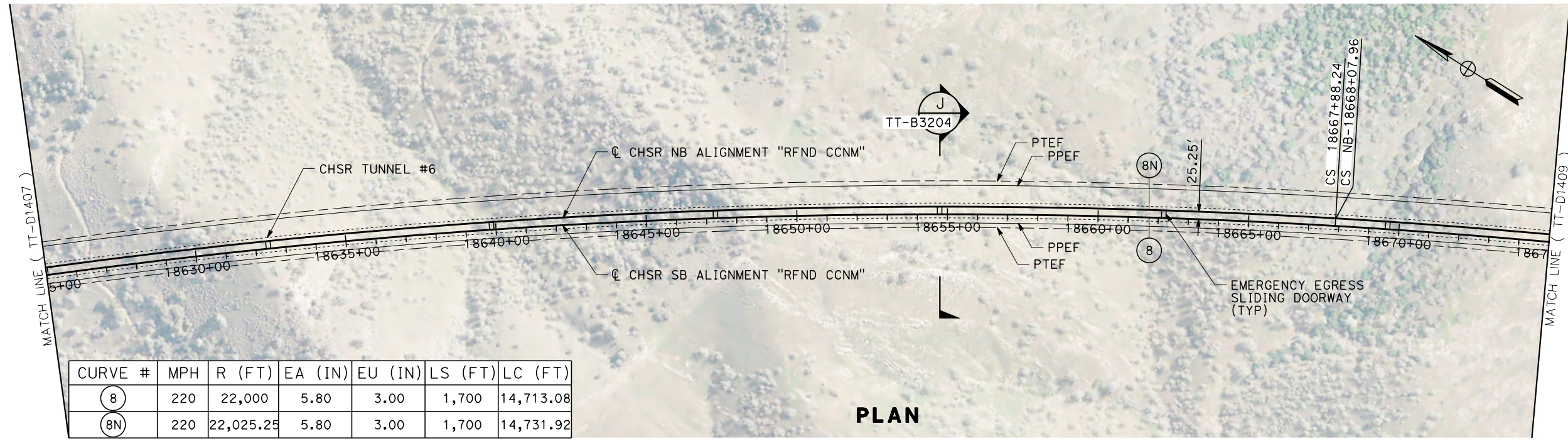

CURVE #	MPH	R (FT)	EA (IN)	EU (IN)	LS (FT)	LC (FT)
8	220	22,000	5.80	3.00	1,700	14,713.08
8N	220	22,025.25	5.80	3.00	1,700	14,731.92

PLAN

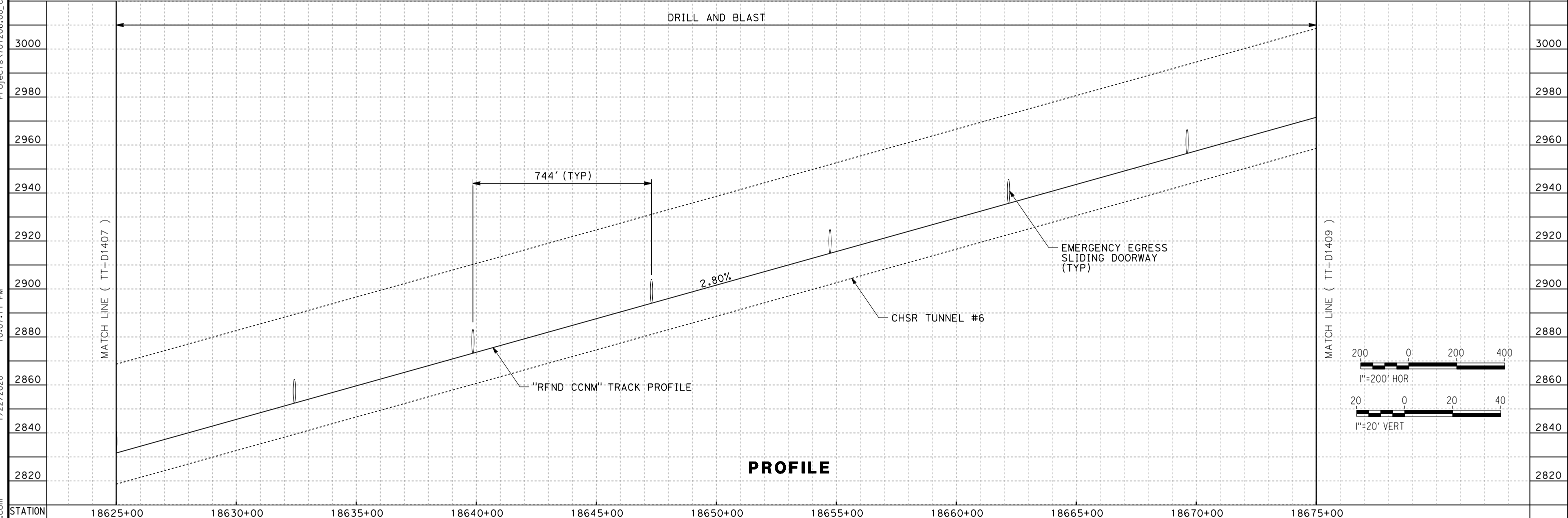

PROFILE

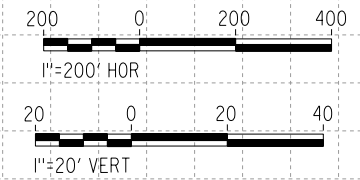

REV	DATE	BY	CHK	APP	DESCRIPTION

DESIGNED BY
A. CARSON
DRAWN BY
A. CARSON
CHECKED BY
S. LANDOLT
IN CHARGE
G. CAMPBELL
DATE
01/24/2020

**RECORD
PEPD
SUBMITTAL**

**NOT FOR
CONSTRUCTION**



**CALIFORNIA HIGH-SPEED RAIL PROJECT
BAKERSFIELD TO PALMDALE**
REFINED CCNM DESIGN OPTION
TRACK GUIDEWAY
STA 18625+00 TO 18675+00
PLAN AND PROFILE

CONTRACT NO.
HSR13-44
DRAWING NO.
TT-D1408
SCALE
AS SHOWN
SHEET NO.

Projects\701206_00_CHSRBP\00_CADD\CCNM Option D\Sheets\TT-NP-TT-D1409.dgn

1/22/2020 9:55:51 PM

andrew.carson@tylin.com

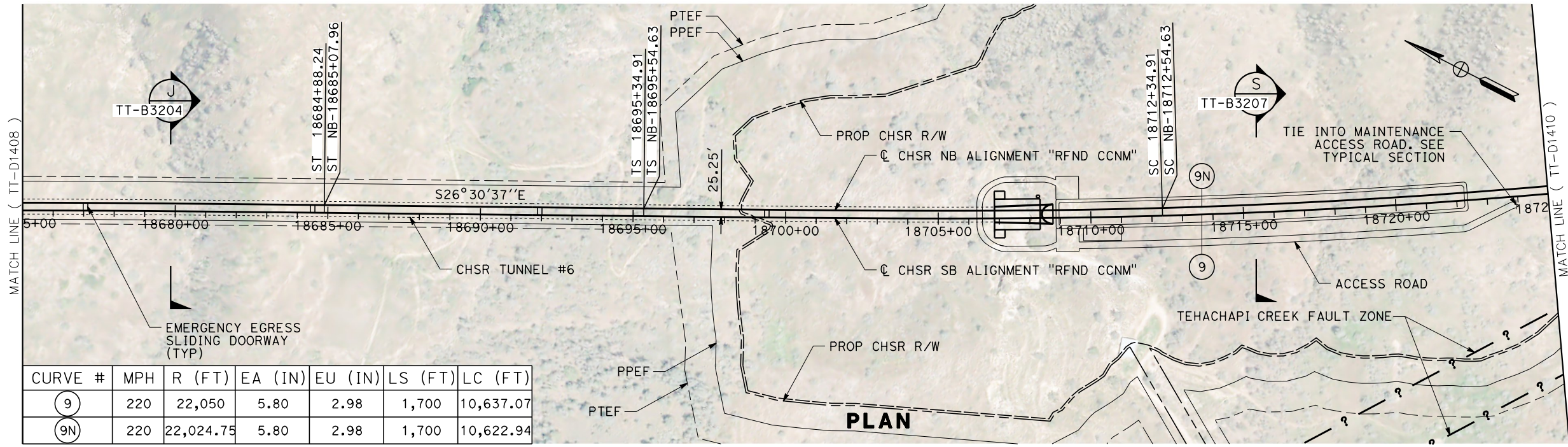

CURVE #	MPH	R (FT)	EA (IN)	EU (IN)	LS (FT)	LC (FT)
9	220	22,050	5.80	2.98	1,700	10,637.07
9N	220	22,024.75	5.80	2.98	1,700	10,622.94

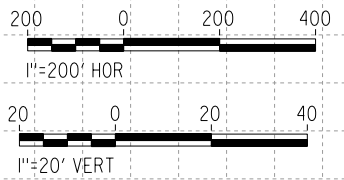
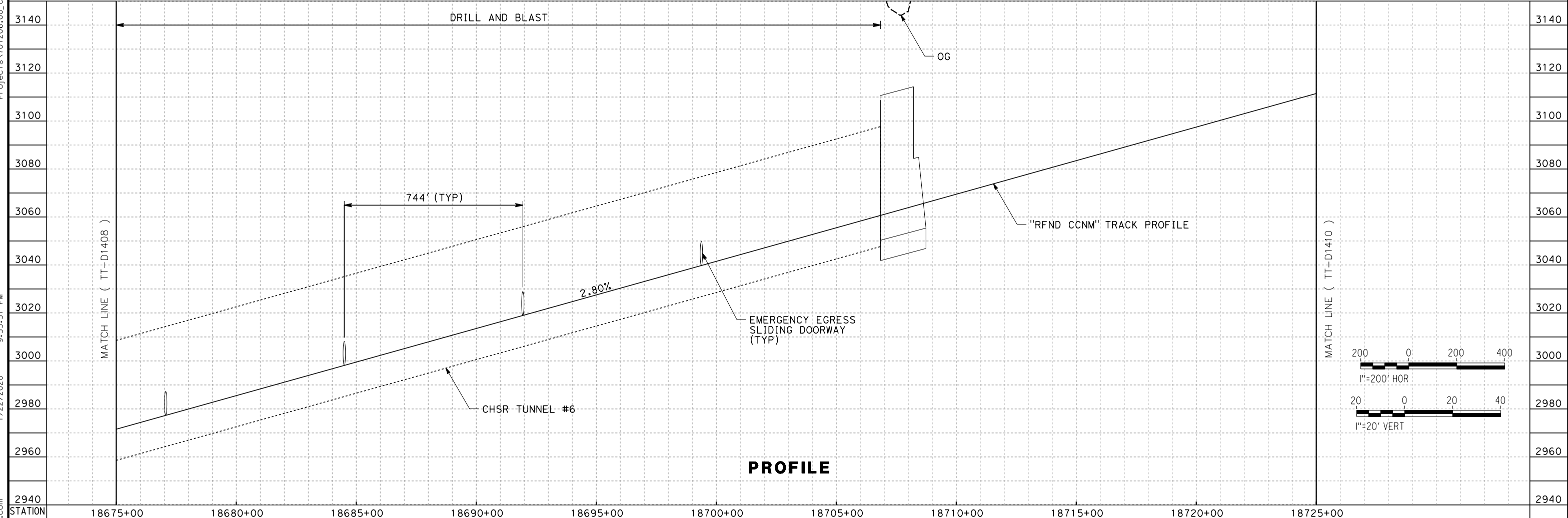

REV	DATE	BY	CHK	APP	DESCRIPTION

DESIGNED BY
A. CARSON
DRAWN BY
A. CARSON
CHECKED BY
S. LANDOLT
IN CHARGE
G. CAMPBELL
DATE
01/24/2020

**RECORD
PEPD
SUBMITTAL**

**NOT FOR
CONSTRUCTION**



**CALIFORNIA HIGH-SPEED RAIL PROJECT
BAKERSFIELD TO PALMDALE**
REFINED CCNM DESIGN OPTION
TRACK GUIDEWAY
STA 18675+00 TO 18725+00
PLAN AND PROFILE

CONTRACT NO.
HSR13-44
DRAWING NO.
TT-D1409
SCALE
AS SHOWN
SHEET NO.

Projects\701206_00_CHSRBP_00_CADD\CCNM Option D\Sheets\TT\BP-TT-D1410.dgn
 1/22/2020 10:07:31 PM andrew.carson@tylin.com

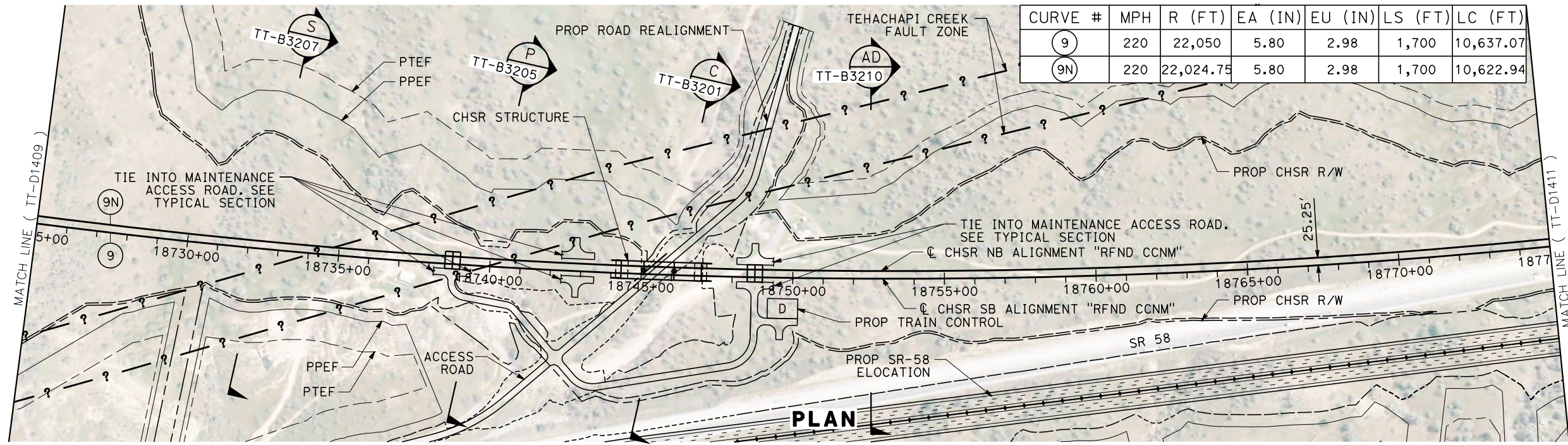

CURVE #	MPH	R (FT)	EA (IN)	EU (IN)	LS (FT)	LC (FT)
9	220	22,050	5.80	2.98	1,700	10,637.07
9N	220	22,024.75	5.80	2.98	1,700	10,622.94

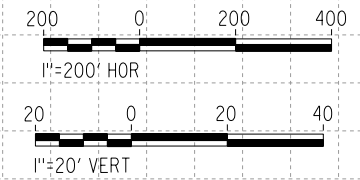
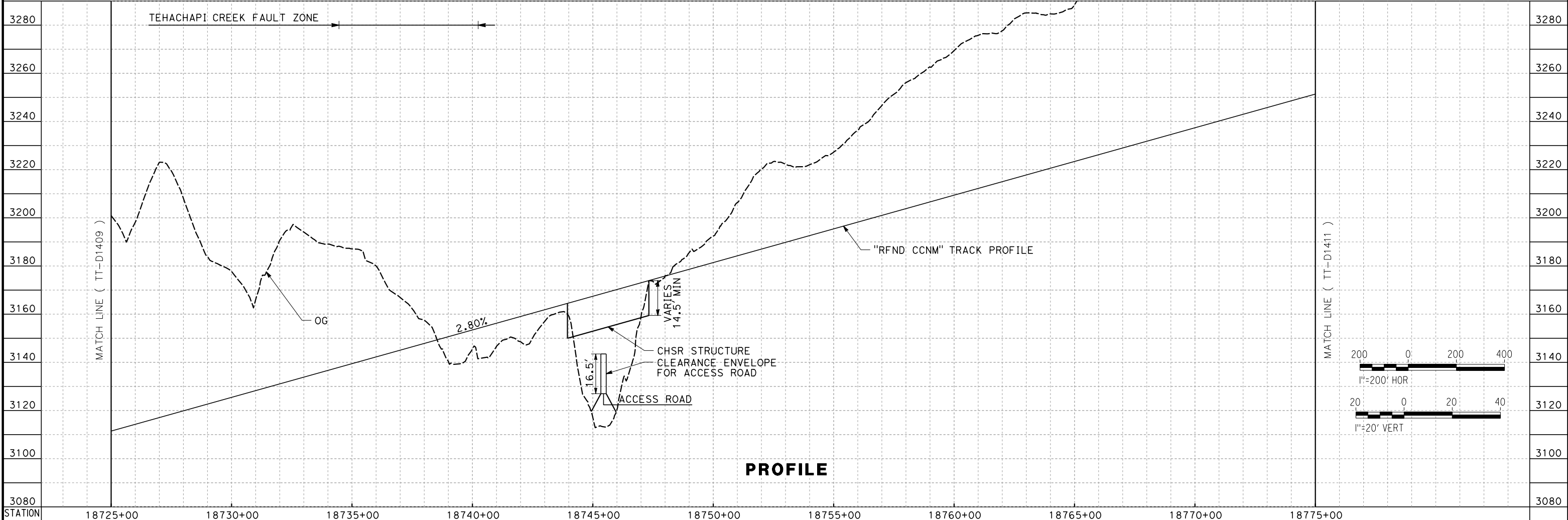
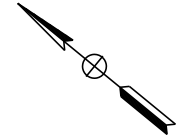

REV	DATE	BY	CHK	APP	DESCRIPTION

DESIGNED BY
A. CARSON
 DRAWN BY
A. CARSON
 CHECKED BY
S. LANDOLT
 IN CHARGE
G. CAMPBELL
 DATE
01/24/2020

**RECORD
 PEPD
 SUBMITTAL**

**NOT FOR
 CONSTRUCTION**

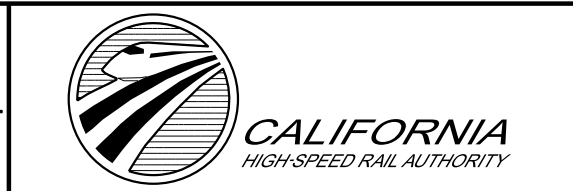

CALIFORNIA HIGH-SPEED RAIL PROJECT
BAKERSFIELD TO PALMDALE
 REFINED CCNM DESIGN OPTION
 TRACK GUIDEWAY
 STA 18725+00 TO 18775+00
 PLAN AND PROFILE

CONTRACT NO.
HSR13-44
 DRAWING NO.
TT-D1410
 SCALE
AS SHOWN
 SHEET NO.

CURVE #	MPH	R (FT)	EA (IN)	EU (IN)	LS (FT)	LC (FT)
9	220	22,050	5.80	2.98	1,700	10,637.07
9N	220	22,024.75	5.80	2.98	1,700	10,622.94

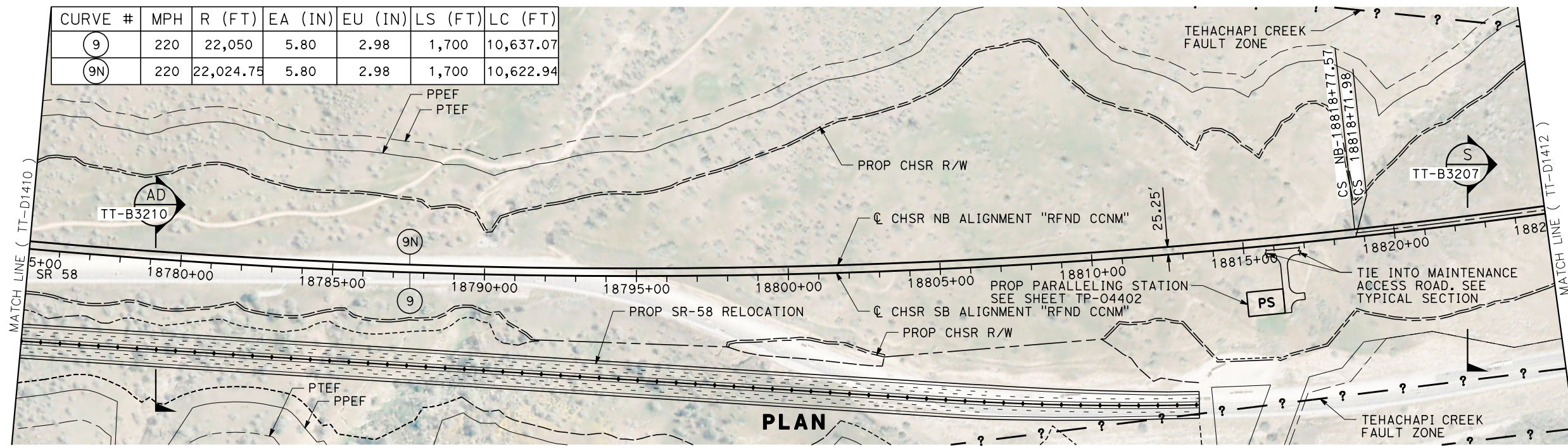

PLAN

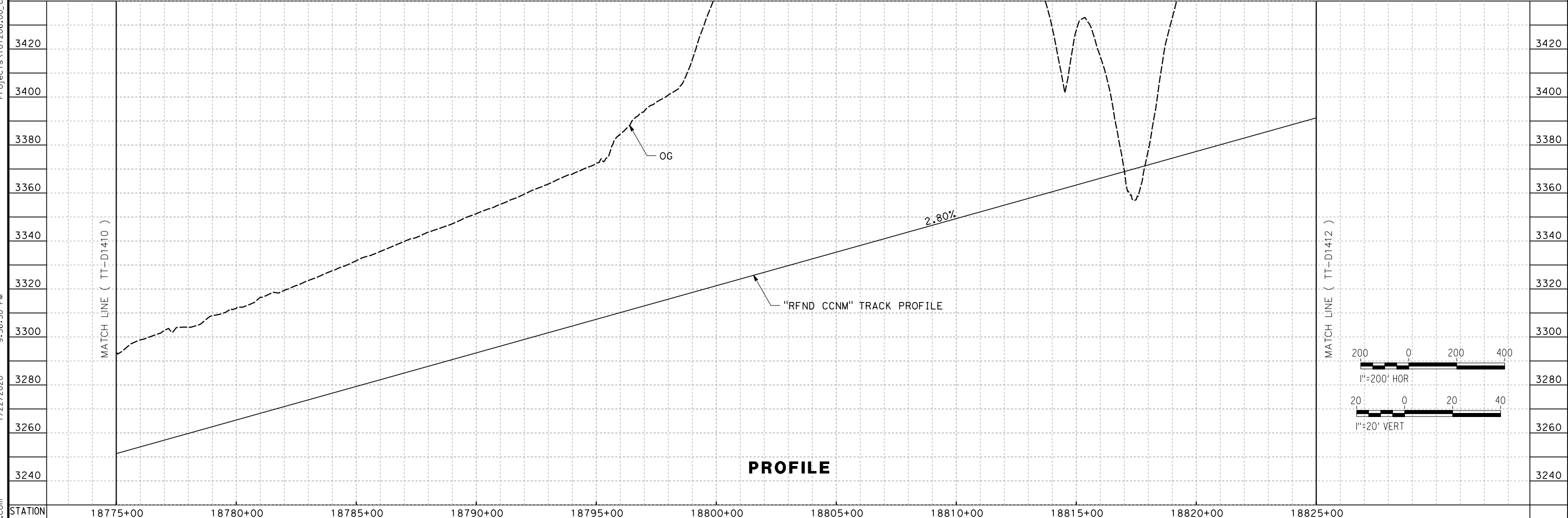

PROFILE

Projects\701206_00_CHSRBP\00_CADD\CCNM Option D\Sheets\TT\BP-TT-D1411.dgn
 1/22/2020 9:56:50 PM
 andrew.carson@tylin.com

REV	DATE	BY	CHK	APP	DESCRIPTION

DESIGNED BY
A. CARSON
 DRAWN BY
A. CARSON
 CHECKED BY
S. LANDOLT
 IN CHARGE
G. CAMPBELL
 DATE
01/24/2020

**RECORD
 PEPD
 SUBMITTAL**

**NOT FOR
 CONSTRUCTION**



CALIFORNIA HIGH-SPEED RAIL PROJECT
BAKERSFILED TO PALMDALE
 REFINED CCNM DESIGN OPTION
 TRACK GUIDEWAY
 STA 18775+00 TO 18825+00
 PLAN AND PROFILE

CONTRACT NO.
HSR13-44
 DRAWING NO.
TT-D1411
 SCALE
AS SHOWN
 SHEET NO.

1/22/2020 10:07:53 PM Projects\701206_00_CHSRBP_00_CADD\CCNM Option D\Sheets\TT\BP-TT-D1412.dgn andrew.carson@tylin.com

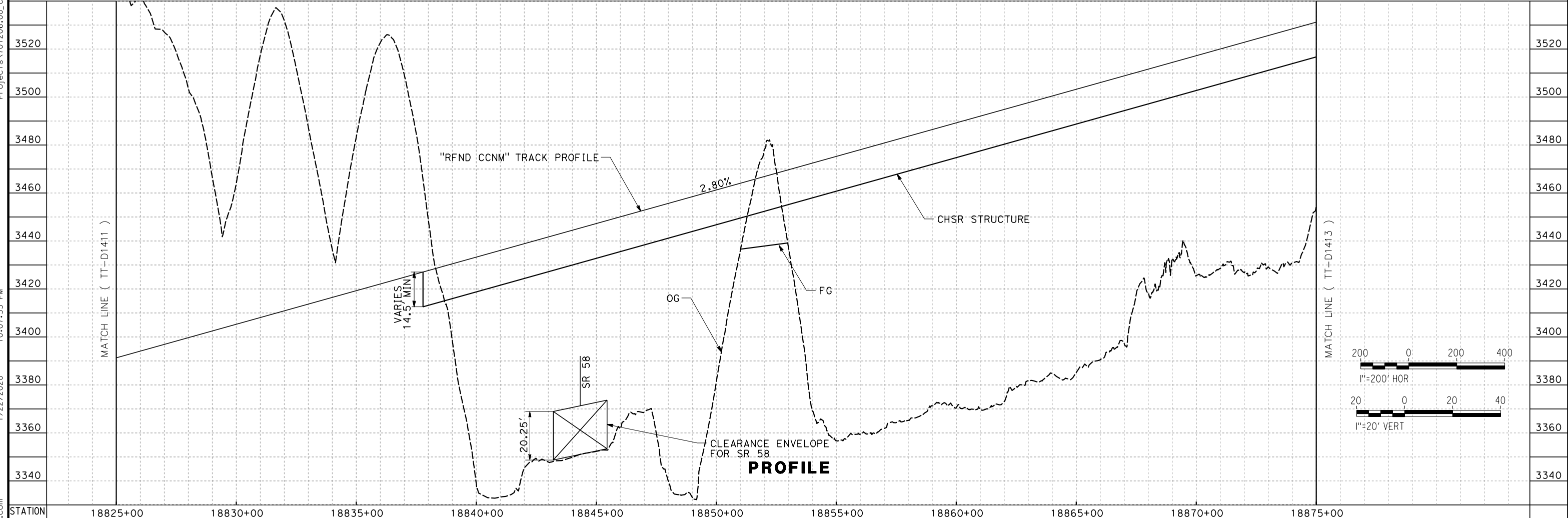
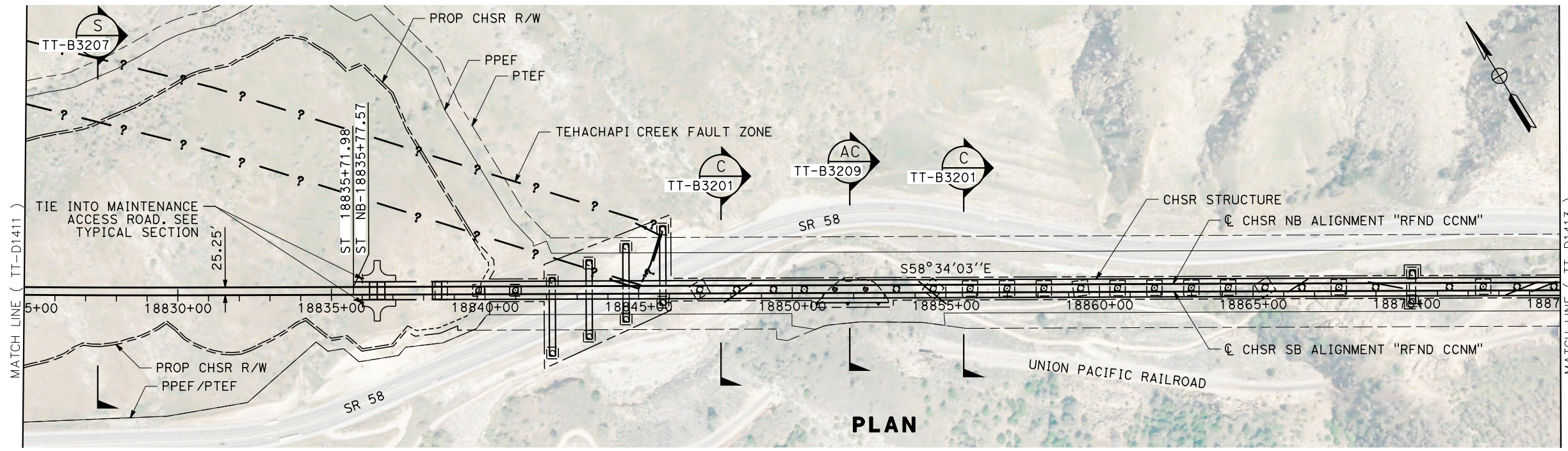

REV	DATE	BY	CHK	APP	DESCRIPTION

DESIGNED BY
A. CARSON
 DRAWN BY
A. CARSON
 CHECKED BY
S. LANDOLT
 IN CHARGE
G. CAMPBELL
 DATE
01/24/2020

**RECORD
 PECD
 SUBMITTAL**

**NOT FOR
 CONSTRUCTION**



CALIFORNIA HIGH-SPEED RAIL PROJECT
BAKERSFIELD TO PALMDALE
 REFINED CCNM DESIGN OPTION
 TRACK GUIDEWAY
 STA 18825+00 TO 18875+00
 PLAN AND PROFILE

CONTRACT NO.
HSR13-44
 DRAWING NO.
TT-D1412
 SCALE
AS SHOWN
 SHEET NO.

Projects\701206_00_CHSRBP\00_CADD\CCNM Option D\Sheets\TT-NB-TT-D1413.dgn
 1/22/2020 9:56:43 PM
 andrew.carson@tylin.com

CURVE #	MPH	R (FT)	EA (IN)	EU (IN)	LS (FT)	LC (FT)
10	250	45,000	3.00	2.56	1,450	2,909.51
10N	250	45,066	3.00	2.56	1,400	2,965.91

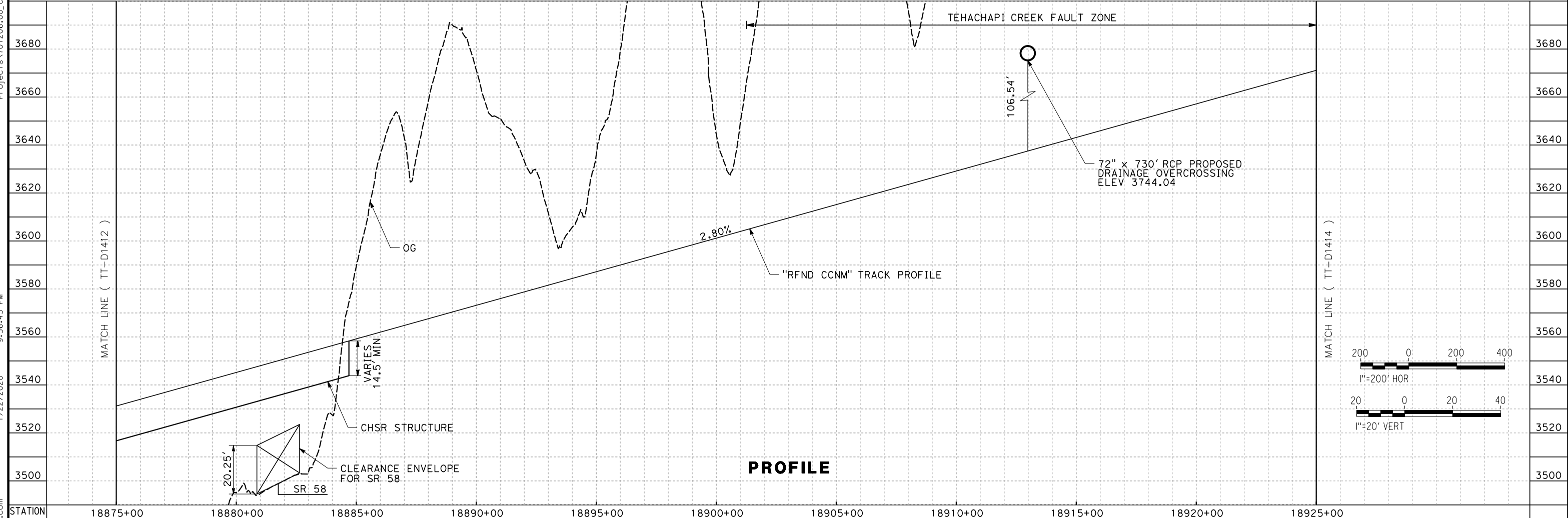
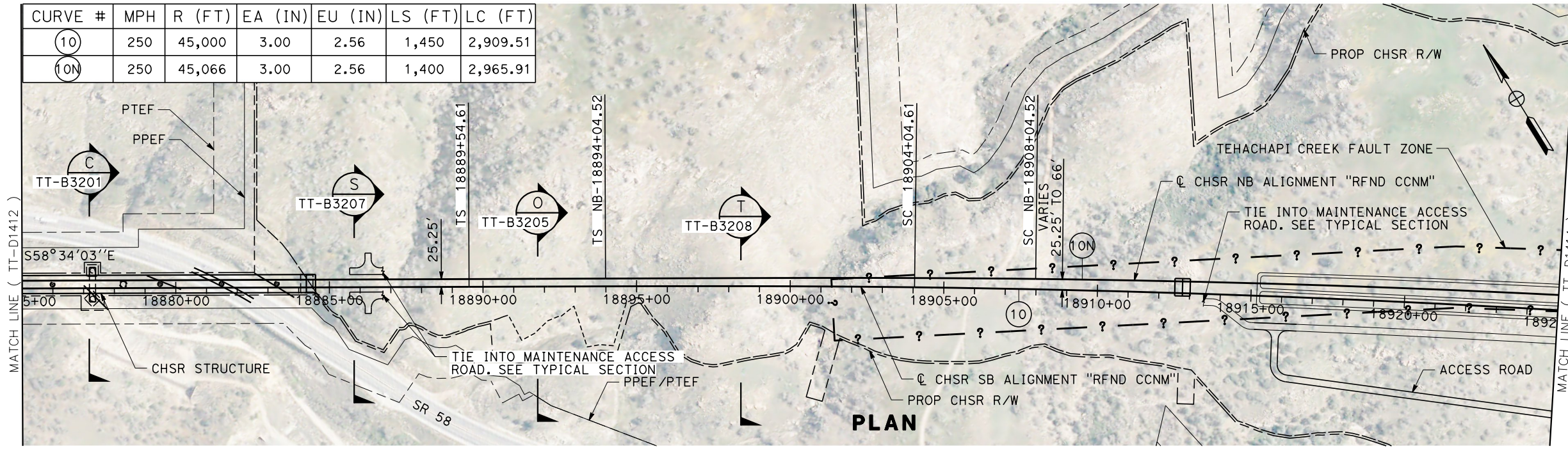

REV	DATE	BY	CHK	APP	DESCRIPTION

DESIGNED BY
A. CARSON
 DRAWN BY
A. CARSON
 CHECKED BY
S. LANDOLT
 IN CHARGE
G. CAMPBELL
 DATE
01/24/2020

**RECORD
 PEPD
 SUBMITTAL**

**NOT FOR
 CONSTRUCTION**



CALIFORNIA HIGH-SPEED RAIL PROJECT
BAKERSFIELD TO PALMDALE
 REFINED CCNM DESIGN OPTION
 TRACK GUIDEWAY
 STA 18875+00 TO 18925+00
 PLAN AND PROFILE

CONTRACT NO.
HSR13-44
 DRAWING NO.
TT-D1413
 SCALE
AS SHOWN
 SHEET NO.

Projects\701206_00_CHSRBP\00_CADD\CCNM Option D\Sheets\TT-NP-TT-D1414.dgn
 1/22/2020 10:09:45 PM andrew.carson@tylin.com

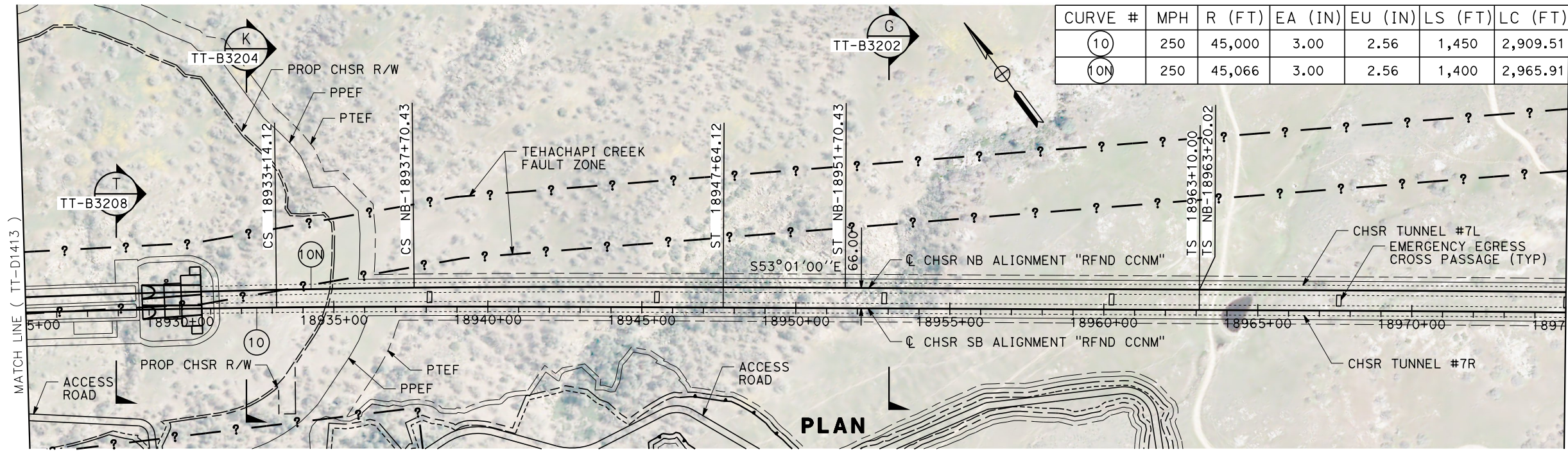

CURVE #	MPH	R (FT)	EA (IN)	EU (IN)	LS (FT)	LC (FT)
(10)	250	45,000	3.00	2.56	1,450	2,909.51
(10N)	250	45,066	3.00	2.56	1,400	2,965.91

PLAN

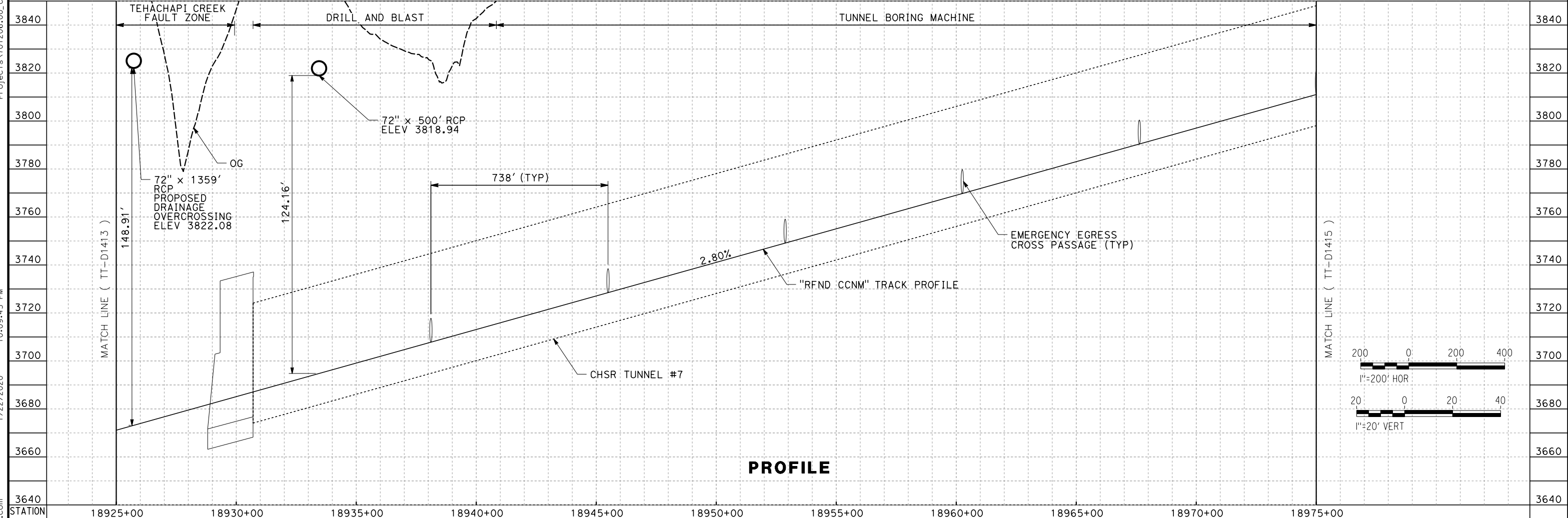

PROFILE

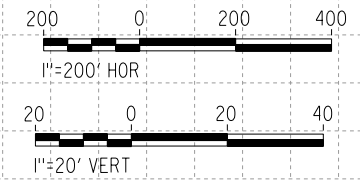

REV	DATE	BY	CHK	APP	DESCRIPTION

DESIGNED BY
A. CARSON
 DRAWN BY
A. CARSON
 CHECKED BY
S. LANDOLT
 IN CHARGE
G. CAMPBELL
 DATE
01/24/2020

**RECORD
PEPD
SUBMITTAL**

**NOT FOR
CONSTRUCTION**



CALIFORNIA HIGH-SPEED RAIL PROJECT
BAKERSFIELD TO PALMDALE
 REFINED CCNM DESIGN OPTION
 TRACK GUIDEWAY
 STA 18925+00 TO 18975+00
 PLAN AND PROFILE

CONTRACT NO.
HSR13-44
 DRAWING NO.
TT-D1414
 SCALE
AS SHOWN
 SHEET NO.

Projects\701206.00_CADD\CCNM Option D\Sheets\TT-NP-TT-D1415.dgn

1/22/2020 9:58:31 PM

andrew.carson@tylin.com

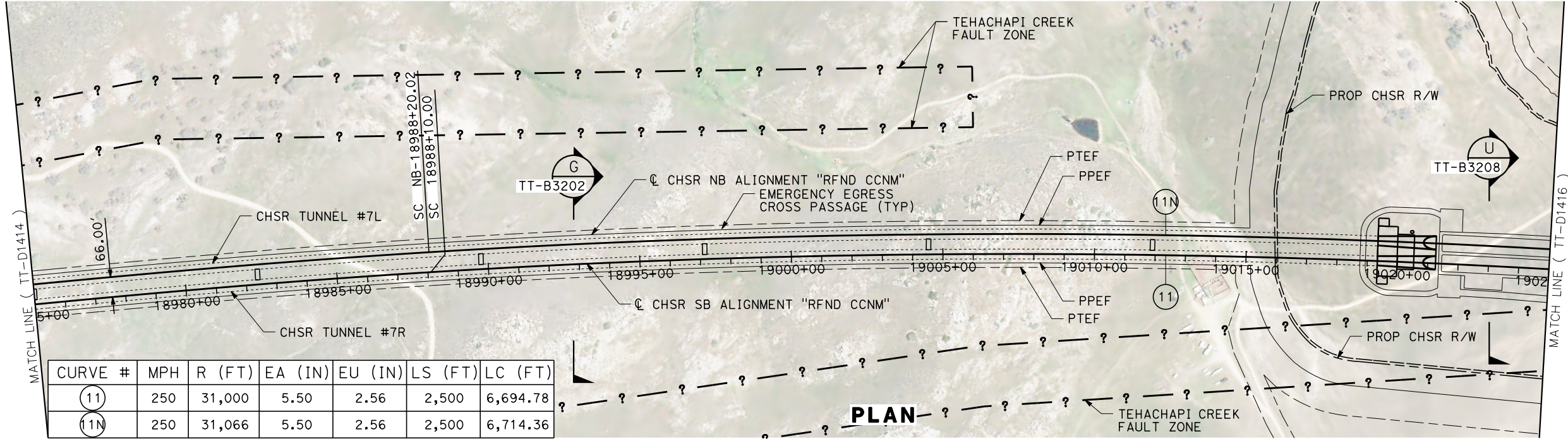

CURVE #	MPH	R (FT)	EA (IN)	EU (IN)	LS (FT)	LC (FT)
(11)	250	31,000	5.50	2.56	2,500	6,694.78
(11N)	250	31,066	5.50	2.56	2,500	6,714.36

PLAN

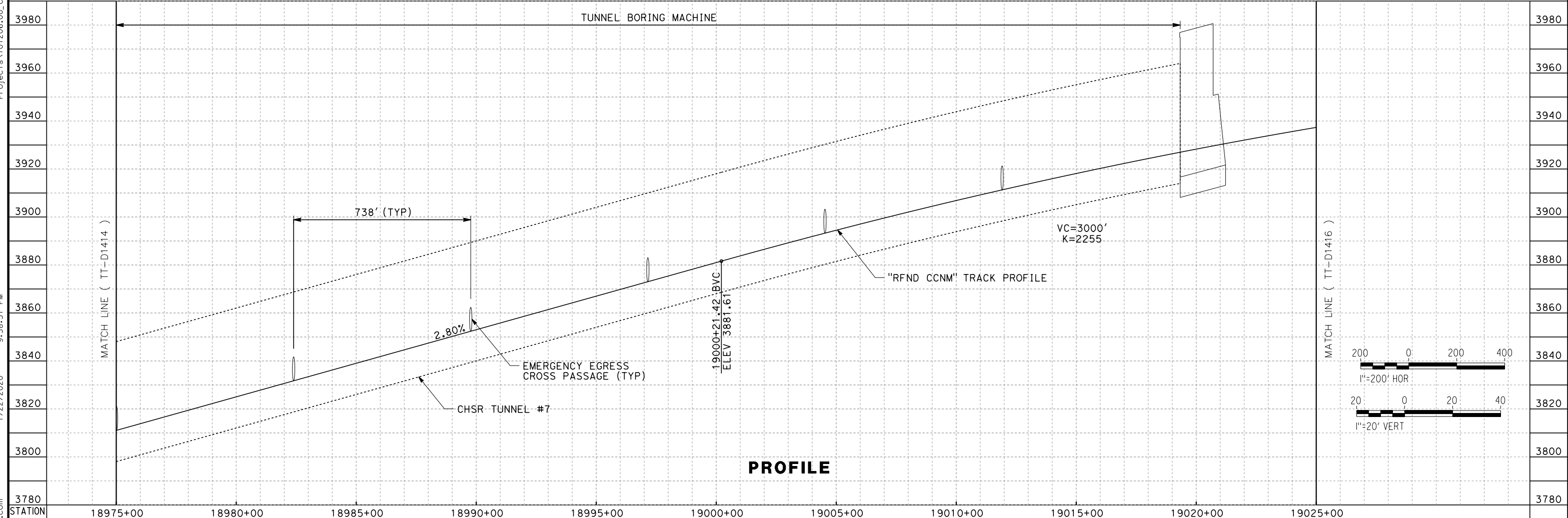

PROFILE

REV	DATE	BY	CHK	APP	DESCRIPTION

DESIGNED BY
A. CARSON
DRAWN BY
A. CARSON
CHECKED BY
S. LANDOLT
IN CHARGE
G. CAMPBELL
DATE
01/24/2020

**RECORD
PEPD
SUBMITTAL**

**NOT FOR
CONSTRUCTION**



CALIFORNIA HIGH-SPEED RAIL PROJECT
BAKERSFIELD TO PALMDALE
REFINED CCNM DESIGN OPTION
TRACK GUIDEWAY
STA 18975+00 TO 19025+00
PLAN AND PROFILE

CONTRACT NO.
HSR13-44
DRAWING NO.
TT-D1415
SCALE
AS SHOWN
SHEET NO.

Projects\701206_00_CHSRBP\00_CADD\CCNM Option D\Sheets\TT-NP-TT-D1416.dgn
 1/22/2020 10:08:15 PM andrew.carson@tylin.com

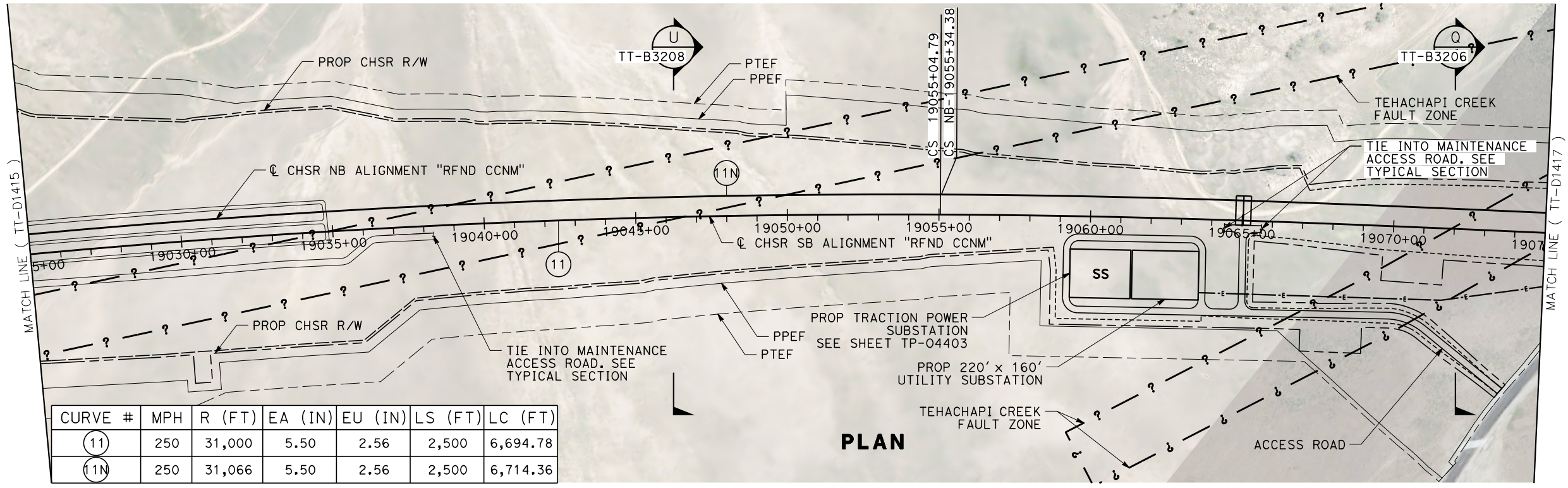

CURVE #	MPH	R (FT)	EA (IN)	EU (IN)	LS (FT)	LC (FT)
(11)	250	31,000	5.50	2.56	2,500	6,694.78
(11N)	250	31,066	5.50	2.56	2,500	6,714.36

PLAN

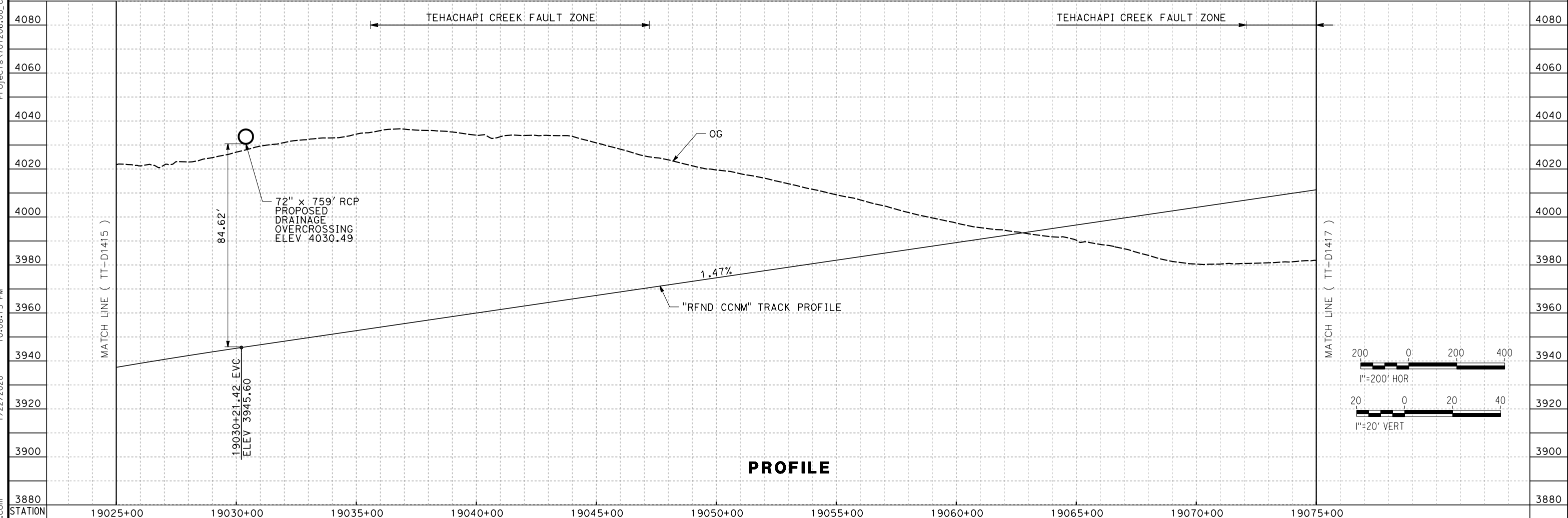

PROFILE

REV	DATE	BY	CHK	APP	DESCRIPTION

DESIGNED BY
A. CARSON
 DRAWN BY
A. CARSON
 CHECKED BY
S. LANDOLT
 IN CHARGE
G. CAMPBELL
 DATE
01/24/2020

**RECORD
 PEPD
 SUBMITTAL**

**NOT FOR
 CONSTRUCTION**



CALIFORNIA HIGH-SPEED RAIL PROJECT
BAKERSFIELD TO PALMDALE
 REFINED CCNM DESIGN OPTION
 TRACK GUIDEWAY
 STA 19025+00 TO 19075+00
 PLAN AND PROFILE

CONTRACT NO.
HSR13-44
 DRAWING NO.
TT-D1416
 SCALE
AS SHOWN
 SHEET NO.

Projects\701206_00_CHSRBP\00_CADD\CCNM Option D\Sheets\TT-NP-TT-D1417.dgn

1/22/2020 9:56:53 PM

andrew.carson@tylin.com

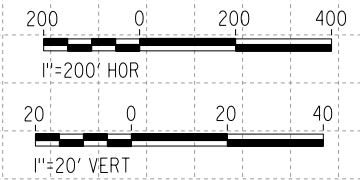
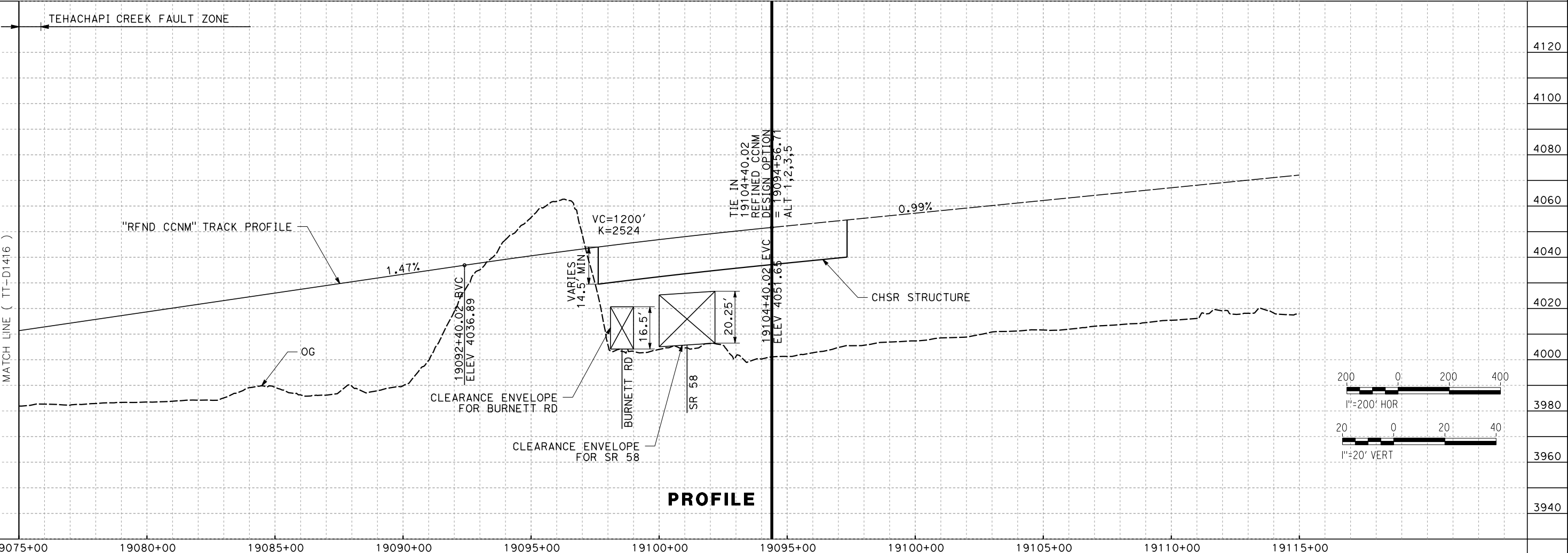
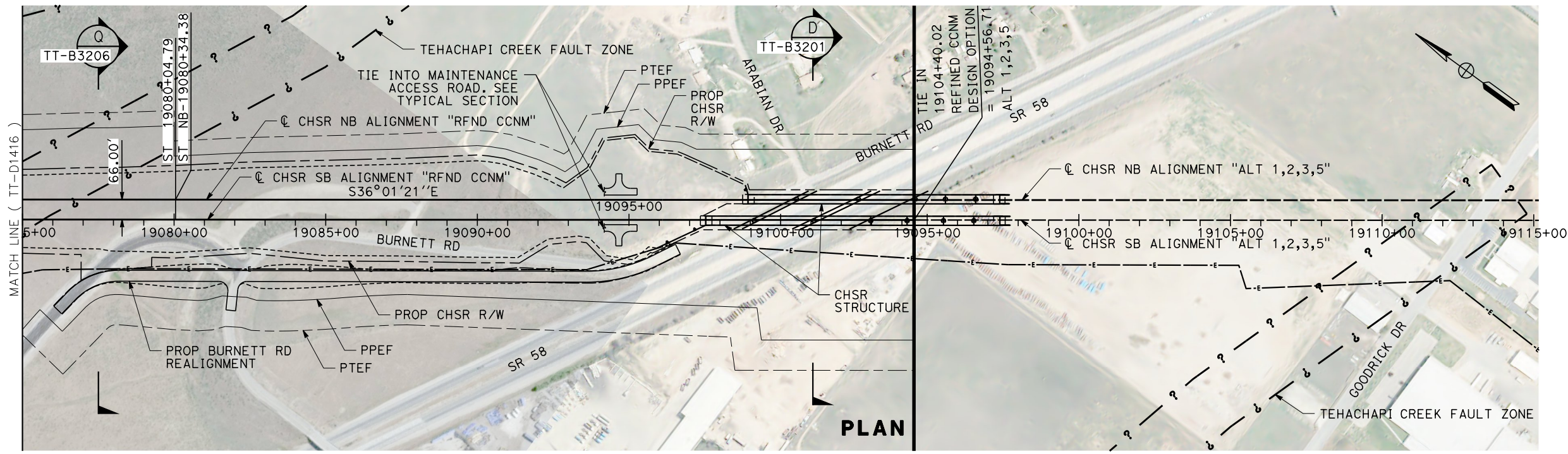

REV	DATE	BY	CHK	APP	DESCRIPTION

DESIGNED BY
A. CARSON
DRAWN BY
A. CARSON
CHECKED BY
S. LANDOLT
IN CHARGE
G. CAMPBELL
DATE
01/24/2020

**RECORD
PEPD
SUBMITTAL**

**NOT FOR
CONSTRUCTION**



**CALIFORNIA HIGH-SPEED RAIL PROJECT
BAKERSFIELD TO PALMDALE**
REFINED CCNM DESIGN OPTION
TRACK GUIDEWAY
STA 19075+00 TO 19115+00
PLAN AND PROFILE

CONTRACT NO.
HSR13-44
DRAWING NO.
TT-D1417
SCALE
AS SHOWN
SHEET NO.

LEGEND:

PLAN

SECTION NUMBER

DRAWING NUMBER

XX CURVE DATA (ALIGNMENTS, ROADWAYS)

XX LINE DATA (ALIGNMENTS, ROADWAYS)

NORTH ARROW

EXIST RIGHT OF WAY

LIMITS OF EXCAVATION (CUT)

LIMITS OF EMBANKMENT (FILL)

FAULT ZONE

EXIST RETAINING WALL

PROPOSED PERMANENT ENVIRONMENTAL FOOTPRINT

PROPOSED COLUMN/FOOTING

PROPOSED FENCE

PROPOSED RETAINING WALL

PROPOSED CONCRETE BARRIER

PROPOSED RIGHT OF WAY

PROPOSED TUNNEL

PROPOSED TEMPORARY ENVIRONMENTAL FOOTPRINT

SRS STANDALONE RADIO SITE

A AUTOMATIC TRAIN CONTROL SYSTEM SITE A

B AUTOMATIC TRAIN CONTROL SYSTEM SITE B

D AUTOMATIC TRAIN CONTROL SYSTEM SITE D

PLAN

E AUTOMATIC TRAIN CONTROL SYSTEM SITE E

TRACK CROSSING PANEL

SS SUBSTATION

SW SWITCHING STATION

PS PARALLELING STATION

UTILITIES

w EXISTING AQUEDUCT

e EXISTING ELECTRICAL TRANSMISSION

gs EXISTING GAS LINE

PROFILE

ORIGINAL GROUND

PROPOSED GRADE

GENERAL NOTES

1. SB TRACK ALIGNMENT STATIONING IS PROVIDED.
2. PROPOSED PERMANENT ENVIRONMENTAL FOOTPRINT (PPEF) SHOWN IS LIMIT OF PERMANENT GROUND DISTURBANCE ASSOCIATED WITH THE PROJECT.
3. PROPOSED TEMPORARY ENVIRONMENTAL FOOTPRINT (PTEF) SHOWN IS LIMIT OF TEMPORARY GROUND DISTURBANCE ASSOCIATED WITH THE PROJECT.
4. ALL UTILITIES ARE TO BE FIELD VERIFIED PRIOR TO CONSTRUCTION.
5. FOR DETAILED STRUCTURE DEPTH INFORMATION SEE STRUCTURAL PLAN SET.

Projects\701206.00_CHSRBP\00_CADD\CCNM_Option_D\Sheets\CV\BP-CV-R0101
 1/22/2020 11:44:28 PM
 andrew.carson@tylin.com

REV	DATE	BY	CHK	APP	DESCRIPTION

DESIGNED BY
A. CARSON
 DRAWN BY
A. CARSON
 CHECKED BY
D. HOLMAN
 IN CHARGE
G. CAMPBELL
 DATE
01/24/2020

**RECORD
 PEPD
 SUBMITTAL**

**NOT FOR
 CONSTRUCTION**

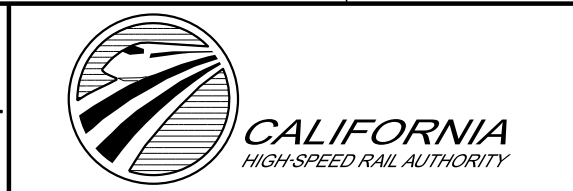

CALIFORNIA HIGH-SPEED RAIL PROJECT
BAKERSFIELD TO PALMDALE
 REFINED CCNM DESIGN OPTION
 ROADWAY GENERAL
 SYMBOLS, LEGEND, AND GENERAL NOTES

CONTRACT NO.
HSR13-44
 DRAWING NO.
CV-R0101
 SCALE
NO SCALE
 SHEET NO.

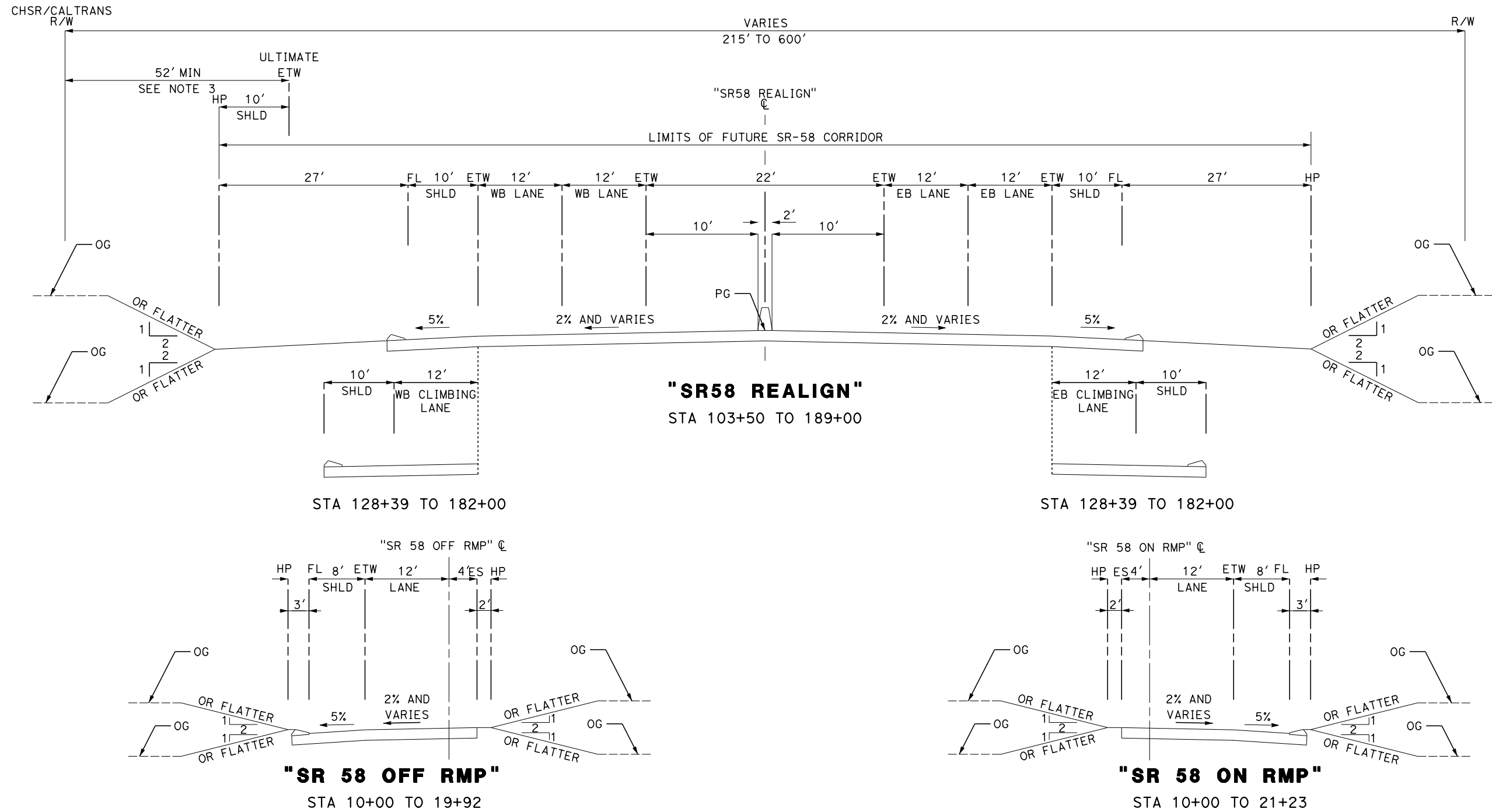

NOTE:

1. AUXILIARY LANES ARE PROVIDED FROM STA 118+39 TO 128+39
2. TRUCK CLIMBING LANES ARE PROVIDED FROM STA 128+39 TO 182+00
3. A MINIMUM HORIZONTAL CLEARANCE OF 52 FEET IS PROVIDED FROM THE PLANNED ULTIMATE EDGE OF THE TRAVEL WAY (ETW) TO THE HIGH SPEED RAIL CORRIDOR IN ACCORDANCE WITH THE CALTRANS HIGHWAY DESIGN MANUAL.

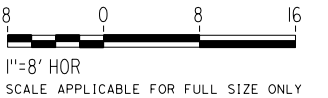

Projects\701206.00_CHSRBP\00_CADD\CCNM_Option D\Sheets\CV\BP-CV-R0102
 10:47:44 PM
 1/23/2020
 andrew.carson@tylin.com

REV	DATE	BY	CHK	APP	DESCRIPTION

DESIGNED BY
A. CARSON
 DRAWN BY
A. CARSON
 CHECKED BY
D. HOLMAN
 IN CHARGE
G. CAMPBELL
 DATE
01/24/2020

**RECORD
 PECD
 SUBMITTAL**

**NOT FOR
 CONSTRUCTION**



CALIFORNIA HIGH-SPEED RAIL PROJECT
BAKERSFIELD TO PALMDALE
 REFINED CCNM DESIGN OPTION
 ROADWAY GENERAL
 TYPICAL SECTIONS
 SHEET 1 OF 2

CONTRACT NO.
HSR13-44
 DRAWING NO.
CV-R0102
 SCALE
AS SHOWN
 SHEET NO.

Projects\701206_00_CHSRBP_V00_CADD\CCNM_Option_D\Sheets\CV\BP-CV-R0104

11:56:41 PM

andrew.carson@tylin.com
1/22/2020

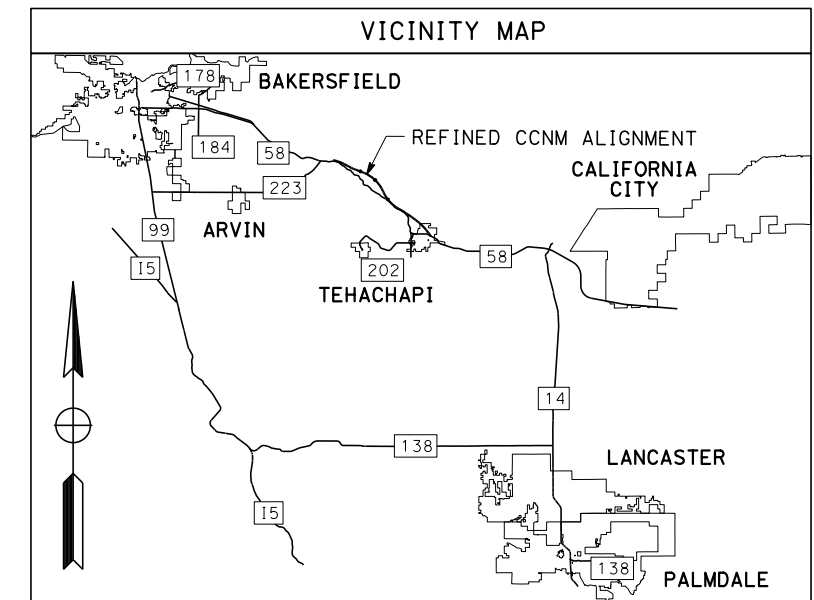

REFINED CCNM DESIGN OPTION

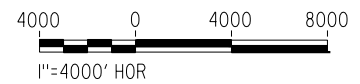
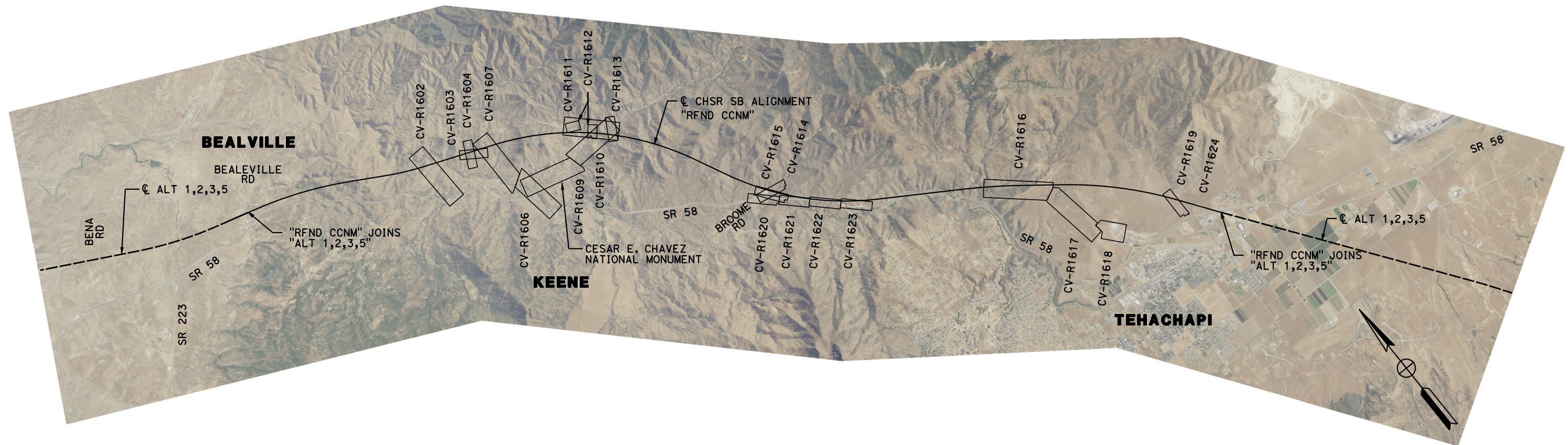

REV	DATE	BY	CHK	APP	DESCRIPTION

DESIGNED BY
A. CARSON
DRAWN BY
A. CARSON
CHECKED BY
D. HOLMAN
IN CHARGE
G. CAMPBELL
DATE
01/24/2020

**RECORD
PEPD
SUBMITTAL**

**NOT FOR
CONSTRUCTION**

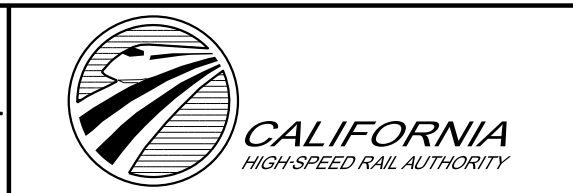

CALIFORNIA HIGH-SPEED RAIL PROJECT
BAKERSFIELD TO PALMDALE
REFINED CCNM DESIGN OPTION
ROADWAY GENERAL
KEY MAP

CONTRACT NO.
HSR13-44
DRAWING NO.
CV-R0104
SCALE
AS SHOWN
SHEET NO.

Projects\701206.00_CHSRBP\00_CADD\CCNM_Option_D\Sheets\CV\BP-CV-R1601

andrew.carson@tylin.com 1/22/2020 11:47:25 PM

LINE DATA		
No.	BEARING	DISTANCE
1	N 69°54'18" E	14.38'
2	N 20°05'42" W	182.95'
3	N 1°44'54" E	5.64'
4	N 58°06'28" W	112.37'
5	N 25°47'20" W	106.93'
6	N 78°46'55" W	56.38'
7	N 8°05'54" E	85.37'
8	N 11°18'17" W	85.49'
9	N 11°34'51" E	156.55'
10	N 23°36'13" W	302.21'
11	N 22°49'25" E	65.03'
12	N 7°20'56" W	69.72'
13	N 46°37'35" E	110.84'
14	N 72°26'18" E	75.10'
15	N 29°40'44" E	116.62'
16	N 43°55'31" E	69.11'
17	N 25°51'20" E	226.64'
18	N 2°43'50" W	54.10'
19	N 55°28'02" W	90.55'
20	N 60°48'26" W	73.70'
21	N 15°35'54" W	41.99'
22	N 20°49'06" E	302.52'

CURVE DATA				
No.	R	Δ	T	L
1	100.00'	90°00'00"	100.00'	157.08'
2	100.00'	21°50'36"	19.30'	38.12'
3	45.00'	59°51'22"	25.91'	47.01'
4	100.00'	32°19'09"	28.98'	56.41'
5	70.00'	52°59'35"	34.90'	64.74'
6	70.00'	86°52'49"	66.29'	106.14'
7	45.00'	19°24'11"	7.69'	15.24'
8	100.00'	22°53'07"	20.24'	39.94'
9	300.00'	35°11'04"	95.12'	184.23'
10	100.00'	46°25'39"	42.89'	81.03'
11	75.00'	30°10'21"	20.22'	39.50'
12	75.00'	53°58'30"	38.19'	70.65'
13	75.00'	25°48'44"	17.19'	33.79'
14	75.00'	42°45'35"	29.36'	55.97'
15	75.00'	14°14'47"	9.37'	18.65'
16	75.00'	18°04'11"	11.93'	23.65'
17	100.00'	28°35'10"	25.48'	49.89'
18	50.00'	52°44'11"	24.79'	46.02'
19	100.00'	5°20'25"	4.66'	9.32'
20	100.00'	45°12'32"	41.64'	78.90'
21	100.00'	36°25'00"	32.89'	63.56'

REV	DATE	BY	CHK	APP	DESCRIPTION

DESIGNED BY
A. CARSON
DRAWN BY
A. CARSON
CHECKED BY
D. HOLMAN
IN CHARGE
G. CAMPBELL
DATE
01/24/2020

**RECORD
PEPD
SUBMITTAL**

**NOT FOR
CONSTRUCTION**



**CALIFORNIA HIGH-SPEED RAIL PROJECT
BAKERSFIELD TO PALMDALE**
REFINED CCNM DESIGN OPTION
ROADWAY
ACCESS ROAD "18457"
HORIZONTAL ALIGNMENT DATA TABLE

CONTRACT NO.
HSR13-44
DRAWING NO.
CV-R1601
SCALE
NO SCALE
SHEET NO.

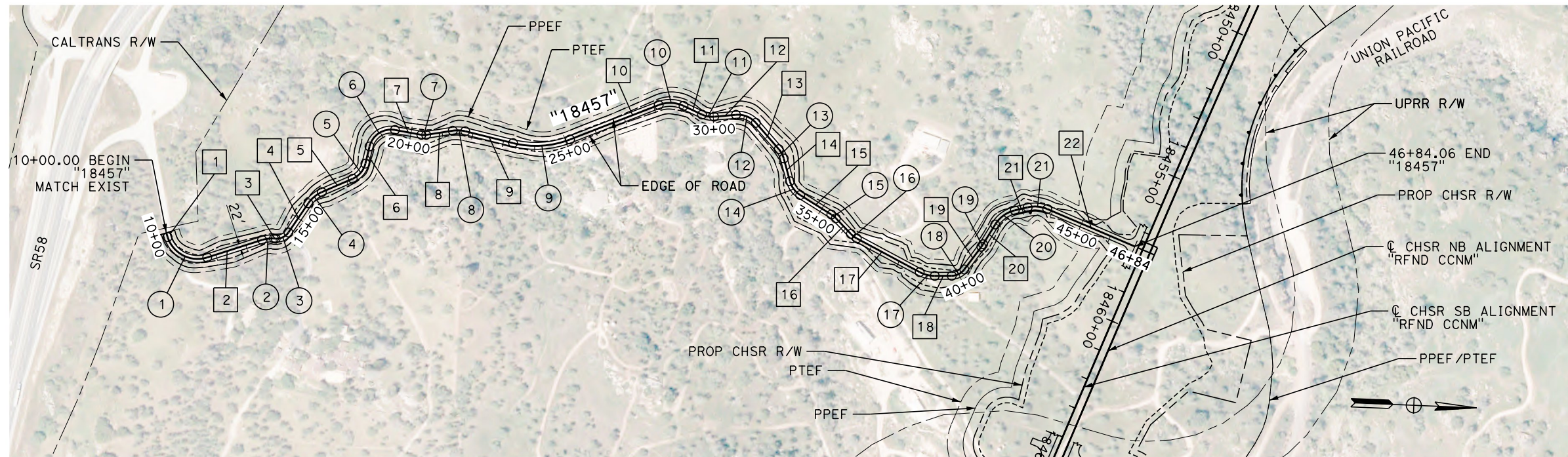

PLAN

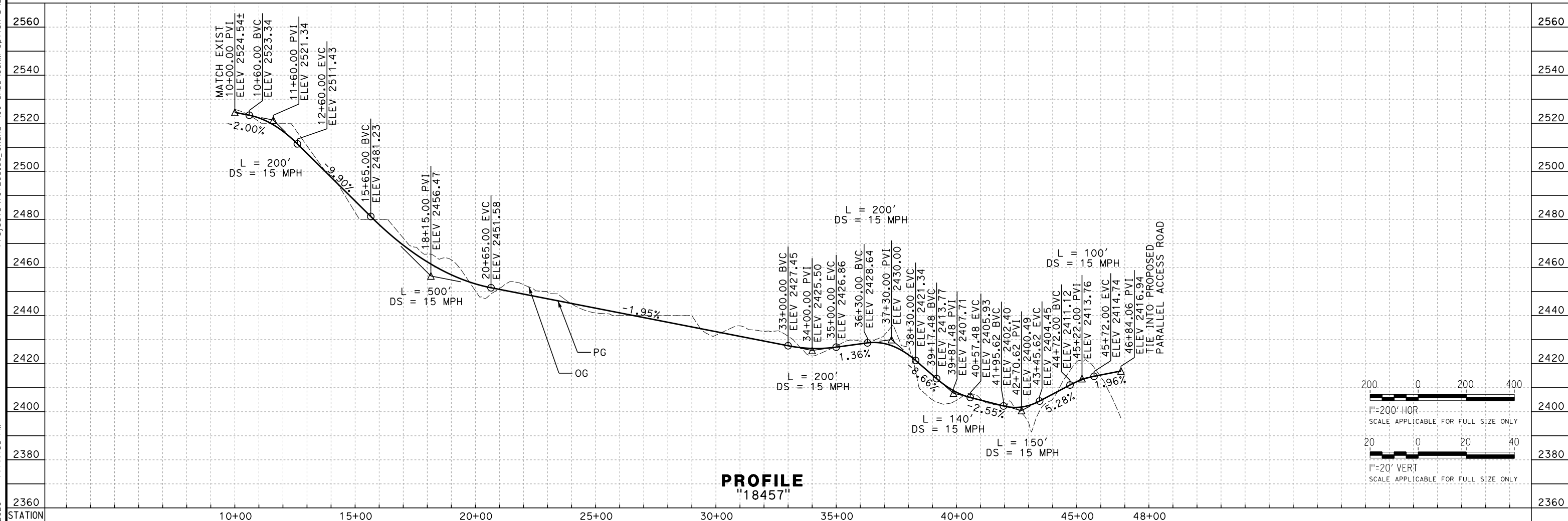

PROFILE
"18457"

Projects\701206.00_CHSRBP\00_CADD\CCNM_Option D\Sheets\CV\BP-CV-R1602
 1/22/2020 11:47:38 PM
 andrew.carson@tylin.com

REV	DATE	BY	CHK	APP	DESCRIPTION

DESIGNED BY
A. CARSON
 DRAWN BY
A. CARSON
 CHECKED BY
D. HOLMAN
 IN CHARGE
G. CAMPBELL
 DATE
01/24/2020

**RECORD
PEPD
SUBMITTAL**

**NOT FOR
CONSTRUCTION**



CALIFORNIA HIGH-SPEED RAIL PROJECT
BAKERSFIELD TO PALMDALE
 REFINED CCNM DESIGN OPTION
 ROADWAY
 ACCESS ROAD "18457"
 PLAN AND PROFILE

CONTRACT NO.
HSR13-44
 DRAWING NO.
CV-R1602
 SCALE
AS SHOWN
 SHEET NO.

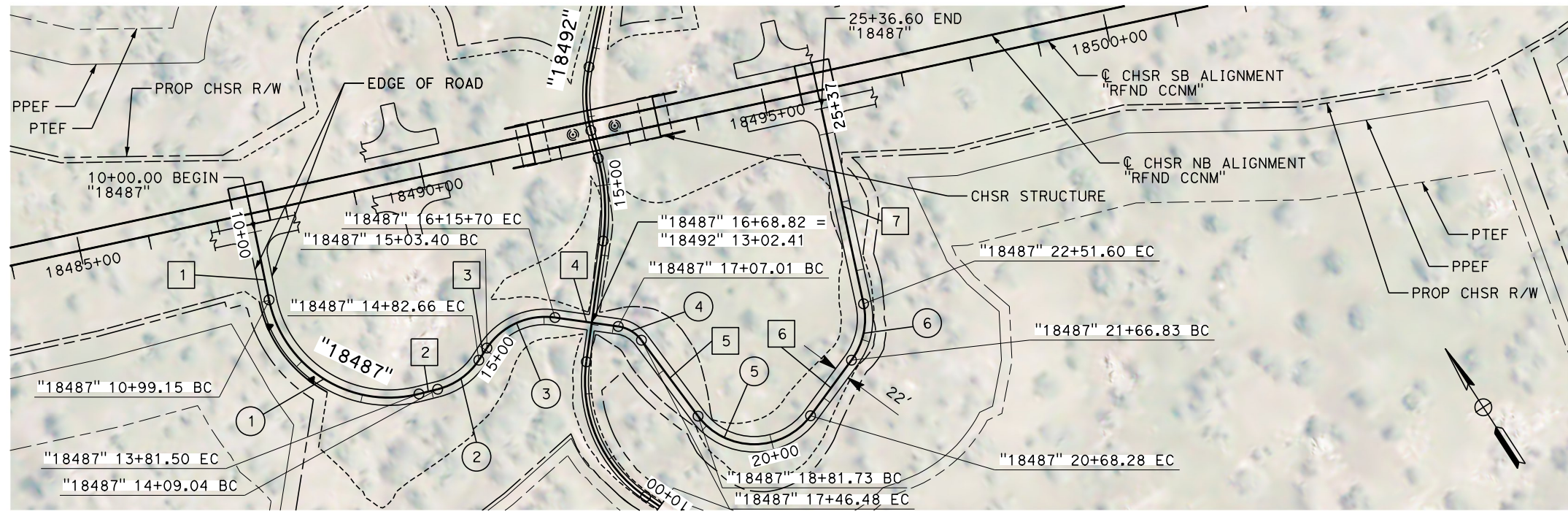

LINE DATA		
No.	BEARING	DISTANCE
1	S 21°16'50" E	99.15'
2	S 71°09'36" E	27.54'
3	N 66°39'29" E	20.74'
4	S 49°00'06" E	91.32'
5	S 3°46'09" E	135.25'
6	N 69°20'55" E	98.55'
7	N 20°46'36" E	285.00'

CURVE DATA				
No.	R	Δ	T	L
1	175.00'	92°26'26"	182.62'	282.34'
2	100.00'	42°10'55"	38.57'	73.62'
3	100.00'	64°20'25"	62.90'	112.29'
4	50.00'	45°13'57"	20.83'	39.47'
5	100.00'	106°52'56"	134.85'	186.54'
6	100.00'	48°34'19"	45.12'	84.77'

PLAN

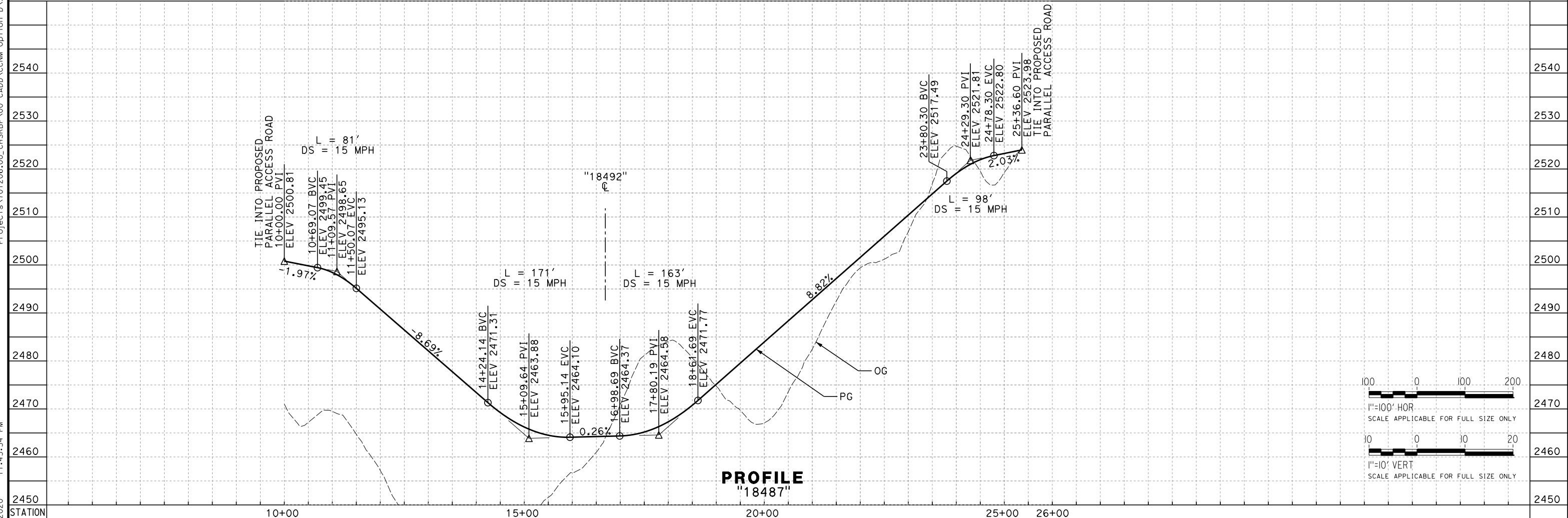

PROFILE
"18487"

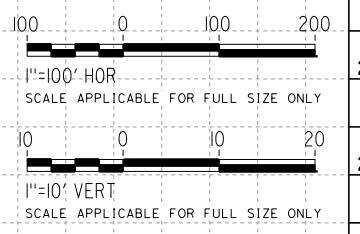

REV	DATE	BY	CHK	APP	DESCRIPTION

DESIGNED BY
A. CARSON
DRAWN BY
A. CARSON
CHECKED BY
D. HOLMAN
IN CHARGE
G. CAMPBELL
DATE
01/24/2020

**RECORD
PEPD
SUBMITTAL**

**NOT FOR
CONSTRUCTION**



CALIFORNIA HIGH-SPEED RAIL PROJECT
BAKERSFIELD TO PALMDALE
REFINED CCNM DESIGN OPTION
ROADWAY
ACCESS ROAD "18487"
PLAN AND PROFILE

CONTRACT NO.
HSR13-44
DRAWING NO.
CV-R1603
SCALE
AS SHOWN
SHEET NO.

Projects\701206.00_CHSRBP\00_CADD\CCNM_Option_D\Sheets\CV\BP-CV-R1603
 1/22/2020 11:45:54 PM
 andrew.carson@tylin.com



LINE DATA		
No.	BEARING	DISTANCE
1	N 22°29'20" W	24.74'
2	N 40°55'13" E	174.07'
3	N 18°10'58" E	41.04'
4	N 44°23'52" E	161.95'
5	N 26°56'11" E	33.09'

CURVE DATA				
No.	R	Δ	T	L
1	200.00'	63°24'32"	123.54'	221.34'
2	300.00'	22°44'14"	60.32'	119.05'
3	200.00'	26°12'54"	46.57'	91.51'
4	200.00'	17°27'41"	30.71'	60.95'

PLAN

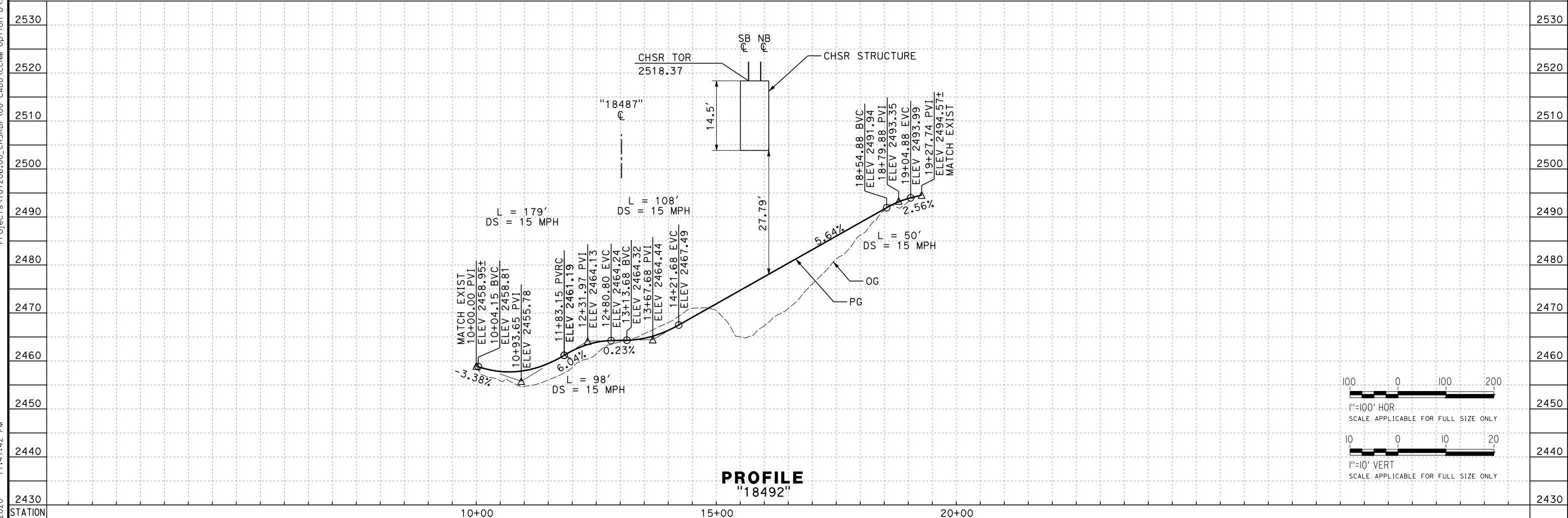

PROFILE
"18492"

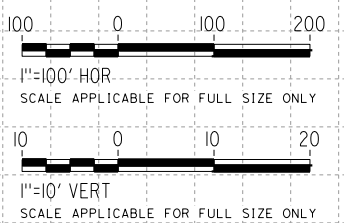

REV	DATE	BY	CHK	APP	DESCRIPTION

DESIGNED BY
A. CARSON
DRAWN BY
A. CARSON
CHECKED BY
D. HOLMAN
IN CHARGE
G. CAMPBELL
DATE
01/24/2020

**RECORD
PEPD
SUBMITTAL**

**NOT FOR
CONSTRUCTION**



CALIFORNIA HIGH-SPEED RAIL PROJECT
BAKERSFIELD TO PALMDALE
REFINED CCNM DESIGN OPTION
ROADWAY
DIRT ROAD "18492"
PLAN AND PROFILE

CONTRACT NO.
HSR13-44
DRAWING NO.
CV-R1604
SCALE
AS SHOWN
SHEET NO.

Projects\701206_00_CHSRBP\00_CADD\CCNM_Option_D\Sheets\CV\BP-CV-R1604 1/22/2020 11:47:42 PM andrew.carson@tylin.com

Projects\701206.00_CHSRBP\00_CADD\CCNM_Option D\Sheets\CV\BP-CV-R1605
 11:50:26 PM
 1/22/2020
 andrew.carson@tylin.com

LINE DATA		
No.	BEARING	DISTANCE
1	N 16°06'22" W	30.53'
2	N 1°56'15" E	292.63'
3	N 2°33'42" W	562.21'
4	N 71°47'59" E	105.94'
5	N 14°10'28" E	216.56'
6	N 5°50'36" E	102.29'
7	N 10°27'20" W	111.60'
8	N 3°21'11" E	498.99'
9	N 26°08'20" E	81.16'
10	N 9°37'19" W	139.06'
11	N 29°08'31" E	244.02'
12	N 70°50'12" W	113.52'
13	N 50°04'50" W	75.93'
14	N 36°03'50" W	129.65'
15	N 66°30'37" W	66.24'
16	N 36°58'47" W	99.88'
17	N 31°59'39" W	121.49'
18	N 56°23'50" W	58.34'
19	N 44°59'37" W	227.04'
20	N 61°56'46" W	118.85'
21	N 27°26'35" W	79.39'
22	N 9°52'43" W	130.74'
23	N 16°11'17" W	92.94'
24	N 48°43'29" E	40.47'
25	N 5°10'37" W	42.52'
26	N 30°50'34" E	118.37'
27	N 8°38'45" E	47.23'
28	N 27°08'35" E	156.67'
29	N 37°02'06" E	334.43'
30	N 2°40'27" E	59.12'
31	N 48°15'58" E	161.19'
32	N 29°49'24" E	163.66'
33	N 31°42'01" E	174.62'
34	N 60°31'34" W	323.79'
35	N 43°51'52" W	179.93'
36	N 20°46'25" E	24.56'

CURVE DATA				
No.	R	Δ	T	L
1	65.00'	18°02'37"	10.32'	20.47'
2	500.00'	4°29'57"	19.64'	39.26'
3	45.00'	74°21'41"	34.13'	58.40'
4	45.00'	57°37'31"	24.75'	45.26'
5	300.00'	8°19'52"	21.85'	43.62'
6	45.00'	16°17'56"	6.44'	12.80'
7	45.00'	13°48'31"	5.45'	10.85'
8	45.00'	22°47'09"	9.07'	17.90'
9	45.00'	35°45'39"	14.52'	28.09'
10	45.00'	38°45'50"	15.83'	30.45'
11	45.00'	99°58'44"	53.61'	78.52'
12	500.00'	20°45'23"	91.57'	181.13'
13	45.00'	14°01'00"	5.53'	11.01'
14	100.00'	30°26'47"	27.21'	53.14'
15	250.00'	29°31'50"	65.89'	128.85'
16	3000.00'	4°59'08"	130.61'	261.05'
17	200.00'	24°24'12"	43.25'	85.18'
18	300.00'	11°24'13"	29.95'	59.71'
19	300.00'	16°57'09"	44.71'	88.76'
20	150.00'	34°30'11"	46.58'	90.33'
21	500.00'	17°33'52"	77.25'	153.28'
22	250.00'	6°18'35"	13.78'	27.53'
23	250.00'	64°54'47"	159.00'	283.24'
24	100.00'	53°54'06"	50.84'	94.08'
25	150.00'	36°01'11"	48.77'	94.30'
26	500.00'	22°11'50"	98.08'	193.71'
27	250.00'	18°29'50"	40.71'	80.71'
28	750.00'	9°53'31"	64.90'	129.49'
29	150.00'	34°21'39"	46.38'	89.96'
30	100.00'	45°35'31"	42.03'	79.57'
31	500.00'	18°26'35"	81.17'	160.95'
32	2000.00'	1°52'37"	32.76'	65.52'
33	100.00'	92°13'35"	103.96'	160.97'
34	200.00'	16°39'43"	29.29'	58.16'
35	50.00'	64°38'17"	31.63'	56.41'

REV	DATE	BY	CHK	APP	DESCRIPTION

DESIGNED BY
A. CARSON
 DRAWN BY
A. CARSON
 CHECKED BY
D. HOLMAN
 IN CHARGE
G. CAMPBELL
 DATE
01/24/2020

**RECORD
 PEPD
 SUBMITTAL**

**NOT FOR
 CONSTRUCTION**



CALIFORNIA HIGH-SPEED RAIL PROJECT
BAKERSFIELD TO PALMDALE
 REFINED CCNM DESIGN OPTION
 ROADWAY
 ACCESS ROAD "18507"
 HORIZONTAL ALIGNMENT DATA TABLE

CONTRACT NO.
 HSR13-44
 DRAWING NO.
 CV-R1605
 SCALE
 NO SCALE
 SHEET NO.

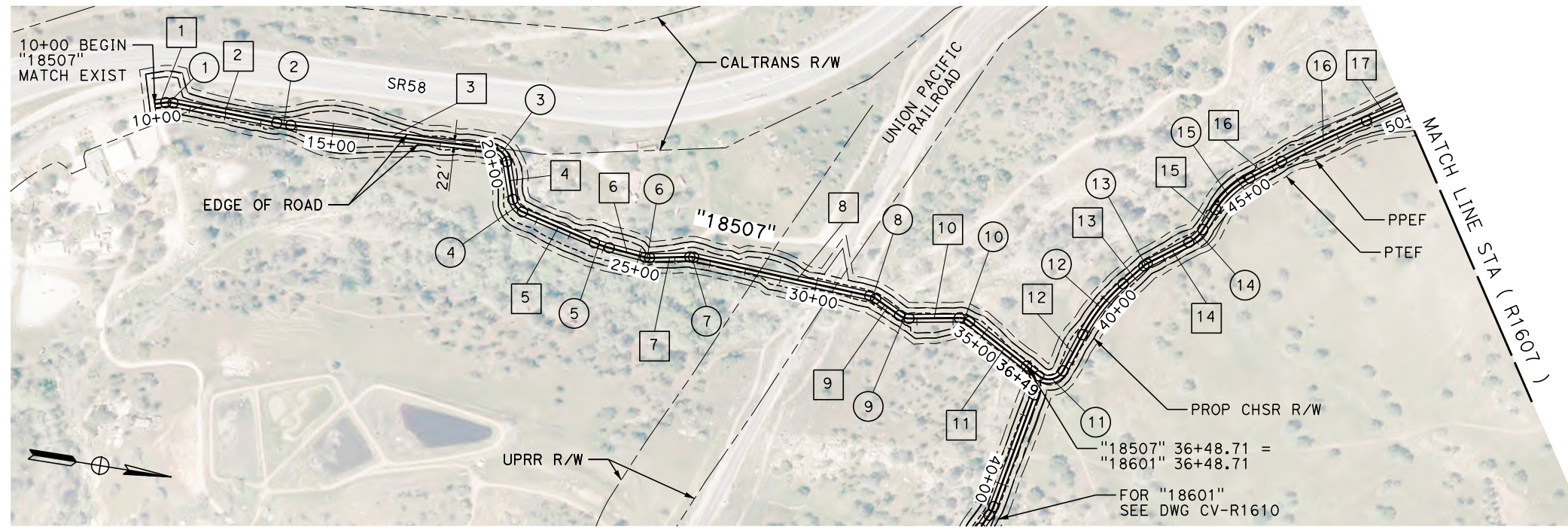

PLAN

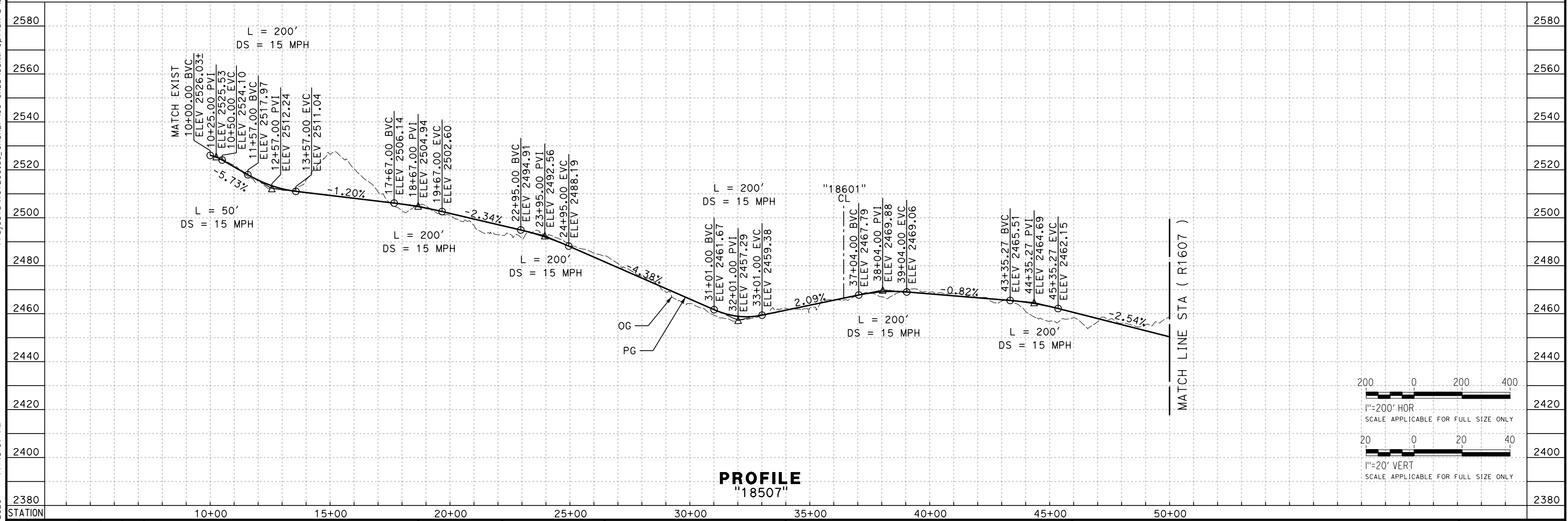

PROFILE
"18507"

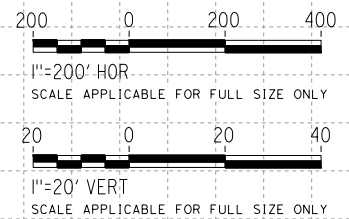

REV	DATE	BY	CHK	APP	DESCRIPTION

DESIGNED BY
A. CARSON
DRAWN BY
A. CARSON
CHECKED BY
D. HOLMAN
IN CHARGE
G. CAMPBELL
DATE
01/24/2020

**RECORD
PEPD
SUBMITTAL**

**NOT FOR
CONSTRUCTION**



CALIFORNIA HIGH-SPEED RAIL PROJECT
BAKERSFIELD TO PALMDALE
REFINED CCNM DESIGN OPTION
ROADWAY
ACCESS ROAD "18507"
PLAN AND PROFILE - SHEET 1 OF 2

CONTRACT NO.
HSR13-44
DRAWING NO.
CV-R1606
SCALE
AS SHOWN
SHEET NO.

Projects\701206.00_CHSRBP\00_CADD\CCNM_Option_D\Sheets\CV\BP-CV-R1606
 1/22/2020 11:46:01 PM
 andrew.carson@tylin.com

Projects\T01206\00_CHSRBP\00_CADD\CCNM_Option D\Sheets\CV\BP-CV-R1607
 1/22/2020 11:48:44 PM
 andrew.carson@tylin.com

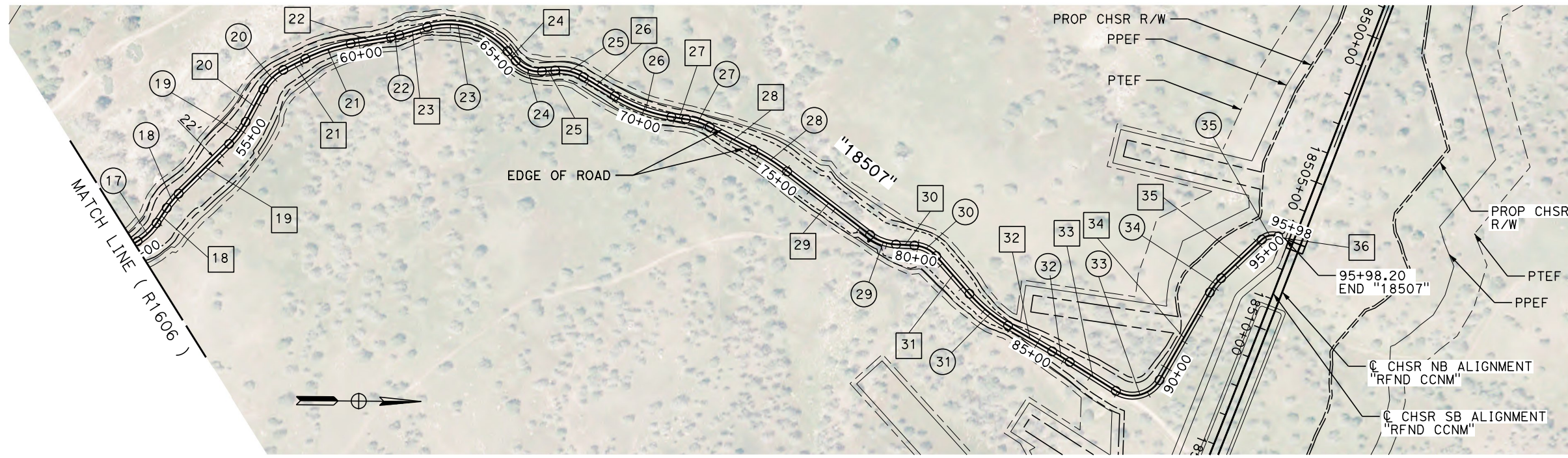

PLAN

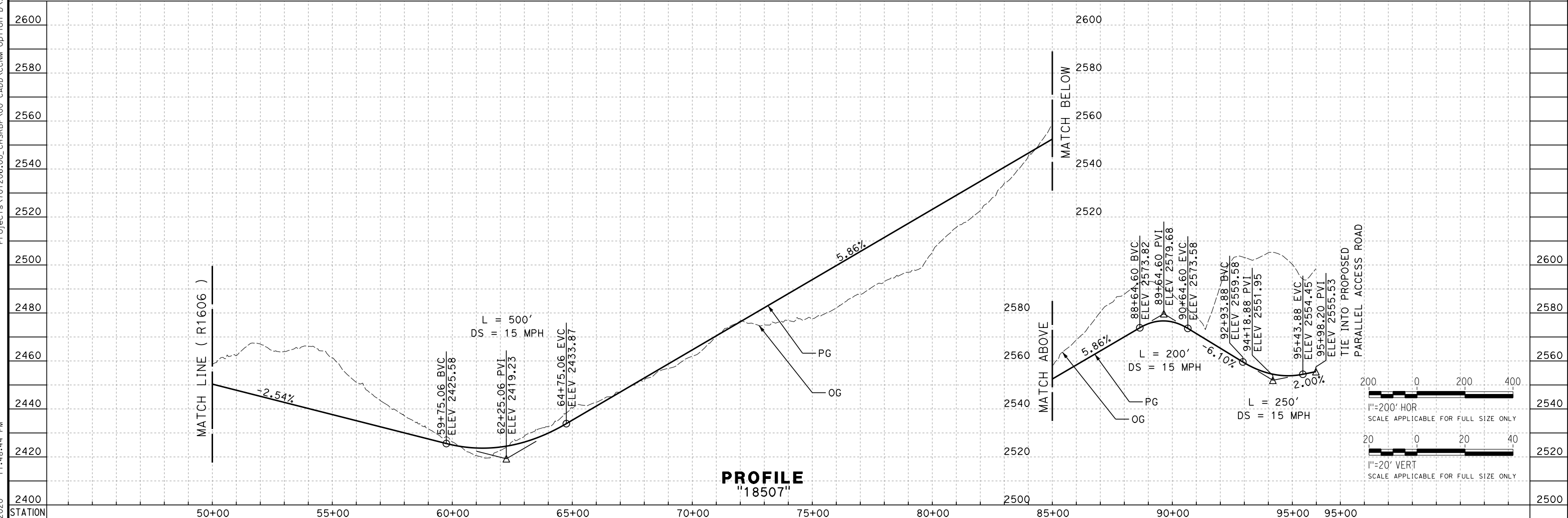

PROFILE
"18507"

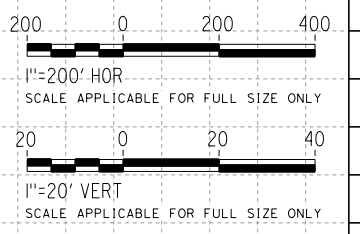

REV	DATE	BY	CHK	APP	DESCRIPTION

DESIGNED BY
A. CARSON
 DRAWN BY
A. CARSON
 CHECKED BY
D. HOLMAN
 IN CHARGE
G. CAMPBELL
 DATE
01/24/2020

**RECORD
PEPD
SUBMITTAL**

**NOT FOR
CONSTRUCTION**



CALIFORNIA HIGH-SPEED RAIL PROJECT
BAKERSFIELD TO PALMDALE
 REFINED CCNM DESIGN OPTION
 ROADWAY
 ACCESS ROAD "18507"
 PLAN AND PROFILE - SHEET 2 OF 2

CONTRACT NO.
HSR13-44
 DRAWING NO.
CV-R1607
 SCALE
AS SHOWN
 SHEET NO.

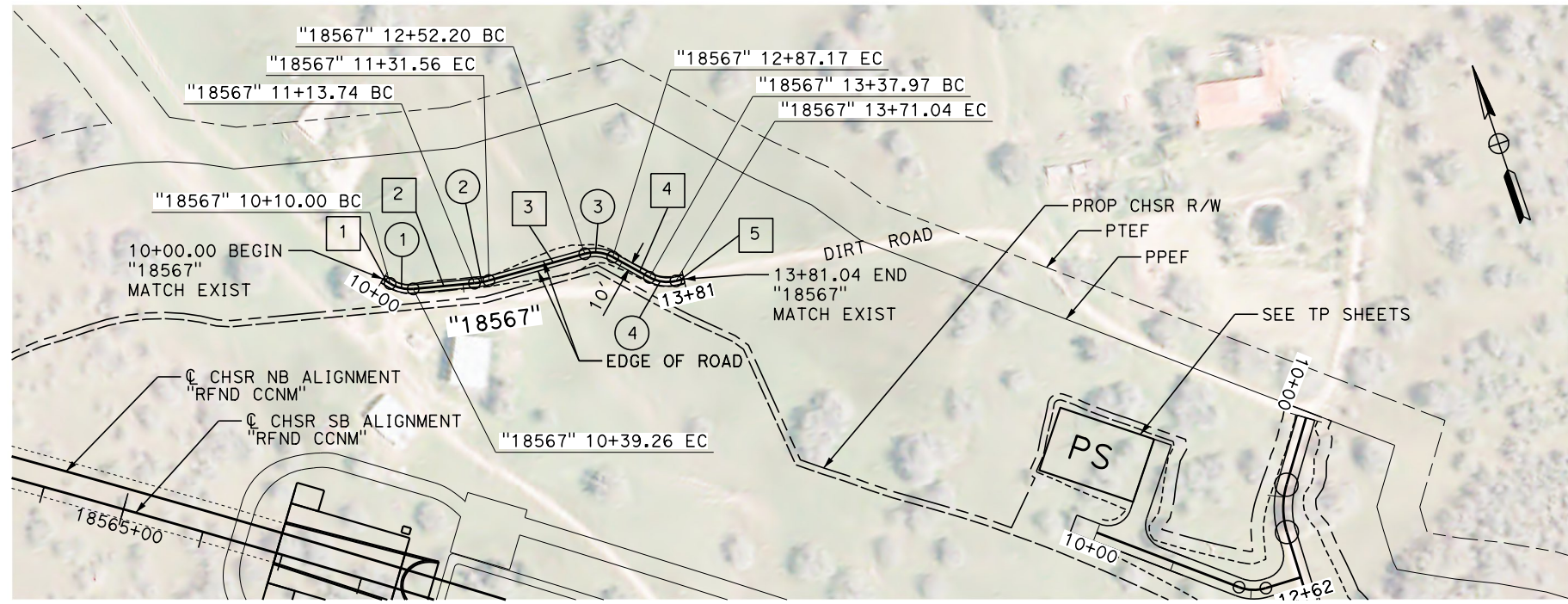

LINE DATA		
No.	BEARING	DISTANCE
1	S 39°22'50" E	10.00'
2	S 76°38'17" E	74.47'
3	S 86°51'10" E	120.64'
4	S 42°19'38" E	50.80'
5	S 84°25'58" E	10.00'

CURVE DATA				
No.	R	Δ	T	L
1	45.00'	37°15'27"	15.17'	29.26'
2	100.00'	10°12'53"	8.94'	17.83'
3	45.00'	44°31'32"	18.42'	34.97'
4	45.00'	42°06'20"	17.32'	33.07'

PLAN

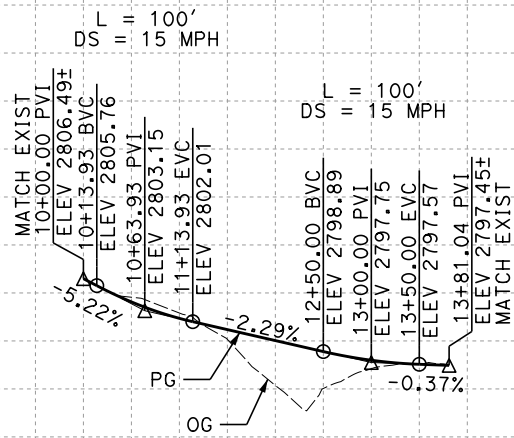

PROFILE
"18567"

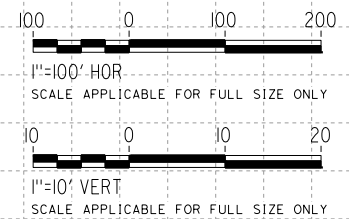

Projects\T01206.00_CHSRBP\00_CADD\CCNM_Option D\Sheets\CV\BP-CV-R1608
 1/22/2020 11:47:41 PM
 andrew.carson@tylin.com

REV	DATE	BY	CHK	APP	DESCRIPTION

DESIGNED BY
A. CARSON
 DRAWN BY
A. CARSON
 CHECKED BY
D. HOLMAN
 IN CHARGE
G. CAMPBELL
 DATE
01/24/2020

**RECORD
PEPD
SUBMITTAL**

**NOT FOR
CONSTRUCTION**



CALIFORNIA HIGH-SPEED RAIL PROJECT
BAKERSFIELD TO PALMDALE
 REFINED CCNM DESIGN OPTION
 ROADWAY
 DIRT ROAD "18567"
 PLAN AND PROFILE

CONTRACT NO.
HSR13-44
 DRAWING NO.
CV-R1608
 SCALE
AS SHOWN
 SHEET NO.

Projects\701206.00_CHSRBP\00_CADD\CCNM_Option D\Sheets\CV\BP-CV-R1609
 1/22/2020 11:47:27 PM
 andrew.carson@tylin.com

LINE DATA		
No.	BEARING	DISTANCE
1	S 78°53'19" E	329.77'
2	S 63°31'48" E	43.67'
3	S 89°54'06" E	416.97'
4	S 55°36'12" E	148.68'
5	S 87°23'23" E	53.03'
6	S 58°48'48" E	71.67'
7	N 56°08'58" E	90.66'
8	S 80°48'24" E	75.87'
9	N 71°55'24" E	125.53'
10	N 83°29'51" E	200.57'
11	N 69°48'41" E	51.45'
12	S 85°55'26" E	149.72'
13	S 89°47'55" E	121.07'
14	S 74°43'48" E	141.05'
15	S 89°37'18" E	273.79'
16	S 32°10'21" E	575.76'
17	S 52°09'43" E	53.49'
18	N 43°47'16" E	77.84'
19	N 70°44'22" E	103.71'
20	N 84°59'24" E	247.30'
21	N 50°00'46" E	205.17'
22	N 71°14'54" E	457.34'
23	N 74°36'10" E	140.99'
24	N 72°33'03" E	358.72'
25	S 68°06'38" E	54.54'
26	S 88°54'00" E	67.09'
27	S 67°42'33" E	35.86'
28	N 84°19'27" E	40.66'
29	S 87°26'36" E	75.44'
30	N 86°37'21" E	157.73'
31	S 70°14'14" E	118.67'
32	S 63°53'12" E	153.21'
33	N 75°44'03" E	157.59'
34	S 83°40'53" E	467.04'

CURVE DATA				
No.	R	Δ	T	L
1	70.00'	71°58'09"	50.83'	87.93'
2	100.00'	15°21'31"	13.48'	26.81'
3	100.00'	26°22'18"	23.43'	46.03'
4	45.00'	34°17'54"	13.89'	26.94'
5	100.00'	31°47'11"	28.47'	55.48'
6	100.00'	28°34'35"	25.47'	49.88'
7	45.00'	65°02'14"	28.69'	51.08'
8	45.00'	43°02'37"	17.75'	33.81'
9	45.00'	27°16'12"	10.92'	21.42'
10	200.00'	11°34'27"	20.27'	40.40'
11	100.00'	13°41'10"	12.00'	23.89'
12	100.00'	24°15'53"	21.50'	42.35'
13	100.00'	3°52'29"	3.38'	6.76'
14	100.00'	15°04'07"	13.23'	26.30'
15	100.00'	14°53'30"	13.07'	25.99'
16	100.00'	57°26'57"	54.80'	100.27'
17	200.00'	19°59'22"	35.25'	69.78'
18	50.00'	84°03'00"	45.06'	73.35'
19	200.00'	26°57'05"	47.93'	94.08'
20	250.00'	14°15'03"	31.25'	62.18'
21	200.00'	34°58'38"	63.02'	122.09'
22	200.00'	21°14'08"	37.49'	74.13'
23	2000.00'	3°21'16"	58.56'	117.09'
24	1000.00'	2°03'07"	17.91'	35.81'
25	200.00'	39°20'18"	71.49'	137.32'
26	300.00'	20°47'22"	55.03'	108.85'
27	500.00'	21°11'27"	93.53'	184.93'
28	100.00'	27°58'00"	24.90'	48.81'
29	500.00'	8°13'57"	35.98'	71.84'
30	500.00'	5°56'03"	25.92'	51.79'
31	300.00'	23°08'25"	61.42'	121.16'
32	1000.00'	6°21'02"	55.48'	110.84'
33	400.00'	40°22'45"	147.09'	281.90'
34	400.00'	20°35'04"	72.64'	143.71'

REV	DATE	BY	CHK	APP	DESCRIPTION

DESIGNED BY
A. CARSON
 DRAWN BY
A. CARSON
 CHECKED BY
D. HOLMAN
 IN CHARGE
G. CAMPBELL
 DATE
01/24/2020

**RECORD
 PEPD
 SUBMITTAL**

**NOT FOR
 CONSTRUCTION**



CALIFORNIA HIGH-SPEED RAIL PROJECT
BAKERSFIELD TO PALMDALE
 REFINED CCNM DESIGN OPTION
 ROADWAY
 ACCESS ROAD "18601"
 HORIZONTAL ALIGNMENT DATA TABLE

CONTRACT NO.
 HSR13-44
 DRAWING NO.
 CV-R1609
 SCALE
 NO SCALE
 SHEET NO.

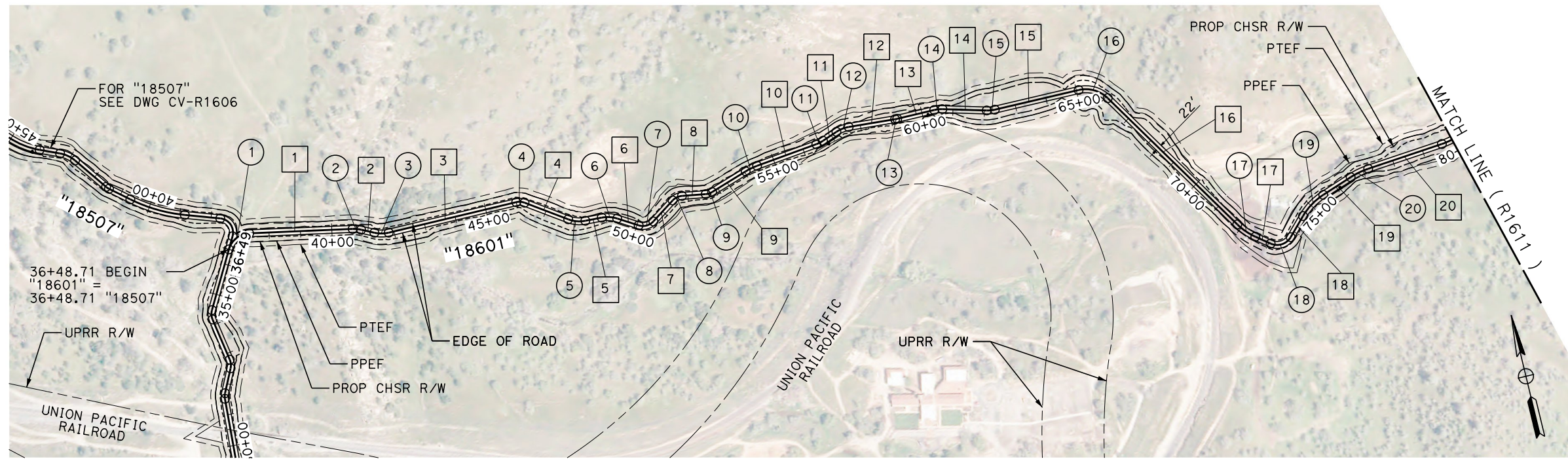

PLAN

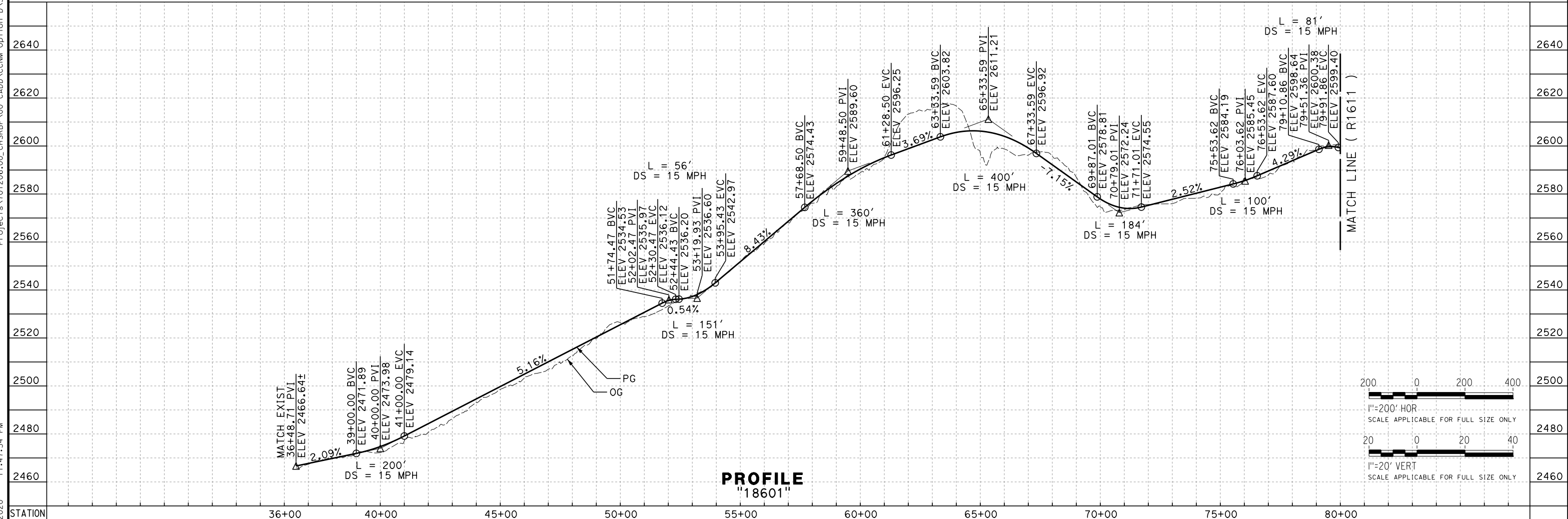

PROFILE
"18601"

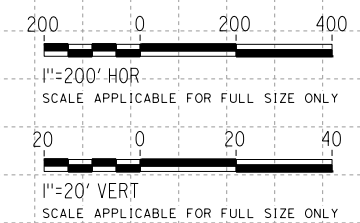

REV	DATE	BY	CHK	APP	DESCRIPTION

DESIGNED BY
A. CARSON
DRAWN BY
A. CARSON
CHECKED BY
D. HOLMAN
IN CHARGE
G. CAMPBELL
DATE
01/24/2020

**RECORD
PEPD
SUBMITTAL**

**NOT FOR
CONSTRUCTION**



CALIFORNIA HIGH-SPEED RAIL PROJECT
BAKERSFIELD TO PALMDALE
REFINED CCNM DESIGN OPTION
ROADWAY
ACCESS ROAD "18601"
PLAN AND PROFILE - SHEET 1 OF 2

CONTRACT NO.
HSR13-44
DRAWING NO.
CV-R1610
SCALE
AS SHOWN
SHEET NO.

Projects\701206\00_CHSRBP\00_CADD\CCNM Option D\Sheets\CV\BP-CV-R1610
 1/22/2020 11:47:34 PM
 andrew.carson@tylin.com

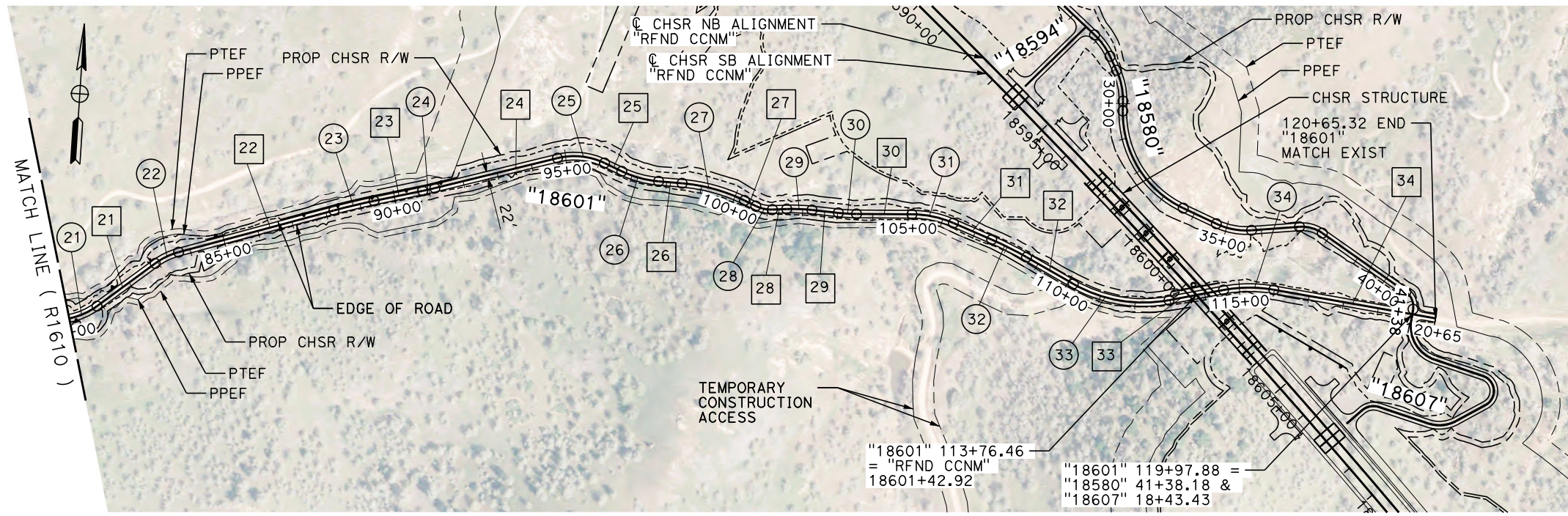

PLAN

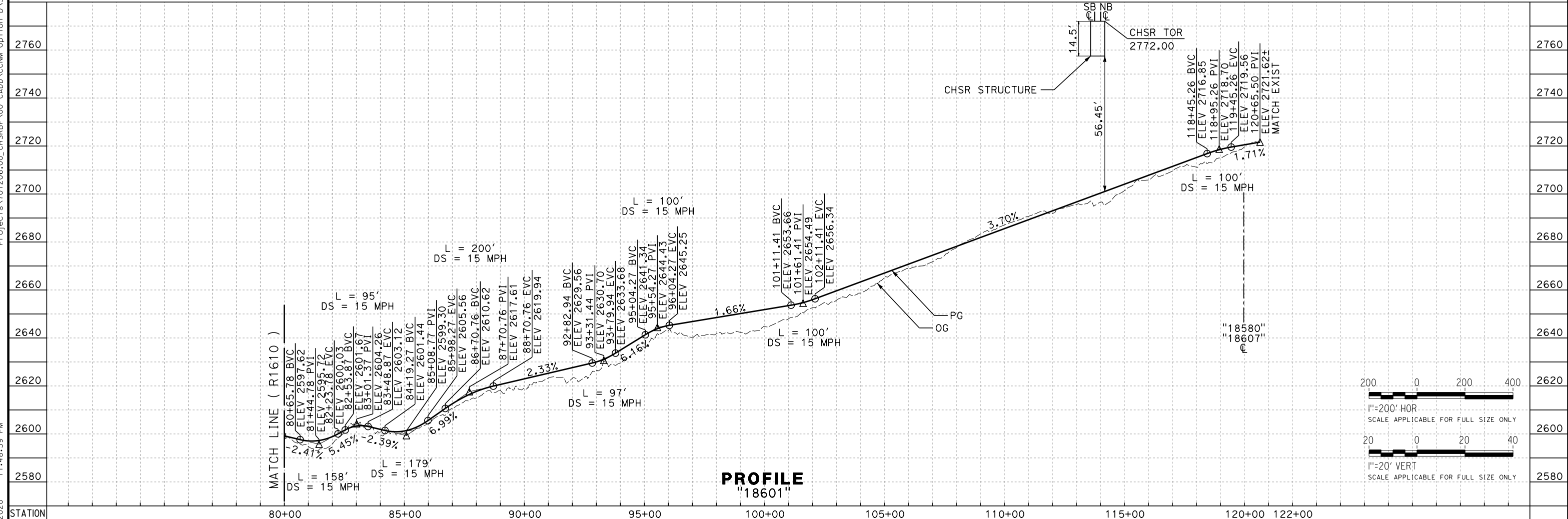

PROFILE
"18601"

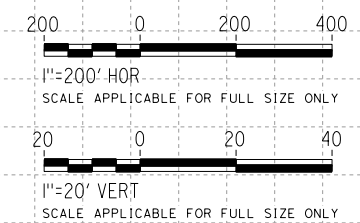

REV	DATE	BY	CHK	APP	DESCRIPTION

DESIGNED BY
A. CARSON
DRAWN BY
A. CARSON
CHECKED BY
D. HOLMAN
IN CHARGE
G. CAMPBELL
DATE
01/24/2020

**RECORD
PEPD
SUBMITTAL**

**NOT FOR
CONSTRUCTION**



CALIFORNIA HIGH-SPEED RAIL PROJECT
BAKERSFIELD TO PALMDALE
REFINED CCNM DESIGN OPTION
ROADWAY
ACCESS ROAD "18601"
PLAN AND PROFILE - SHEET 2 OF 2

CONTRACT NO.
HSR13-44
DRAWING NO.
CV-R1611
SCALE
AS SHOWN
SHEET NO.

Projects\701206.00_CHSRBP\00_CADD\CCNM_Option D\Sheets\CV\BP-CV-R1611
 11:48:39 PM
 1/22/2020
 andrew.carson@tylin.com

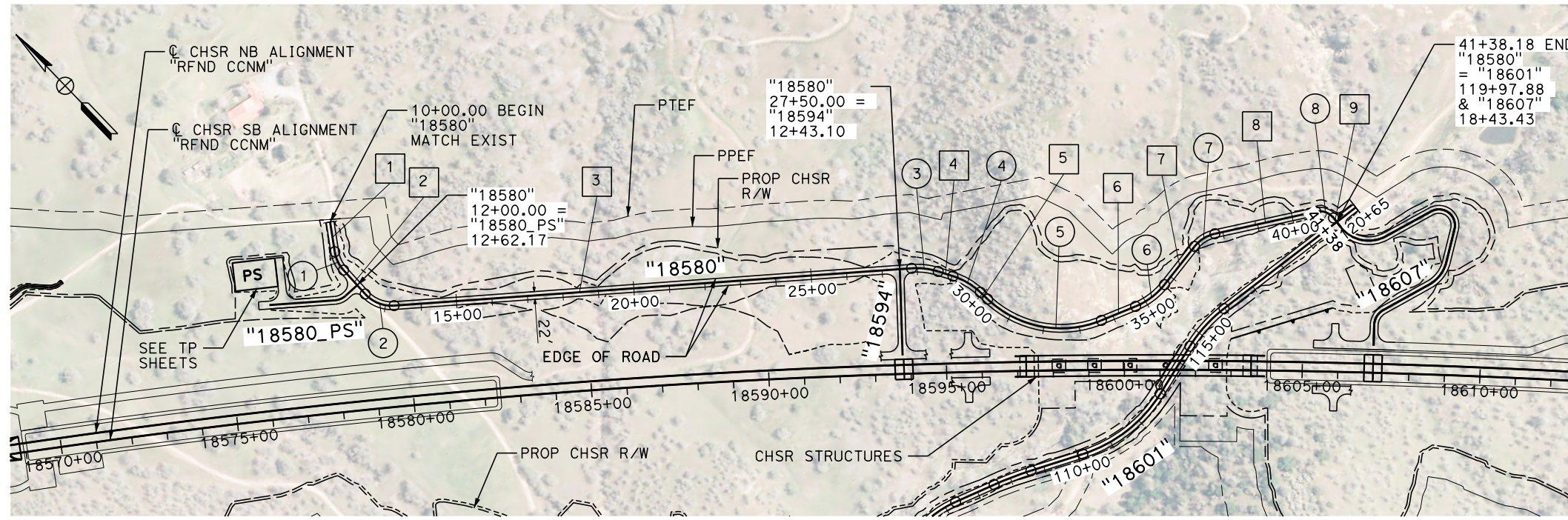

PLAN

LINE DATA		
No.	BEARING	DISTANCE
1	S 34°57'53" W	84.50'
2	S 1°39'27" W	90.79'
3	S 50°17'13" E	1459.05'
4	S 28°38'06" E	43.64'
5	S 2°44'40" E	28.29'
6	S 68°25'37" E	104.00'
7	N 82°04'17" E	136.57'
8	S 58°31'46" E	290.42'
9	S 5°29'37" W	14.65'

CURVE DATA				
No.	R	Δ	T	L
1	100.00'	33°18'26"	29.91'	58.13'
2	100.00'	51°56'40"	48.71'	90.66'
3	200.00'	21°43'07"	38.37'	75.81'
4	200.00'	25°49'26"	45.85'	90.14'
5	300.00'	65°40'57"	193.64'	343.91'
6	200.00'	29°30'06"	52.66'	102.98'
7	100.00'	38°23'57"	35.80'	68.76'
8	50.00'	64°01'22"	31.26'	55.87'

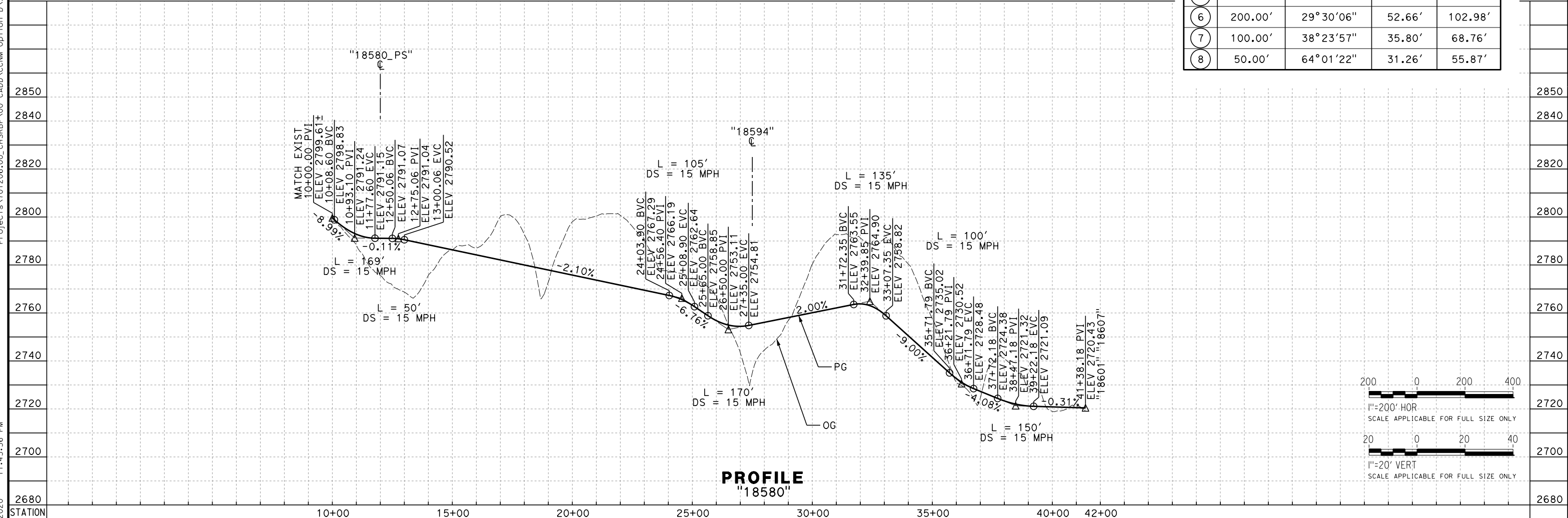

PROFILE
"18580"

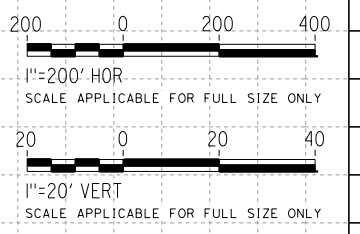

REV	DATE	BY	CHK	APP	DESCRIPTION

DESIGNED BY
A. CARSON
DRAWN BY
A. CARSON
CHECKED BY
D. HOLMAN
IN CHARGE
G. CAMPBELL
DATE
01/24/2020

**RECORD
PEPD
SUBMITTAL**

**NOT FOR
CONSTRUCTION**



CALIFORNIA HIGH-SPEED RAIL PROJECT
BAKERSFIELD TO PALMDALE
REFINED CCNM DESIGN OPTION
ROADWAY
ACCESS ROAD "18580"
PLAN AND PROFILE

CONTRACT NO.
HSR13-44
DRAWING NO.
CV-R1612
SCALE
AS SHOWN
SHEET NO.

Projects\701206.00_CHSRBP\00_CADD\CCNM_Option_D\Sheets\CV\BP-CV-R1612
 1/22/2020 11:45:56 PM
 andrew.carson@tylin.com

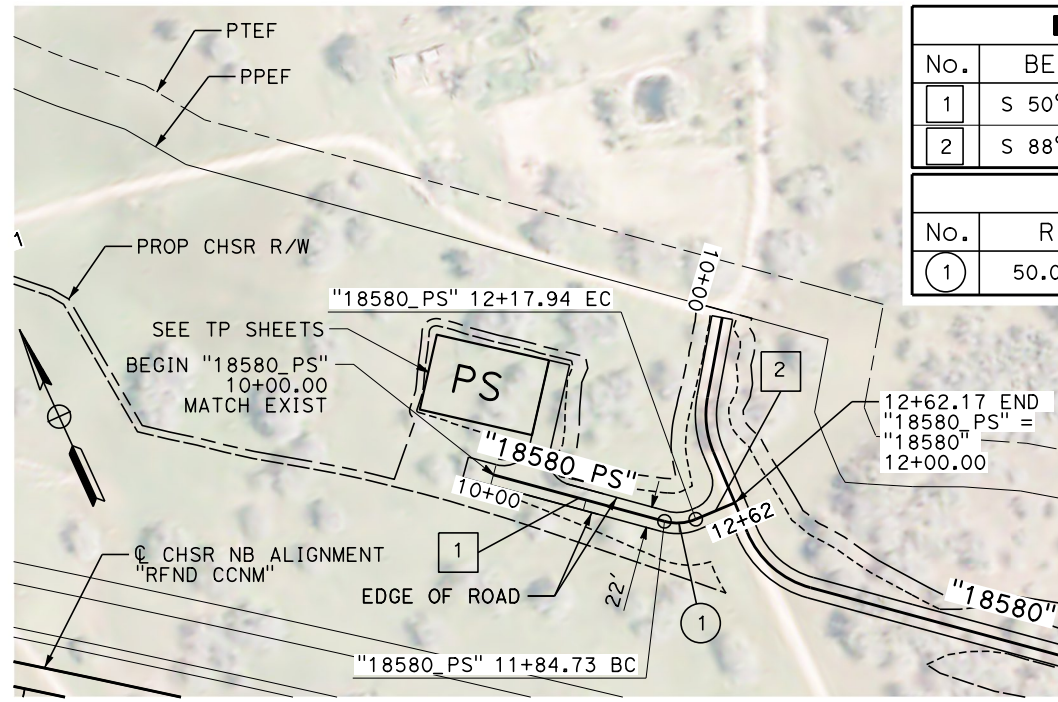

LINE DATA		
No.	BEARING	DISTANCE
1	S 50°17'13" E	184.73'
2	S 88°20'33" E	44.23'

CURVE DATA				
No.	R	Δ	T	L
1	50.00'	38°03'20"	17.24'	33.21'

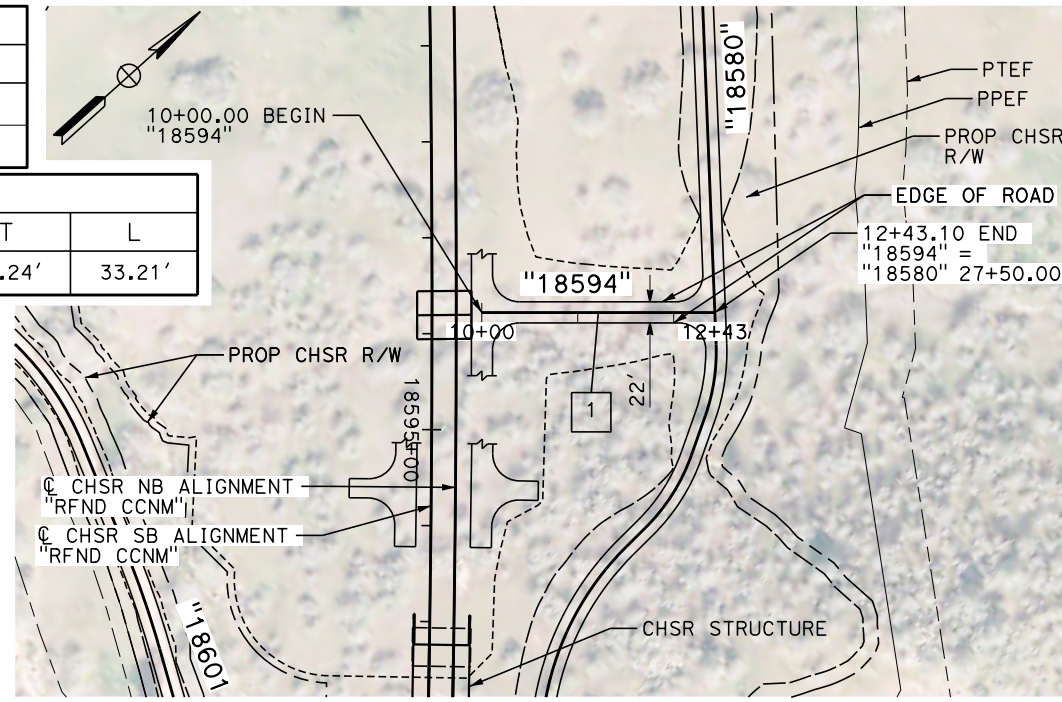

LINE DATA		
No.	BEARING	DISTANCE
1	N 41°58'36" E	242.88'

PLAN

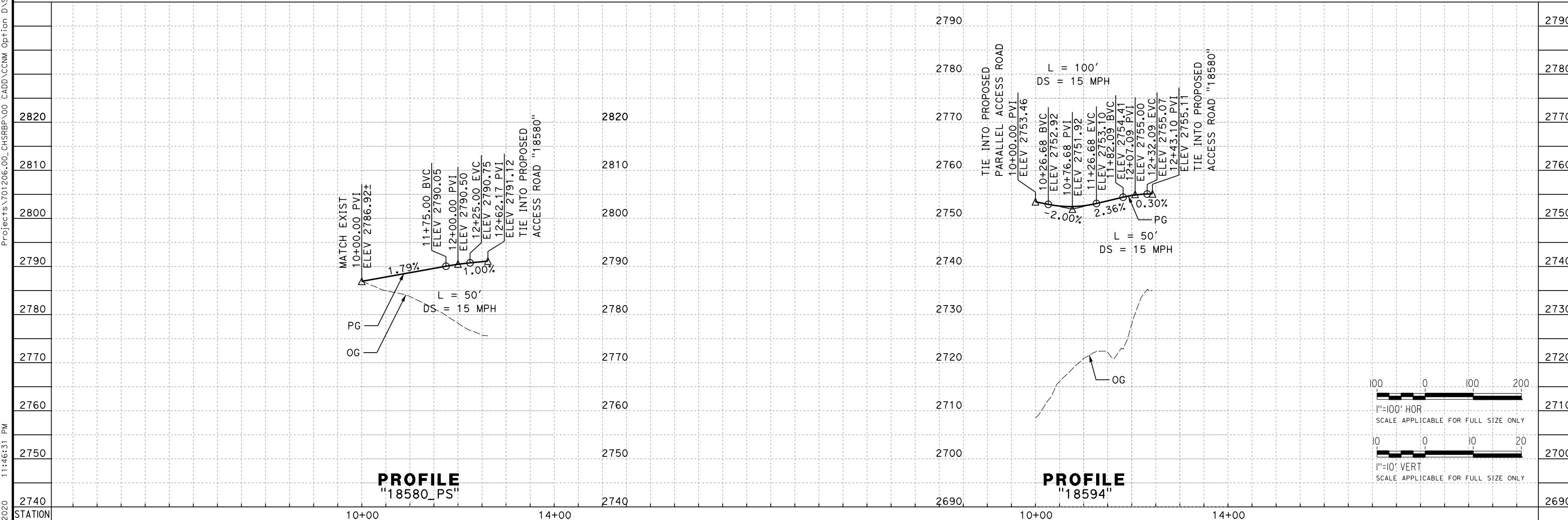

PROFILE "18580_PS"

PROFILE "18594"

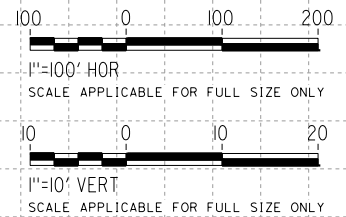

REV	DATE	BY	CHK	APP	DESCRIPTION

DESIGNED BY
A. CARSON
DRAWN BY
A. CARSON
CHECKED BY
D. HOLMAN
IN CHARGE
G. CAMPBELL
DATE
01/24/2020

**RECORD
PEPD
SUBMITTAL**

**NOT FOR
CONSTRUCTION**



CALIFORNIA HIGH-SPEED RAIL PROJECT
BAKERSFIELD TO PALMDALE
REFINED CCNM DESIGN OPTION
ROADWAY
ACCESS ROAD "18580_PS" & "18594"
PLAN AND PROFILE

CONTRACT NO.
HSR13-44
DRAWING NO.
CV-R1613
SCALE
AS SHOWN
SHEET NO.

Projects\701206_00_CHSRBP\00_CADD\CCNM_Option D\Sheets\CV\BP-CV-R1613
 1/22/2020 11:46:31 PM
 andrew.carson@tylin.com

Projects\701206.00_CHSRBP\00_CADD\CCNM_Option D\Sheets\CV\BP-CV-R1614
 1/22/2020 11:48:13 PM
 andrew.carson@tylin.com

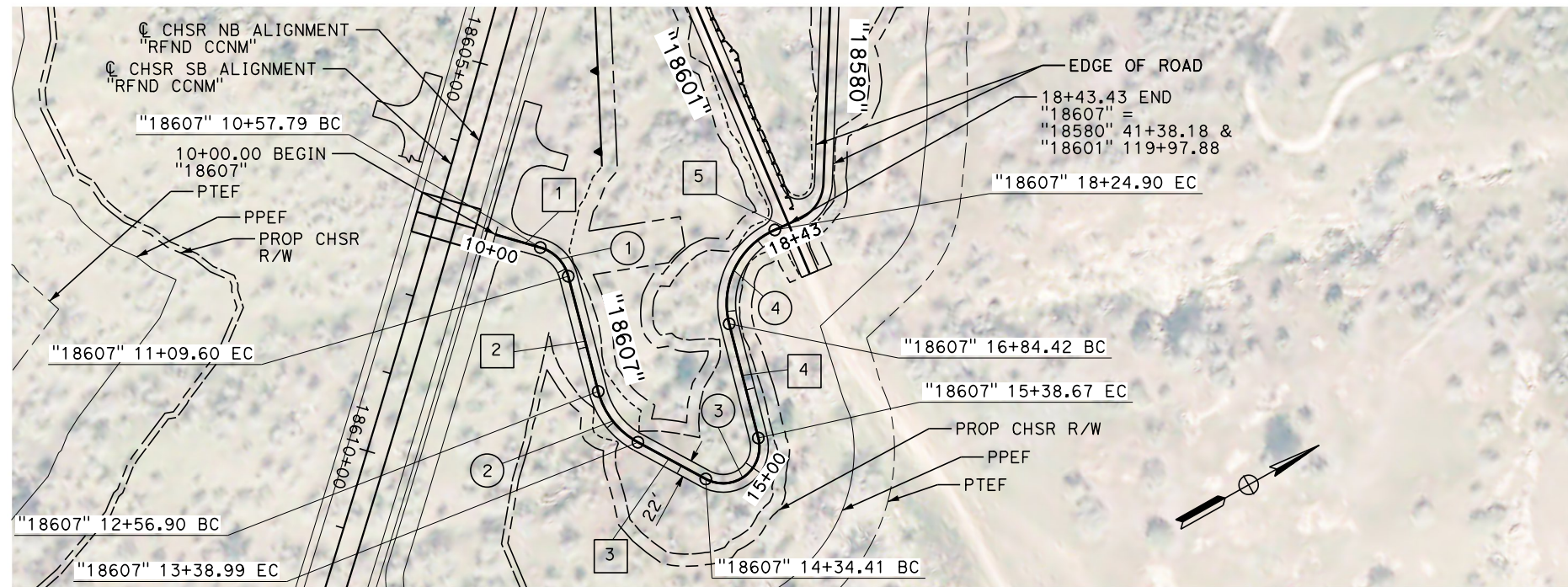

PLAN

LINE DATA		
No.	BEARING	DISTANCE
1	N 45°25'02" E	57.79'
2	S 75°12'52" E	147.30'
3	N 57°44'54" E	95.42'
4	N 74°59'50" W	145.75'
5	N 5°29'37" E	18.53'

CURVE DATA				
No.	R	Δ	T	L
1	50.00'	59°22'06"	28.50'	51.81'
2	100.00'	47°02'14"	43.52'	82.10'
3	45.00'	132°44'44"	102.87'	104.26'
4	100.00'	80°29'27"	84.64'	140.48'

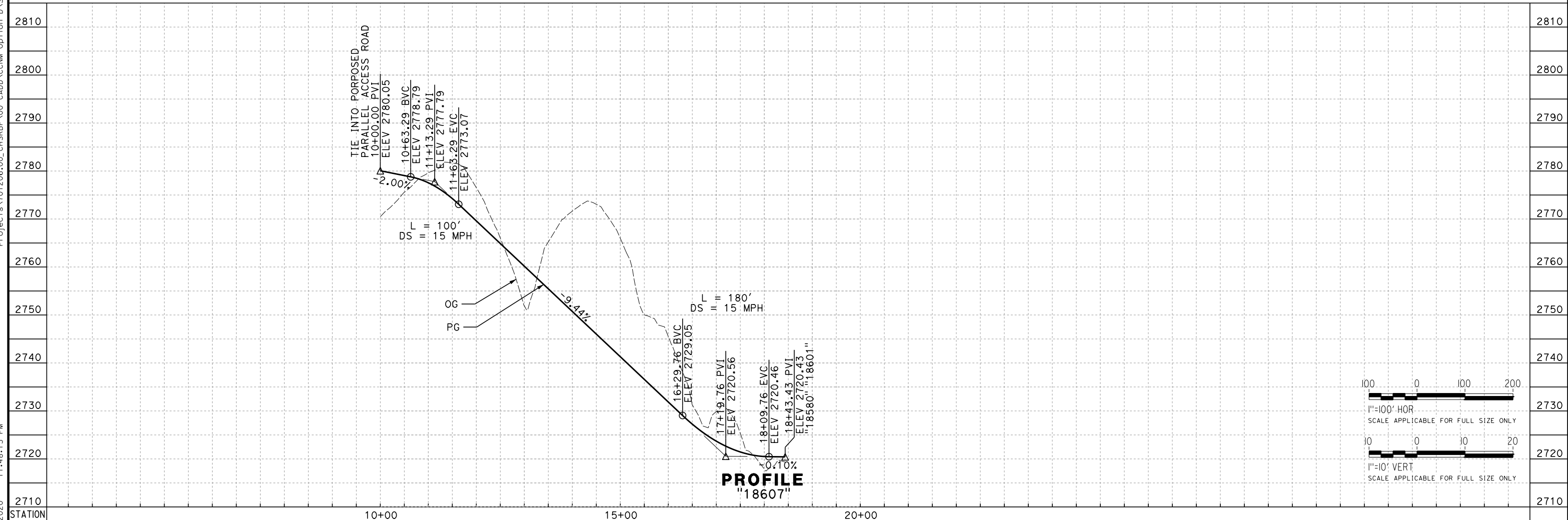

PROFILE
"18607"

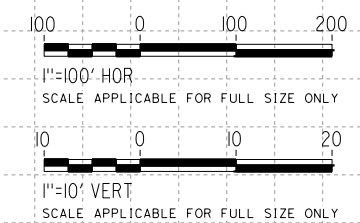

REV	DATE	BY	CHK	APP	DESCRIPTION

DESIGNED BY
A. CARSON
 DRAWN BY
A. CARSON
 CHECKED BY
D. HOLMAN
 IN CHARGE
G. CAMPBELL
 DATE
01/24/2020

**RECORD
 PECD
 SUBMITTAL**

**NOT FOR
 CONSTRUCTION**



CALIFORNIA HIGH-SPEED RAIL PROJECT
BAKERSFIELD TO PALMDALE
 REFINED CCNM DESIGN OPTION
 ROADWAY
 ACCESS ROAD "18607"
 PLAN AND PROFILE

CONTRACT NO.
HSR13-44
 DRAWING NO.
CV-R1614
 SCALE
AS SHOWN
 SHEET NO.

Projects\701206.00_CHSRBP\00_CADD\CCNM_Option D\Sheets\CV\BP-CV-R1615
 11:50:04 PM
 1/22/2020
 andrew.carson@tylin.com

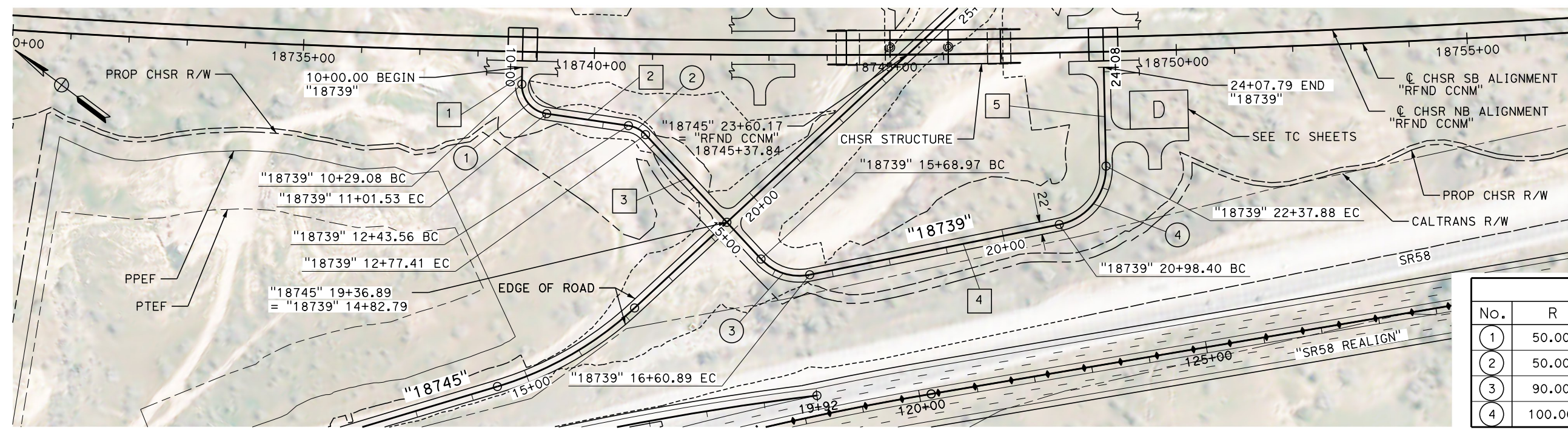

LINE DATA		
NO.	BEARING	DISTANCE
1	S 54°28'33" E	29.08'
2	S 28°32'10" E	142.03'
3	S 10°15'20" W	291.56'
4	S 48°15'43" E	437.51'
5	N 51°49'24" E	169.91'

CURVE DATA				
NO.	R	Δ	T	L
1	50.00'	83°00'42"	44.25'	72.44'
2	50.00'	38°47'30"	17.60'	33.85'
3	90.00'	58°31'03"	50.42'	91.92'
4	100.00'	79°54'53"	83.78'	139.48'

PLAN

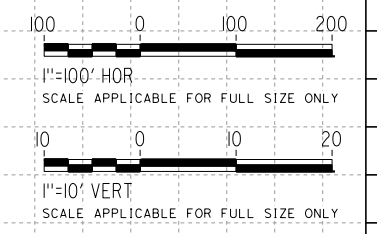
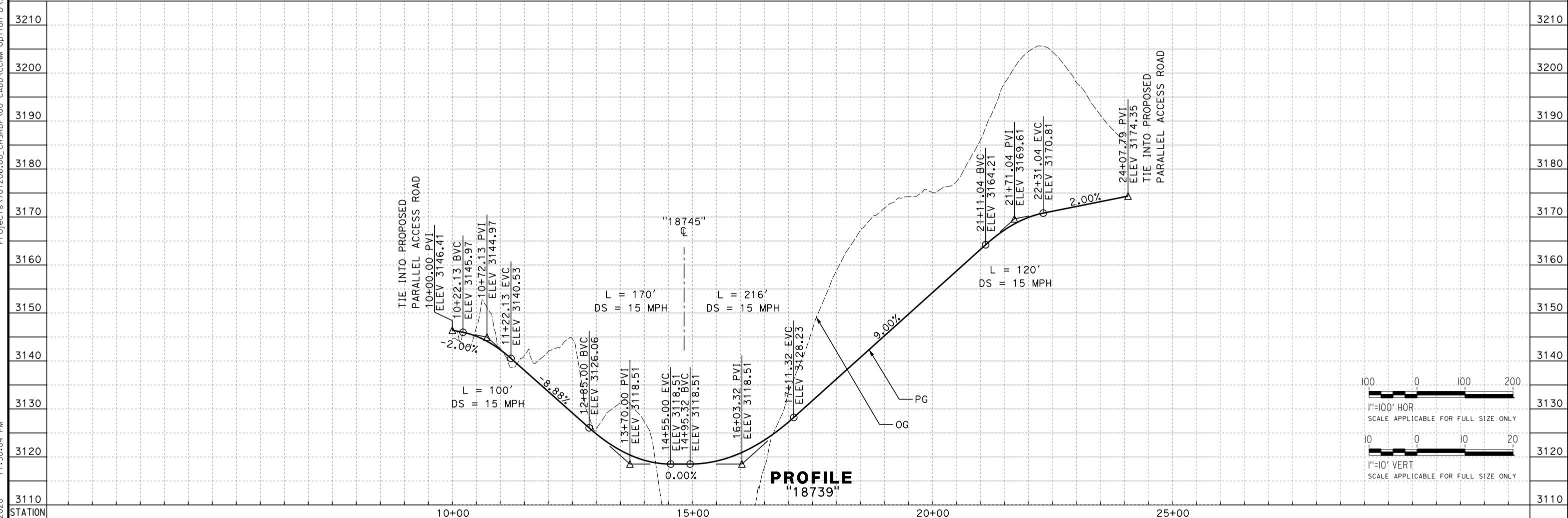

PROFILE
"18739"

REV	DATE	BY	CHK	APP	DESCRIPTION

DESIGNED BY
A. CARSON
 DRAWN BY
A. CARSON
 CHECKED BY
D. HOLMAN
 IN CHARGE
G. CAMPBELL
 DATE
01/24/2020

**RECORD
PEPD
SUBMITTAL**

**NOT FOR
CONSTRUCTION**



CALIFORNIA HIGH-SPEED RAIL PROJECT
BAKERSFIELD TO PALMDALE
 REFINED CCNM DESIGN OPTION
 ROADWAY
 ACCESS ROAD "18739"
 PLAN AND PROFILE

CONTRACT NO.
HSR13-44
 DRAWING NO.
CV-R1615
 SCALE
AS SHOWN
 SHEET NO.

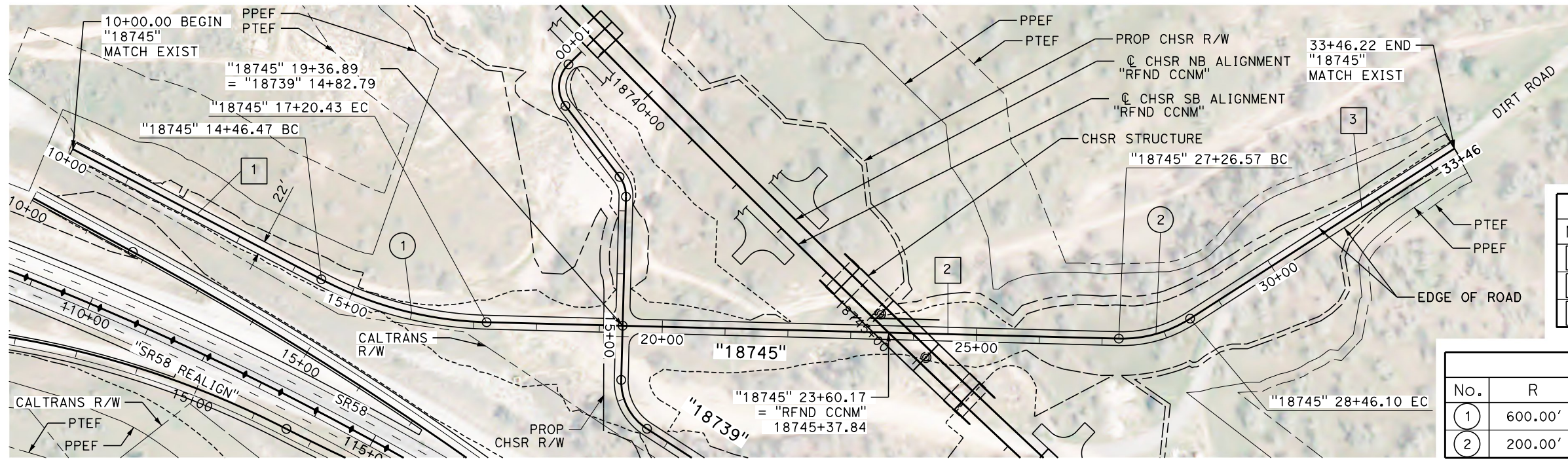

LINE DATA		
No.	BEARING	DISTANCE
1	S 53°34'59" E	446.47'
2	S 79°44'40" E	1006.14'
3	N 66°00'44" E	500.12'

CURVE DATA				
No.	R	Δ	T	L
1	600.00'	26°09'41"	139.41'	273.96'
2	200.00'	34°14'36"	61.61'	119.53'

PLAN

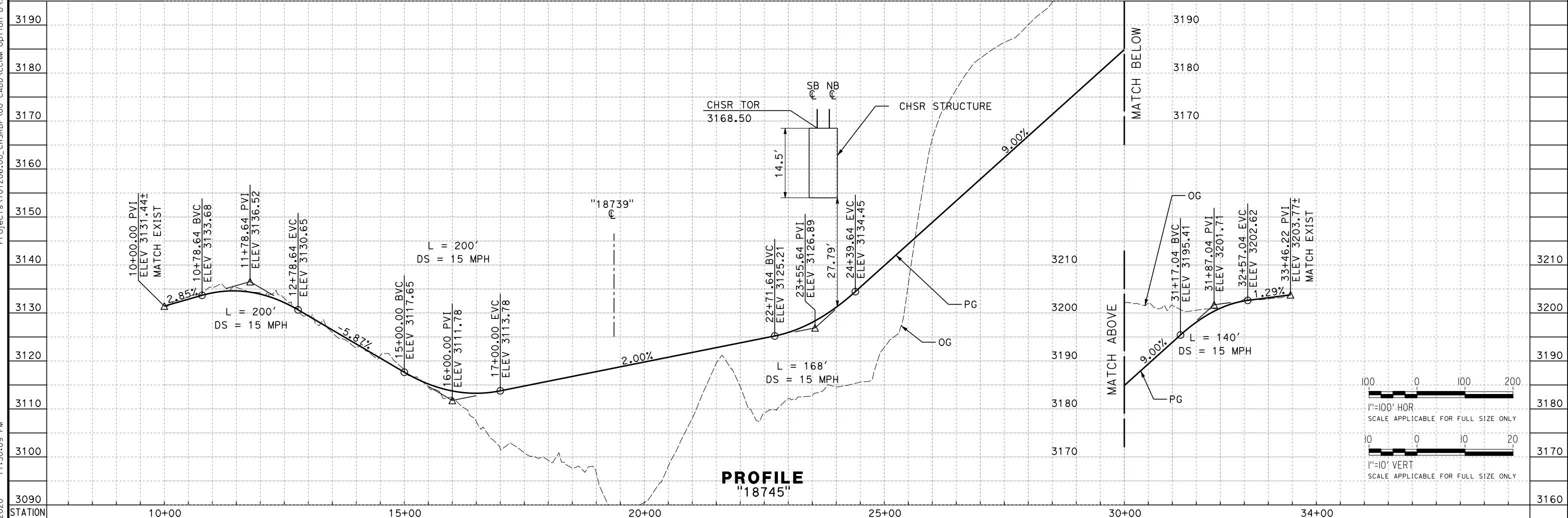

PROFILE
"18745"

Projects\701206.00_CHSRBP\00_CADD\CCNM_Option D\Sheets\CV\BP-CV-R1616
 11:50:09 PM
 1/22/2020
 andrew.carson@tylin.com

REV	DATE	BY	CHK	APP	DESCRIPTION

DESIGNED BY
A. CARSON
 DRAWN BY
A. CARSON
 CHECKED BY
D. HOLMAN
 IN CHARGE
G. CAMPBELL
 DATE
01/24/2020

**RECORD
 PECD
 SUBMITTAL**

**NOT FOR
 CONSTRUCTION**



CALIFORNIA HIGH-SPEED RAIL PROJECT
BAKERSFIELD TO PALMDALE
 REFINED CCNM DESIGN OPTION
 ROADWAY
 ACCESS ROAD "18745"
 PLAN AND PROFILE

CONTRACT NO.
HSR13-44
 DRAWING NO.
CV-R1616
 SCALE
AS SHOWN
 SHEET NO.

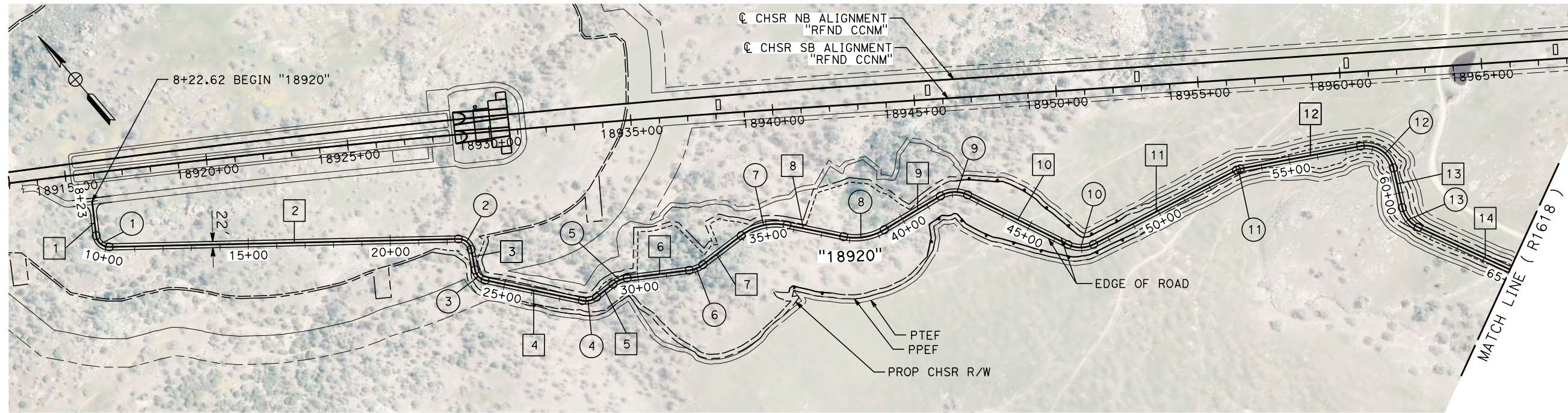

PLAN

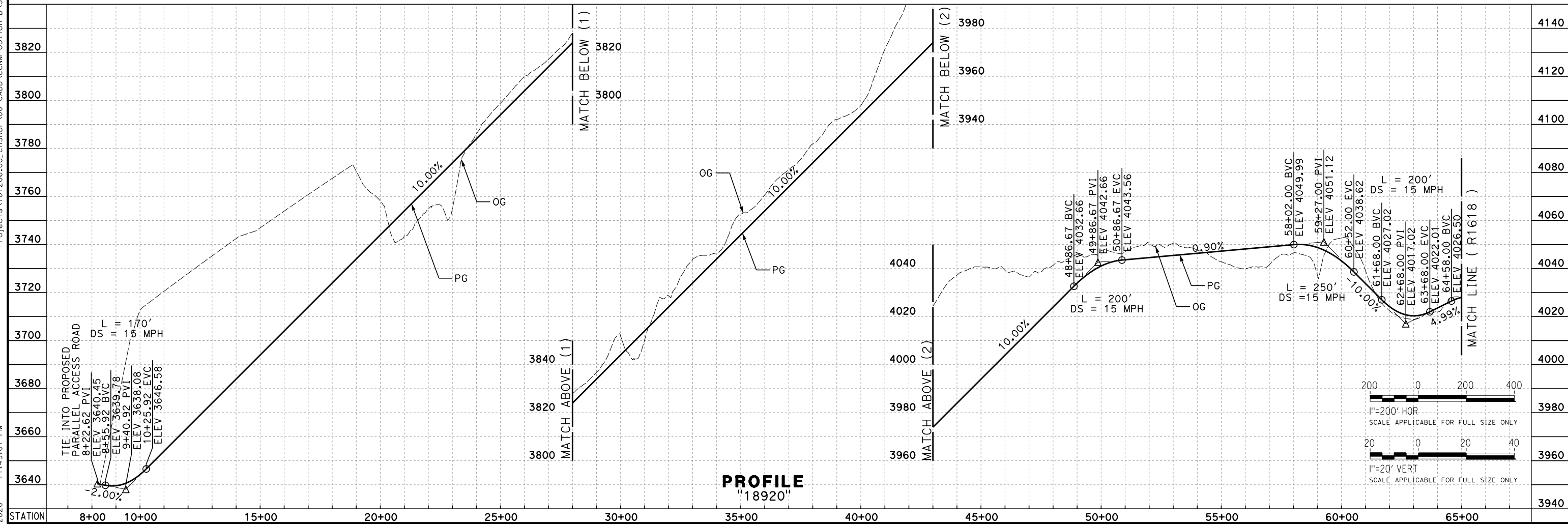

PROFILE
"18920"

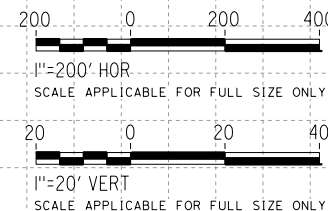

Projects\701206.00_CHSRBP\00_CADD\CCNM Option D\Sheets\CV\BP-CV-R1617
 11:49:07 PM
 1/22/2020
 andrew.carson@tylin.com

REV	DATE	BY	CHK	APP	DESCRIPTION

DESIGNED BY
A. CARSON
 DRAWN BY
A. CARSON
 CHECKED BY
D. HOLMAN
 IN CHARGE
G. CAMPBELL
 DATE
01/24/2020

**RECORD
PEPD
SUBMITTAL**

**NOT FOR
CONSTRUCTION**



CALIFORNIA HIGH-SPEED RAIL PROJECT
BAKERSFIELD TO PALMDALE
 REFINED CCNM DESIGN OPTION
 ROADWAY
 ACCESS ROAD "18920"
 PLAN AND PROFILE - SHEET 1 OF 3

CONTRACT NO.
HSR13-44
 DRAWING NO.
CV-R1617
 SCALE
AS SHOWN
 SHEET NO.

Projects\701206.00_CHSRBP\00_CADD\CCNM_Option D\Sheets\CV\BP-CV-R1618
 1/22/2020 11:49:07 PM
 andrew.carson@tylin.com

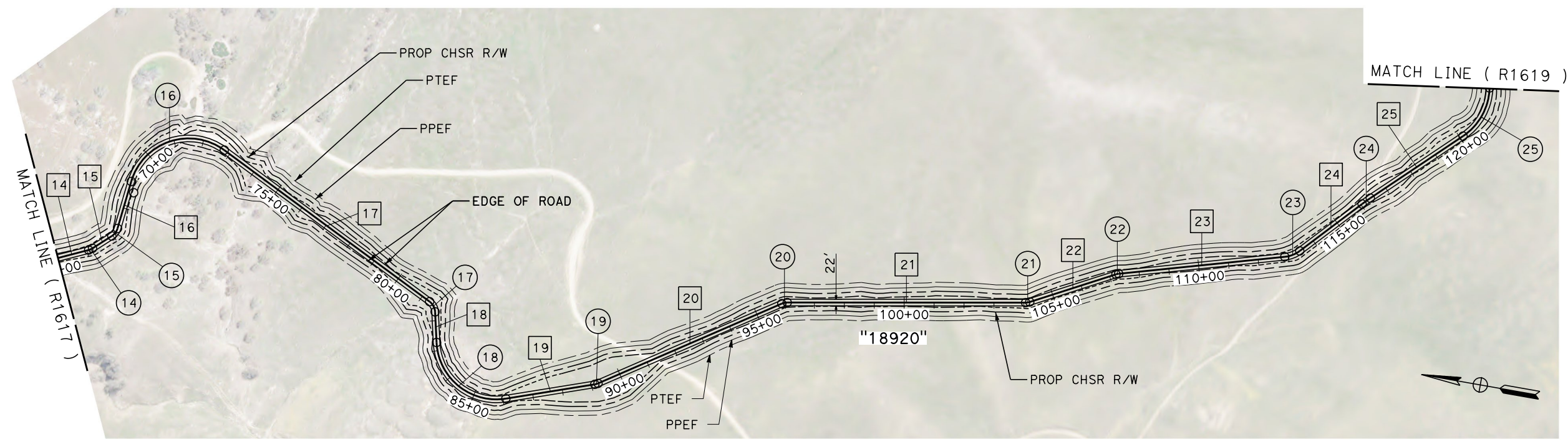

PLAN

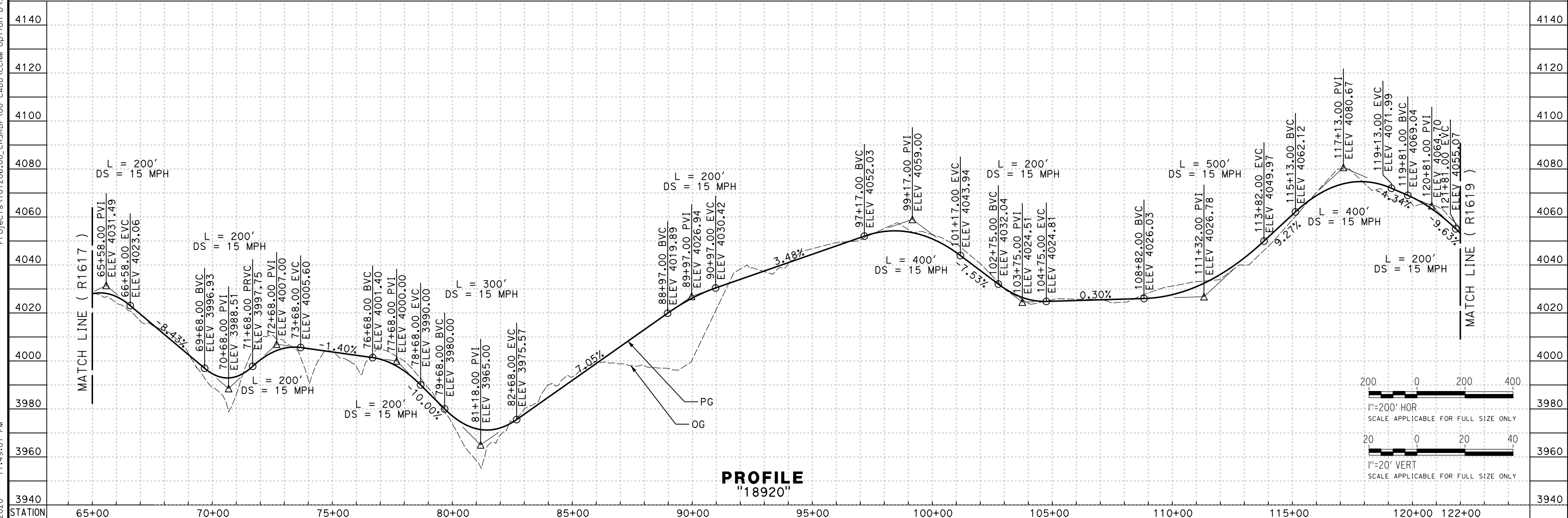

PROFILE
"18920"

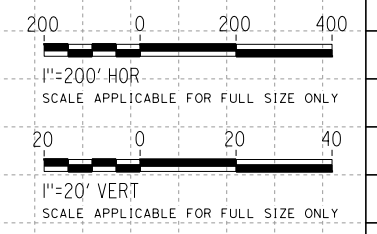

REV	DATE	BY	CHK	APP	DESCRIPTION

DESIGNED BY
A. CARSON
 DRAWN BY
A. CARSON
 CHECKED BY
D. HOLMAN
 IN CHARGE
G. CAMPBELL
 DATE
01/24/2020

**RECORD
PEPD
SUBMITTAL**

**NOT FOR
CONSTRUCTION**



CALIFORNIA HIGH-SPEED RAIL PROJECT
BAKERSFIELD TO PALMDALE
 REFINED CCNM DESIGN OPTION
 ROADWAY
 ACCESS ROAD "18920"
 PLAN AND PROFILE - SHEET 2 OF 3

CONTRACT NO.
HSR13-44
 DRAWING NO.
CV-R1618
 SCALE
AS SHOWN
 SHEET NO.

Projects\701206.00_CHSRBP\00_CADD\CCNM_Option D\Sheets\CV\BP-CV-R1619
 1/22/2020 11:45:56 PM andrew.carson@tylin.com

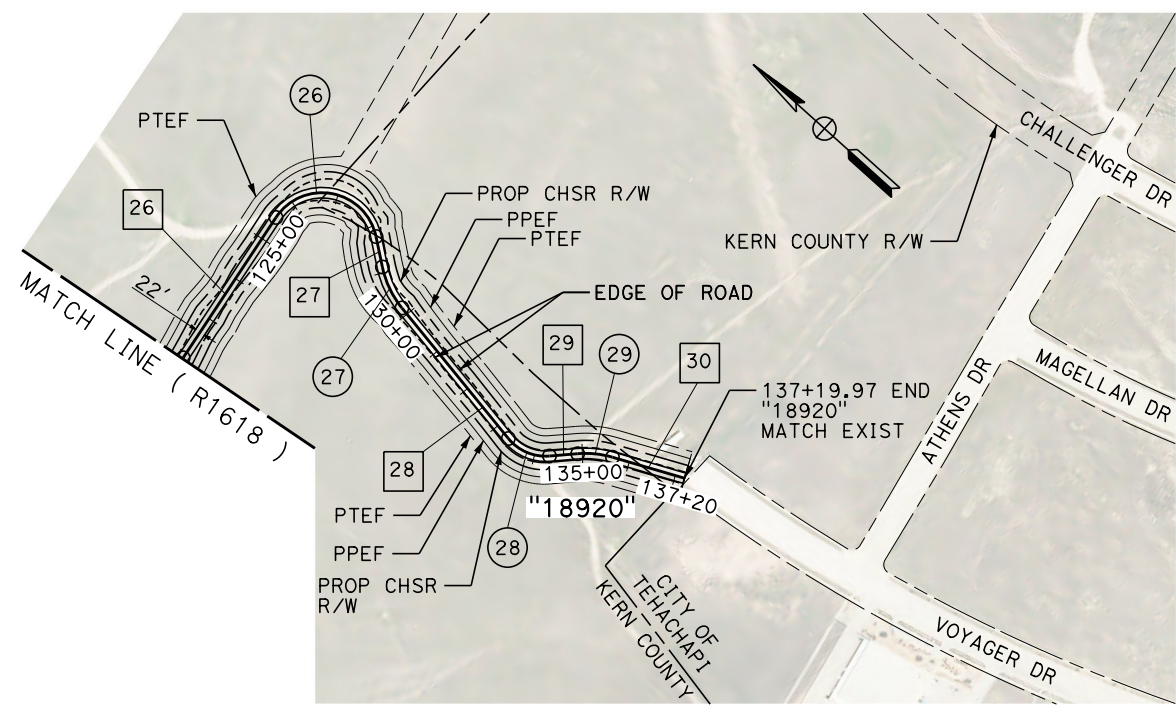

PLAN

LINE DATA		
No.	BEARING	DISTANCE
1	S 33°51'22" W	121.63'
2	S 50°36'50" E	1229.14'
3	S 30°07'26" W	73.73'
4	S 37°27'46" E	349.75'
5	S 87°45'35" E	74.64'
6	S 56°28'40" E	220.34'
7	S 86°35'11" E	169.39'
8	S 37°45'50" E	203.38'
9	S 80°15'54" E	230.40'
10	S 22°57'05" E	393.63'
11	S 76°45'59" E	566.94'
12	S 59°57'10" E	431.17'
13	S 28°07'28" W	143.28'
14	S 24°35'56" E	461.65'
15	S 42°28'09" E	76.49'
16	S 83°42'29" E	163.62'
17	S 26°26'57" W	852.98'
18	S 77°16'58" W	102.34'
19	S 19°07'30" E	301.03'
20	S 33°27'19" E	669.53'
21	S 9°57'21" E	796.71'
22	S 27°46'12" E	302.40'
23	S 15°49'20" E	557.98'
24	S 46°59'33" E	260.76'
25	S 43°46'59" E	372.94'
26	N 81°30'37" E	350.60'
27	S 36°11'56" W	64.80'
28	S 8°50'40" W	351.01'
29	S 46°40'51" E	59.00'
30	S 25°43'29" E	156.43'

CURVE DATA				
No.	R	Δ	T	L
1	45.00'	84°28'11"	40.85'	66.34'
2	45.00'	80°44'16"	38.26'	63.41'
3	45.00'	67°35'12"	30.12'	53.08'
4	60.00'	50°17'49"	28.17'	52.67'
5	100.00'	31°16'55"	28.00'	54.60'
6	100.00'	30°06'31"	26.90'	52.55'
7	200.00'	48°49'21"	90.77'	170.42'
8	200.00'	42°30'04"	77.78'	148.36'
9	100.00'	57°18'50"	54.65'	100.03'
10	100.00'	53°48'54"	50.75'	93.92'
11	45.00'	16°48'50"	6.65'	13.21'
12	100.00'	88°04'38"	96.70'	153.72'
13	100.00'	52°43'24"	49.56'	92.02'
14	45.00'	17°52'13"	7.06'	14.04'
15	45.00'	41°14'20"	16.93'	32.39'
16	200.00'	110°09'27"	286.47'	384.52'
17	45.00'	50°50'01"	21.38'	39.92'
18	200.00'	96°24'28"	223.72'	336.53'
19	45.00'	14°19'49"	5.66'	11.25'
20	45.00'	23°29'58"	9.36'	18.46'
21	45.00'	17°48'51"	7.05'	13.99'
22	45.00'	11°56'53"	4.71'	9.38'
23	100.00'	31°10'13"	27.69'	54.40'
24	600.00'	3°12'34"	16.81'	33.61'
25	200.00'	54°42'25"	103.46'	190.96'
26	115.00'	134°41'19"	275.52'	270.34'
27	200.00'	27°21'17"	48.67'	95.49'
28	100.00'	55°31'30"	52.64'	96.91'
29	200.00'	20°57'21"	36.99'	73.15'

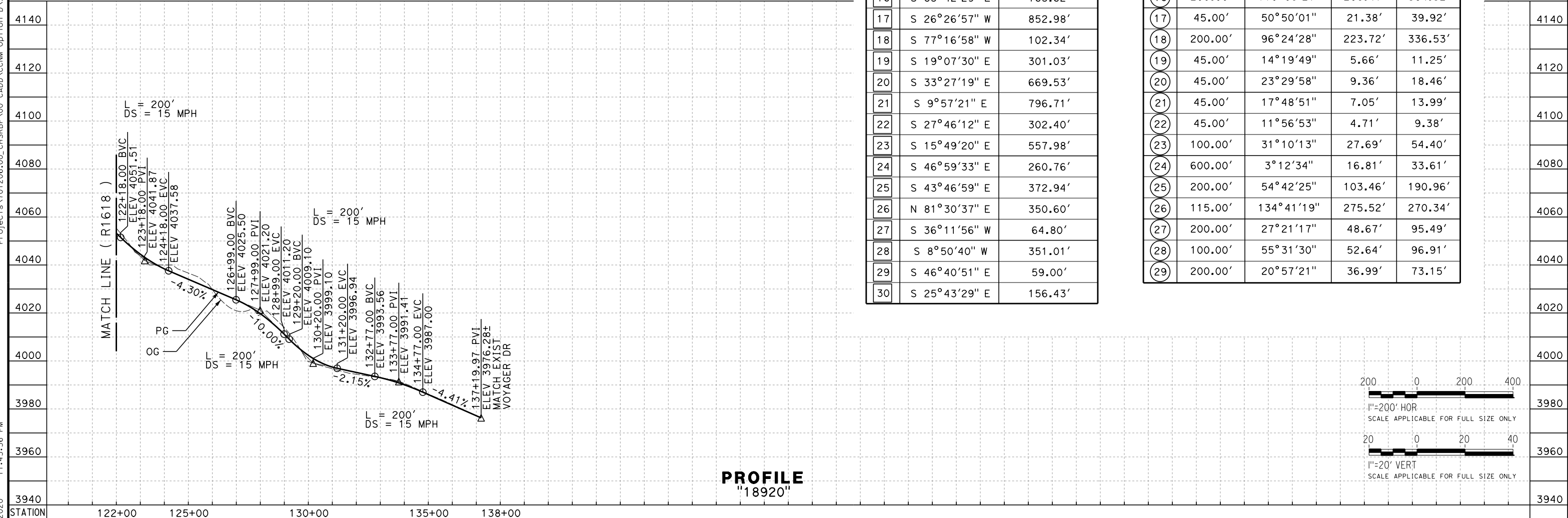

PROFILE
"18920"

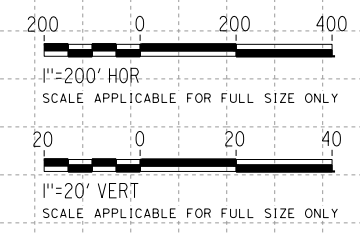

REV	DATE	BY	CHK	APP	DESCRIPTION

DESIGNED BY
A. CARSON
 DRAWN BY
A. CARSON
 CHECKED BY
D. HOLMAN
 IN CHARGE
G. CAMPBELL
 DATE
01/24/2020

**RECORD
PEPD
SUBMITTAL**

**NOT FOR
CONSTRUCTION**

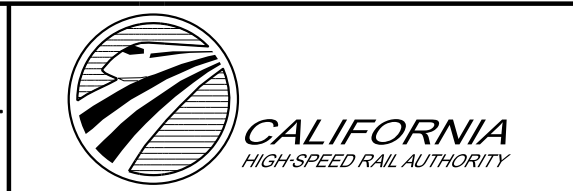

CALIFORNIA HIGH-SPEED RAIL PROJECT
BAKERSFIELD TO PALMDALE
 REFINED CCNM DESIGN OPTION
 ROADWAY
 ACCESS ROAD "18920"
 PLAN AND PROFILE - SHEET 3 OF 3

CONTRACT NO.
HSR13-44
 DRAWING NO.
CV-R1619
 SCALE
AS SHOWN
 SHEET NO.

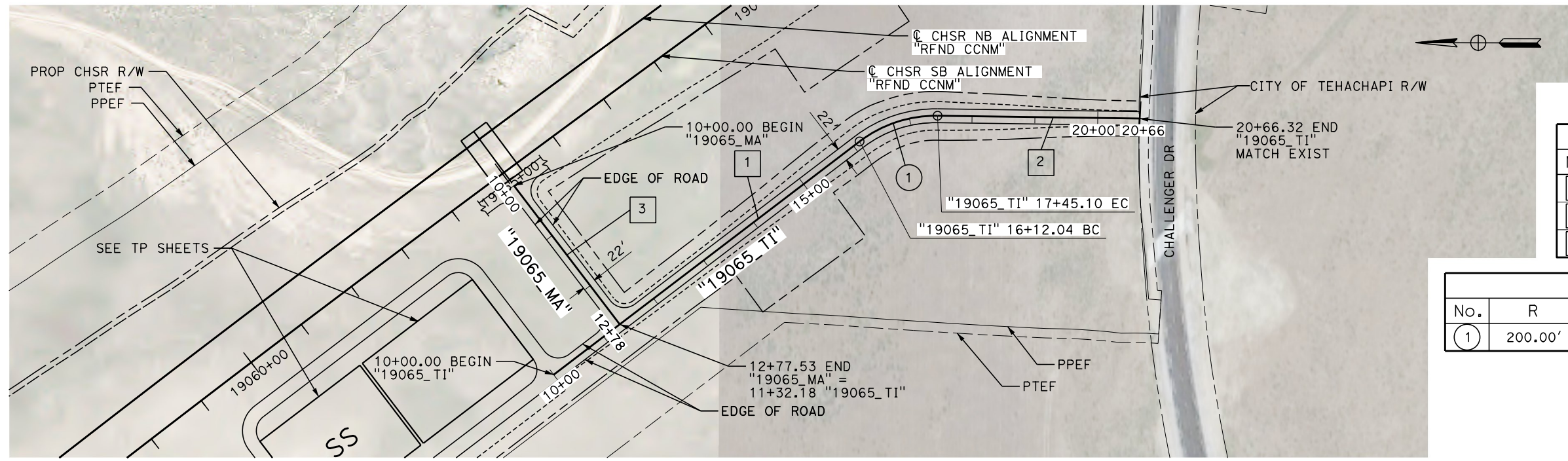

LINE DATA		
No.	BEARING	DISTANCE
1	S 37°28'28" E	612.04'
2	S 0°38'43" W	321.22'
3	S 52°31'32" W	277.53'

CURVE DATA				
No.	R	Δ	T	L
1	200.00'	38°07'11"	69.10'	133.06'

PLAN

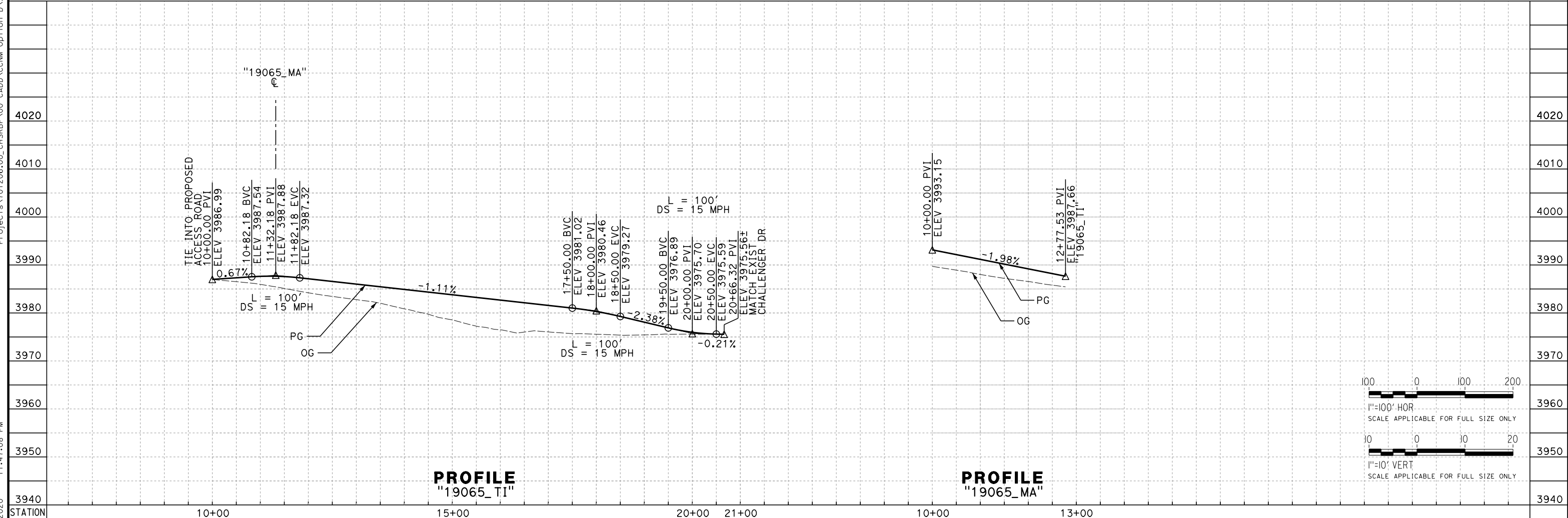

PROFILE
"19065_TI"

PROFILE
"19065_MA"

REV	DATE	BY	CHK	APP	DESCRIPTION

DESIGNED BY
A. CARSON
DRAWN BY
A. CARSON
CHECKED BY
D. HOLMAN
IN CHARGE
G. CAMPBELL
DATE
01/24/2020

**RECORD
PEPD
SUBMITTAL**

**NOT FOR
CONSTRUCTION**



CALIFORNIA HIGH-SPEED RAIL PROJECT
BAKERSFIELD TO PALMDALE
REFINED CCNM DESIGN OPTION
ROADWAY
ACCESS ROAD "19065"
PLAN AND PROFILE

CONTRACT NO.
HSR13-44
DRAWING NO.
CV-R1620
SCALE
AS SHOWN
SHEET NO.

Projects\701206_00_CHSRBP\00_CADD\CCNM_Option_D\Sheets\CV\BP-CV-R1620
 1/22/2020 11:47:08 PM
 andrew.carson@tylin.com

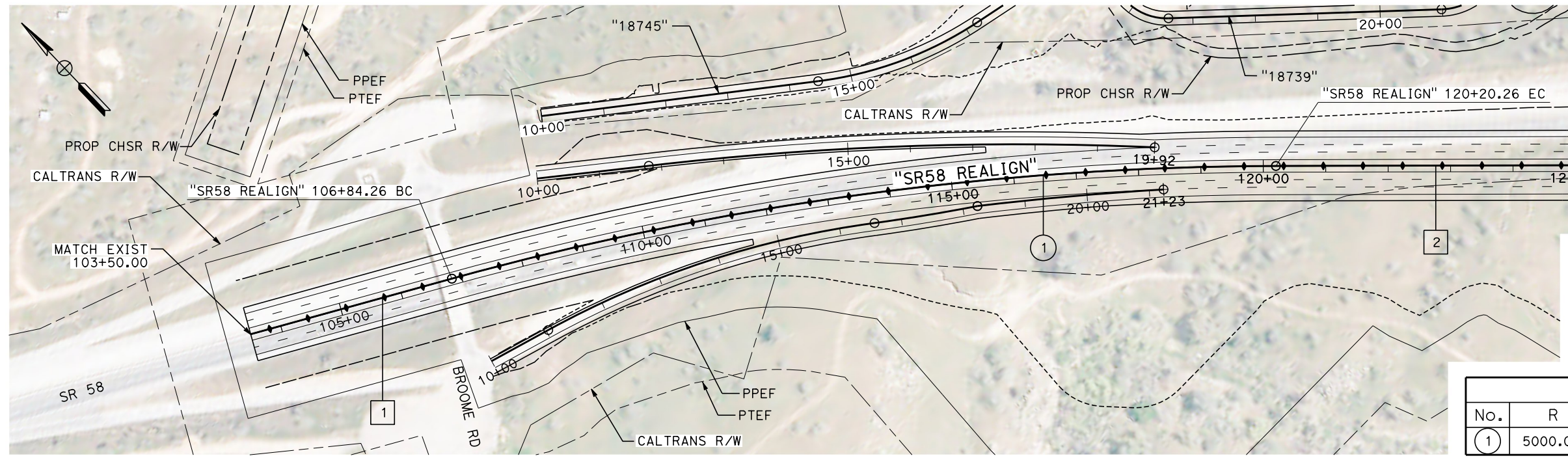

LINE DATA		
No.	BEARING	DISTANCE
1	N 61°49'52" W	334.26'
2	N 46°31'18" W	6020.82'

CURVE DATA				
No.	R	Δ	T	L
1	5000.00'	15°18'34"	672.00'	1336.00'

PLAN

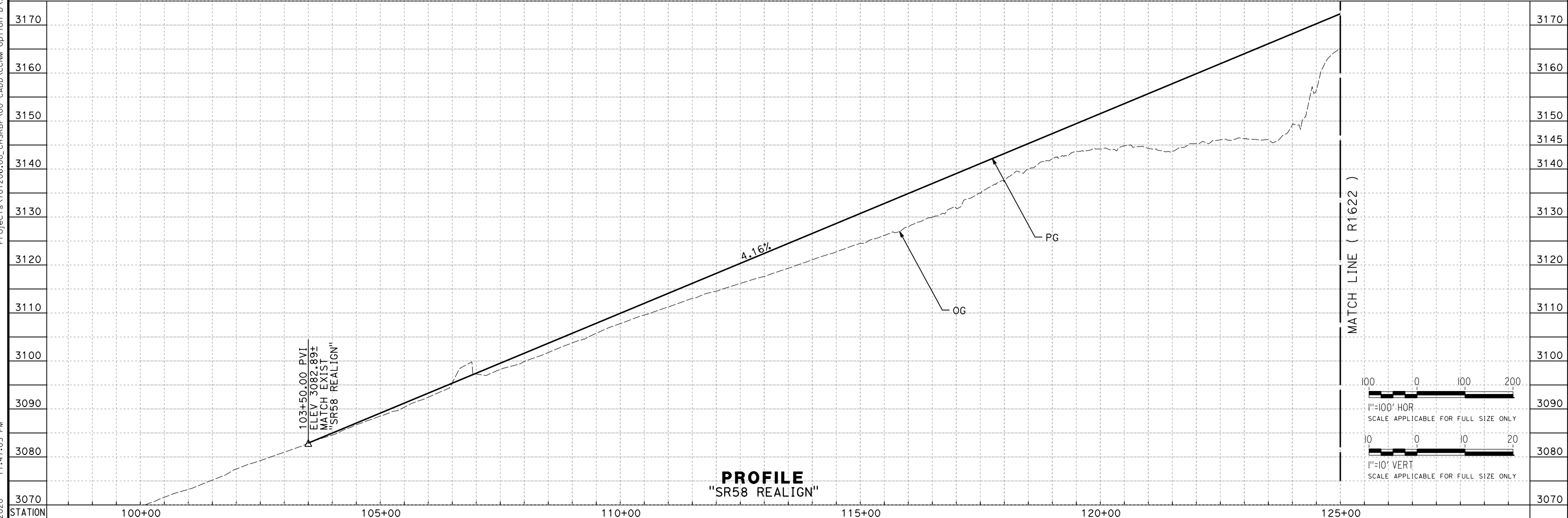

PROFILE
"SR58 REALIGN"

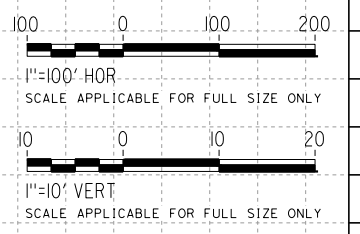

REV	DATE	BY	CHK	APP	DESCRIPTION

DESIGNED BY
A. CARSON
DRAWN BY
A. CARSON
CHECKED BY
D. HOLMAN
IN CHARGE
G. CAMPBELL
DATE
01/24/2020

**RECORD
PEPD
SUBMITTAL**

**NOT FOR
CONSTRUCTION**



CALIFORNIA HIGH-SPEED RAIL PROJECT
BAKERSFIELD TO PALMDALE
REFINED CCNM DESIGN OPTION
ROADWAY
SR 58 REALIGNMENT
PLAN AND PROFILE - SHEET 1 OF 4

CONTRACT NO.
HSR13-44
DRAWING NO.
CV-R1621
SCALE
AS SHOWN
SHEET NO.

Projects\T01206.00_CHSRBP\00_CADD\CCNM_Option_D\Sheets\CV\BP-CV-R1621
 1/22/2020 11:47:05 PM
 andrew.carson@tylin.com

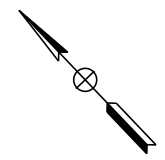
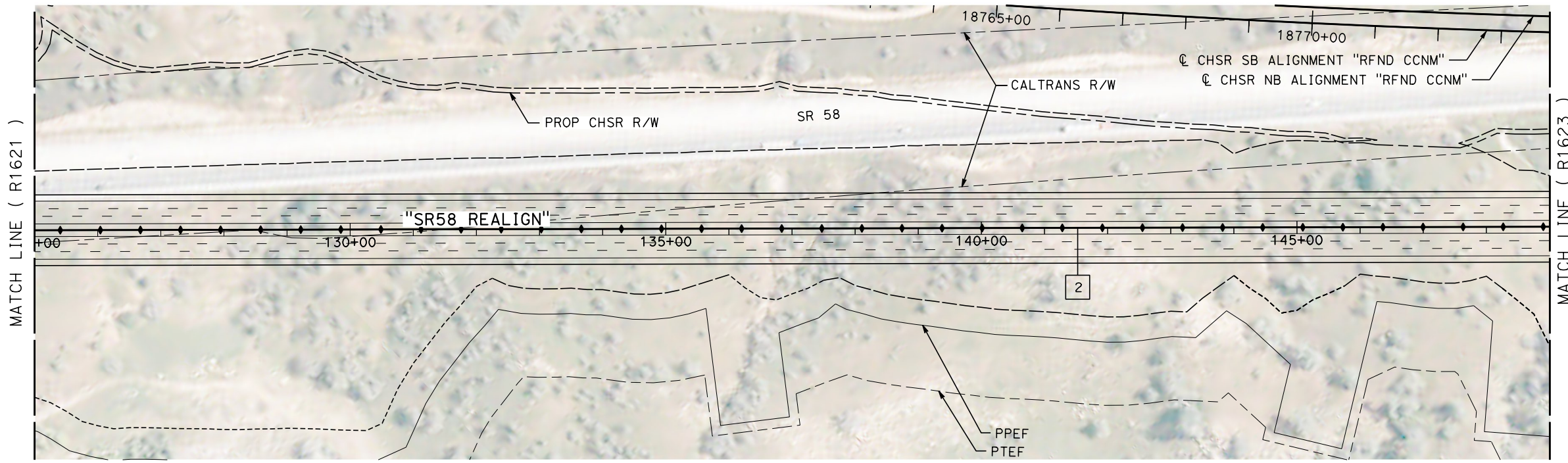

LINE DATA		
No.	BEARING	DISTANCE
2	N 46°31'18" W	6020.82'

PLAN

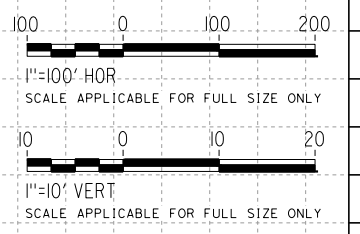
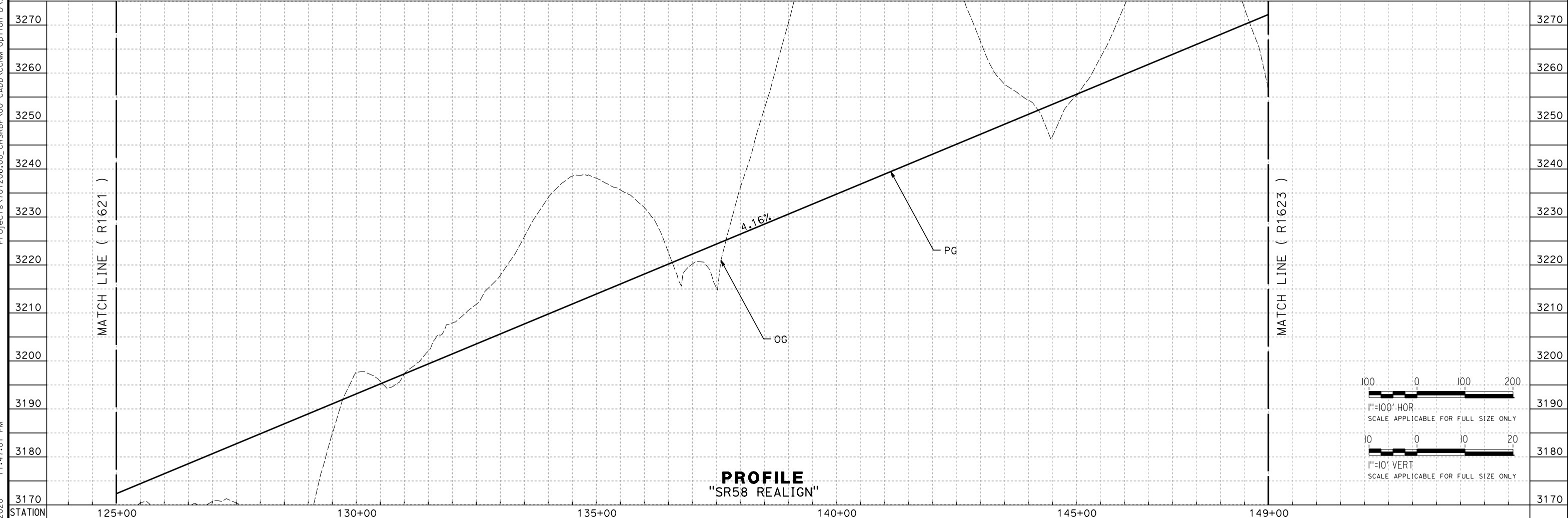

PROFILE
"SR58 REALIGN"

REV	DATE	BY	CHK	APP	DESCRIPTION

DESIGNED BY
A. CARSON
DRAWN BY
A. CARSON
CHECKED BY
D. HOLMAN
IN CHARGE
G. CAMPBELL
DATE
01/24/2020

**RECORD
PEPD
SUBMITTAL**

**NOT FOR
CONSTRUCTION**



CALIFORNIA HIGH-SPEED RAIL PROJECT
BAKERSFIELD TO PALMDALE
REFINED CCNM DESIGN OPTION
ROADWAY
SR 58 REALIGNMENT
PLAN AND PROFILE - SHEET 2 OF 4

CONTRACT NO.
HSR13-44
DRAWING NO.
CV-R1622
SCALE
AS SHOWN
SHEET NO.

Projects\T01206\00_CHSRBP\00_CADD\CCNM Option D\Sheets\CV\BP-CV-R1622 1/22/2020 11:47:01 PM andrew.carson@tylin.com

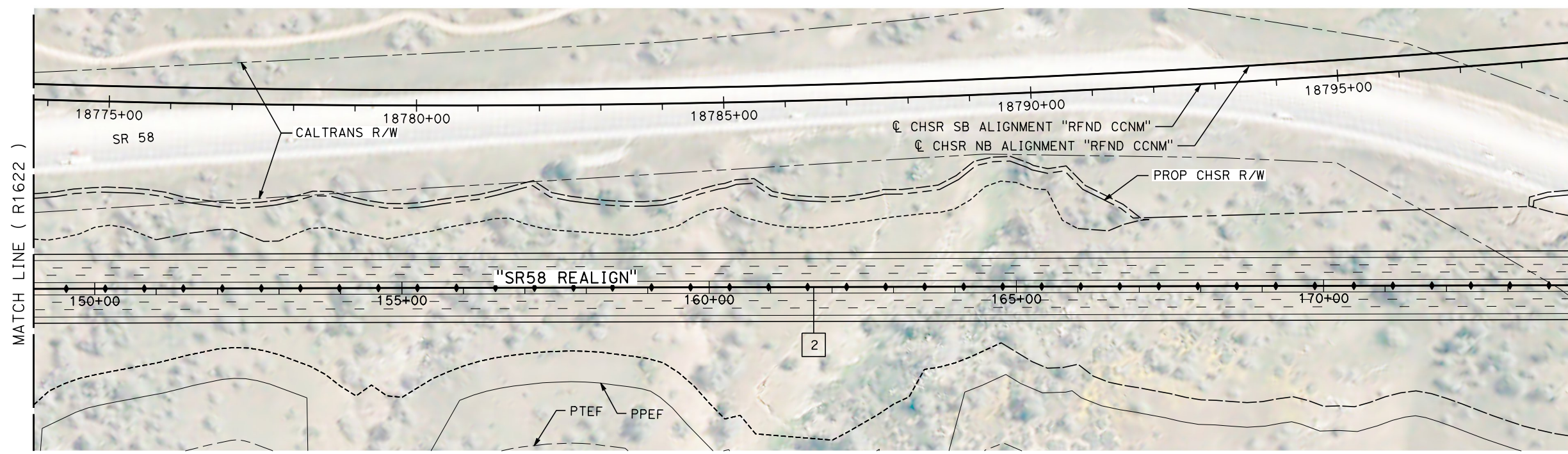

LINE DATA		
No.	BEARING	DISTANCE
2	N 46°31'18" W	6020.82'

PLAN

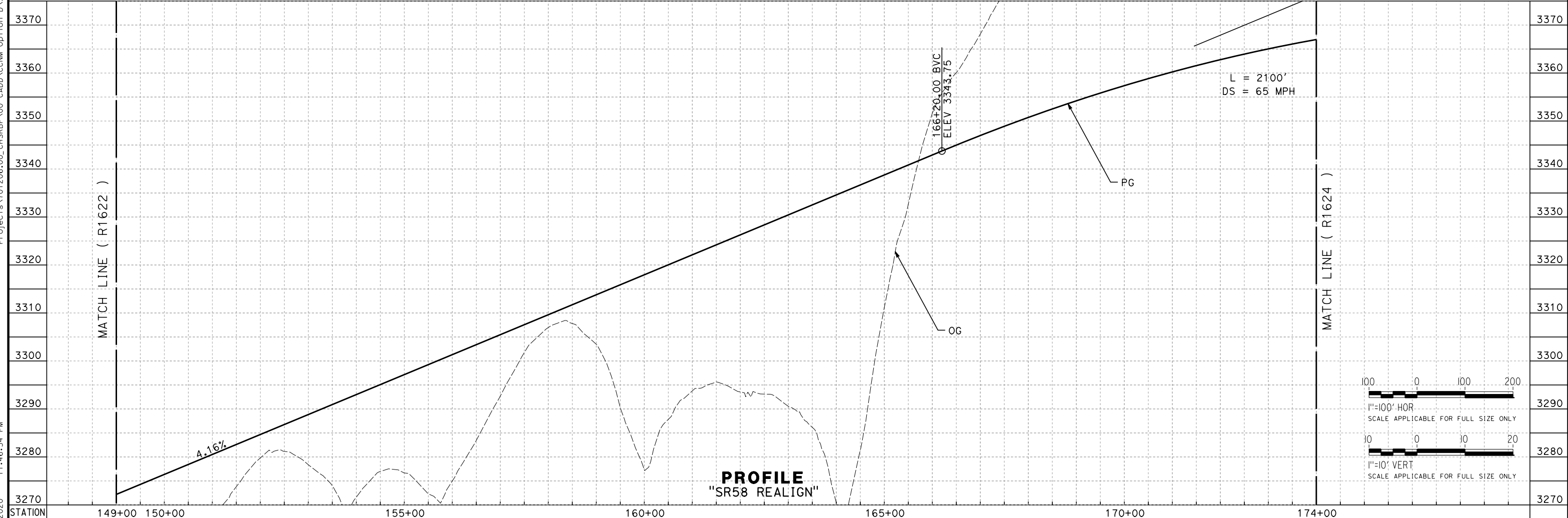

PROFILE
"SR58 REALIGN"

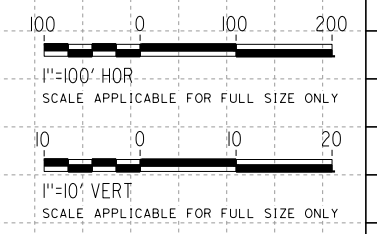

Projects\T01206\00_CHSRBP\00_CADD\CCNM_Option D\Sheets\CV\BP-CV-R1623
 1/22/2020 11:46:54 PM
 andrew.carson@tylin.com

REV	DATE	BY	CHK	APP	DESCRIPTION

DESIGNED BY
A. CARSON
 DRAWN BY
A. CARSON
 CHECKED BY
D. HOLMAN
 IN CHARGE
G. CAMPBELL
 DATE
01/24/2020

**RECORD
PEPD
SUBMITTAL**

**NOT FOR
CONSTRUCTION**



CALIFORNIA HIGH-SPEED RAIL PROJECT
BAKERSFIELD TO PALMDALE
 REFINED CCNM DESIGN OPTION
 ROADWAY
 SR 58 REALIGNMENT
 PLAN AND PROFILE - SHEET 3 OF 4

CONTRACT NO.
HSR13-44
 DRAWING NO.
CV-R1623
 SCALE
AS SHOWN
 SHEET NO.

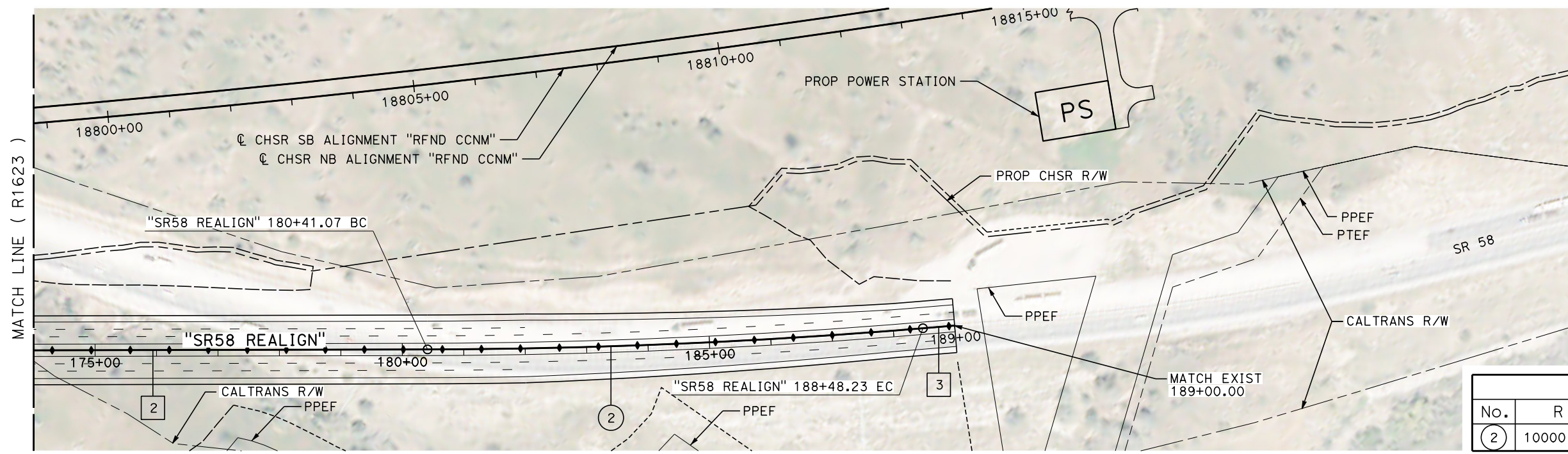

LINE DATA		
No.	BEARING	DISTANCE
2	N 46°31'18" W	6020.82'
3	N 51°08'47" W	51.77'

CURVE DATA				
No.	R	Δ	T	L
2	10000.00'	041°37'29"	403.80'	807.16'

PLAN

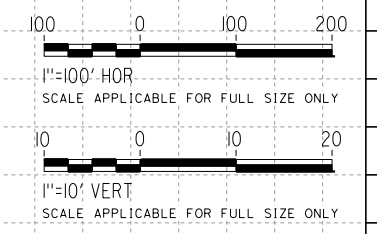
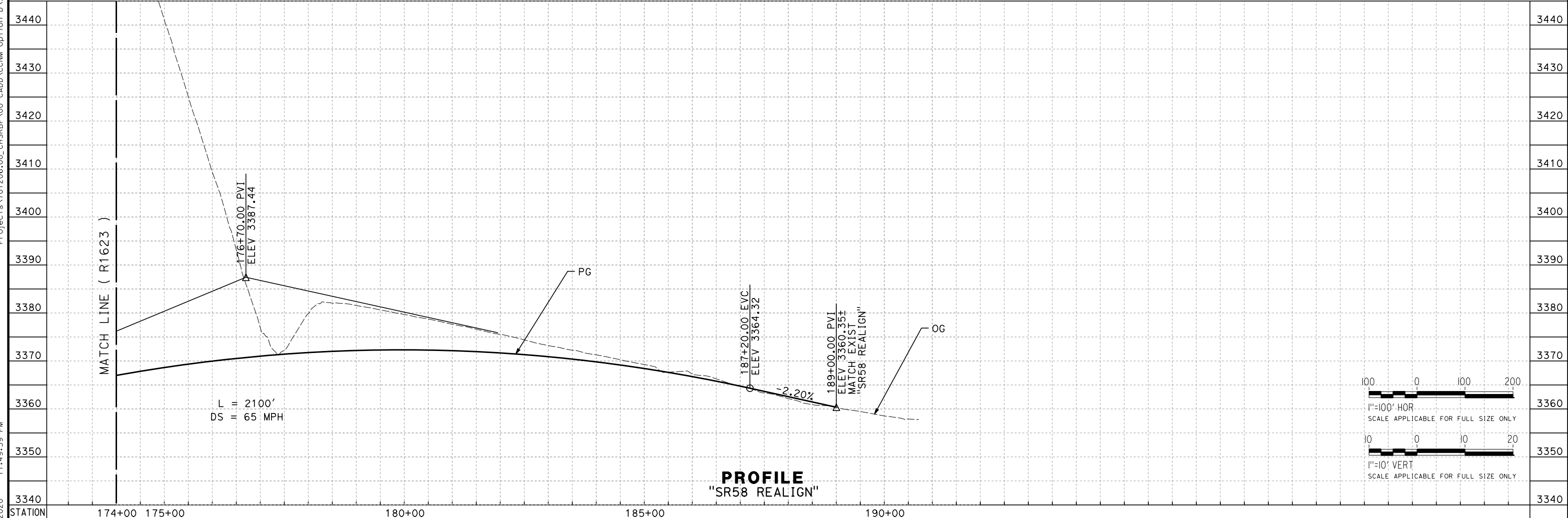

PROFILE
"SR58 REALIGN"

REV	DATE	BY	CHK	APP	DESCRIPTION

DESIGNED BY
A. CARSON
DRAWN BY
A. CARSON
CHECKED BY
D. HOLMAN
IN CHARGE
G. CAMPBELL
DATE
01/24/2020

**RECORD
PEPD
SUBMITTAL**

**NOT FOR
CONSTRUCTION**



CALIFORNIA HIGH-SPEED RAIL PROJECT
BAKERSFIELD TO PALMDALE
REFINED CCNM DESIGN OPTION
ROADWAY
SR 58 REALIGNMENT
PLAN AND PROFILE - SHEET 4 OF 4

CONTRACT NO.
HSR13-44
DRAWING NO.
CV-R1624
SCALE
AS SHOWN
SHEET NO.

Projects\701206.00_CHSRBP\00_CADD\CCNM_Option_D\Sheets\CV\BP-CV-R1624
 1/22/2020 11:49:39 PM
 andrew.carson@tylin.com

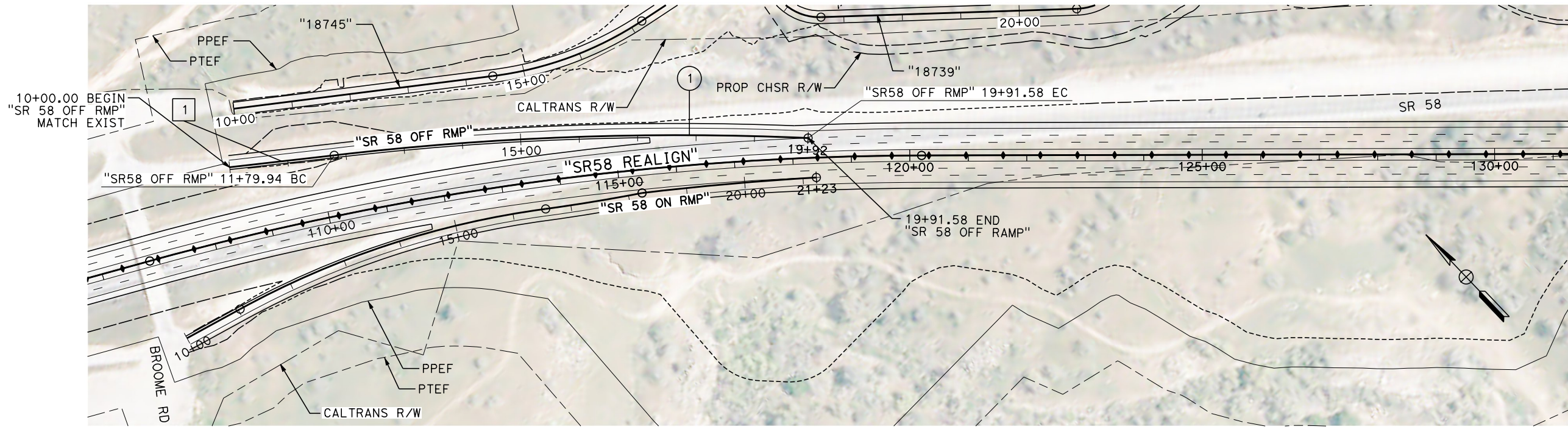

PLAN

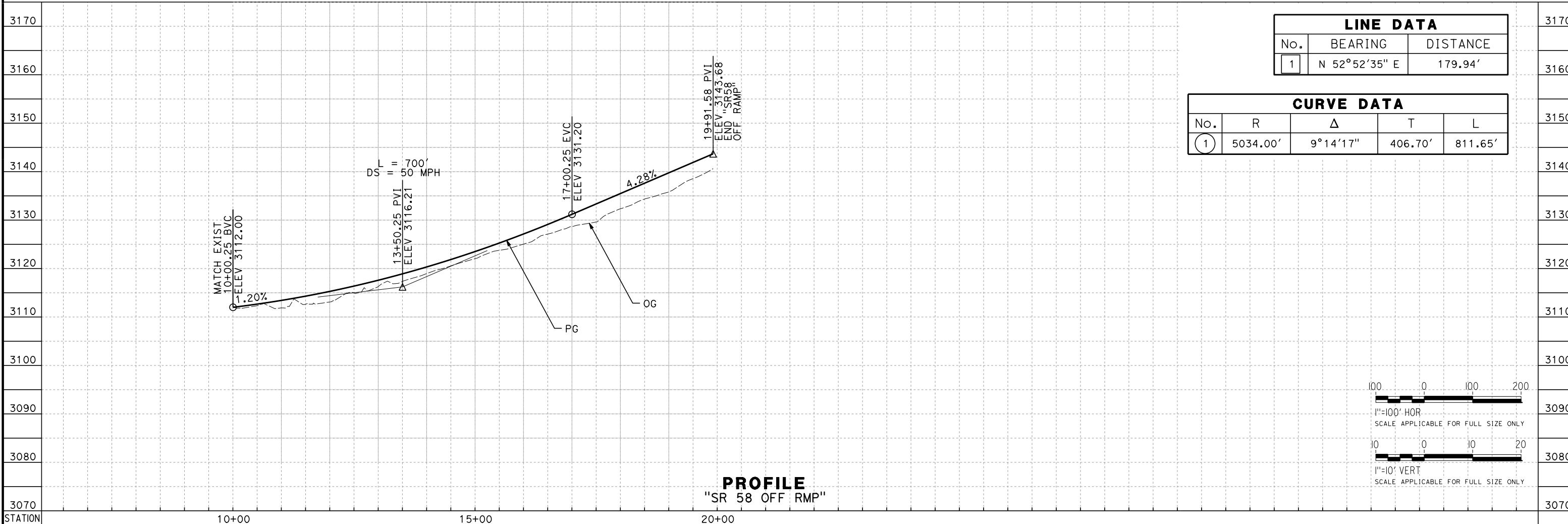

PROFILE
"SR 58 OFF RMP"

LINE DATA		
No.	BEARING	DISTANCE
1	N 52°52'35" E	179.94'

CURVE DATA				
No.	R	Δ	T	L
1	5034.00'	9°14'17"	406.70'	811.65'

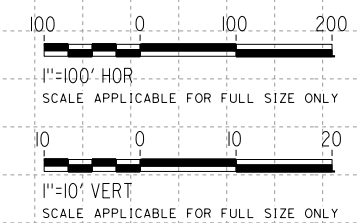

REV	DATE	BY	CHK	APP	DESCRIPTION

DESIGNED BY
A. CARSON
DRAWN BY
A. CARSON
CHECKED BY
D. HOLMAN
IN CHARGE
G. CAMPBELL
DATE
01/24/2020

**RECORD
PEPD
SUBMITTAL**

**NOT FOR
CONSTRUCTION**



CALIFORNIA HIGH-SPEED RAIL PROJECT
BAKERSFIELD TO PALMDALE
REFINED CCNM DESIGN OPTION
ROADWAY
SR 58 REALIGNMENT OFF-RAMP
PLAN AND PROFILE

CONTRACT NO.
HSR13-44
DRAWING NO.
CV-R1625
SCALE
AS SHOWN
SHEET NO.

Projects\701206.00_CHSRBP\00_CADD\CCNM Option D\Sheets\CV\BP-CV-R1625 11:56:33 PM 1/22/2020 andrew.carson@tylin.com

Projects\701206.00_CHSRBP\00_CADD\CCNM_Option D\Sheets\CV\BP-CV-R1626
 1/22/2020 11:48:36 PM
 andrew.carson@tylin.com

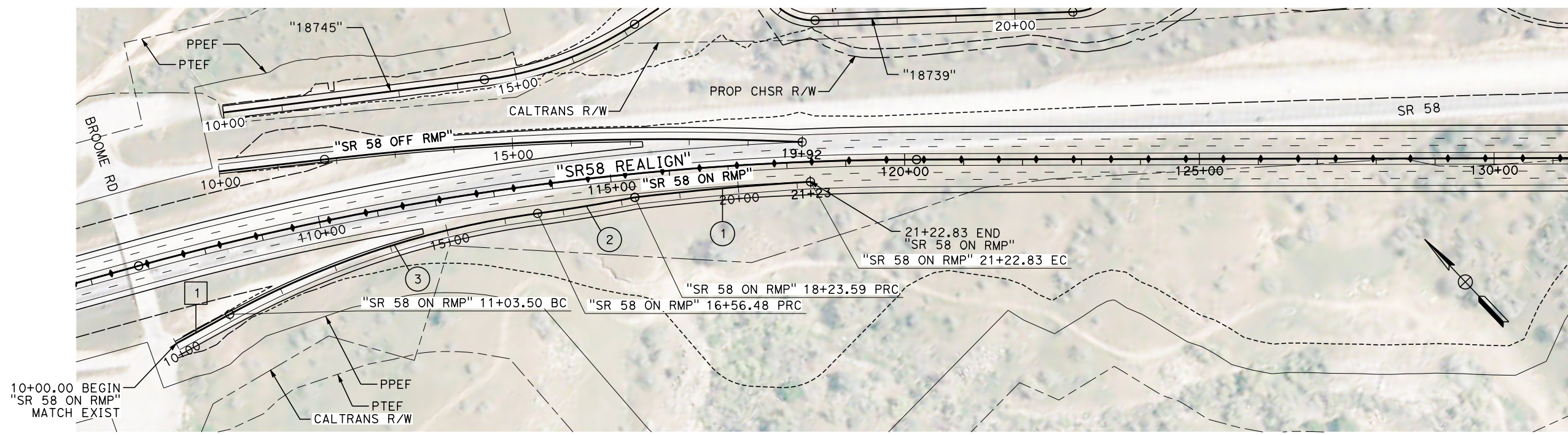

PLAN

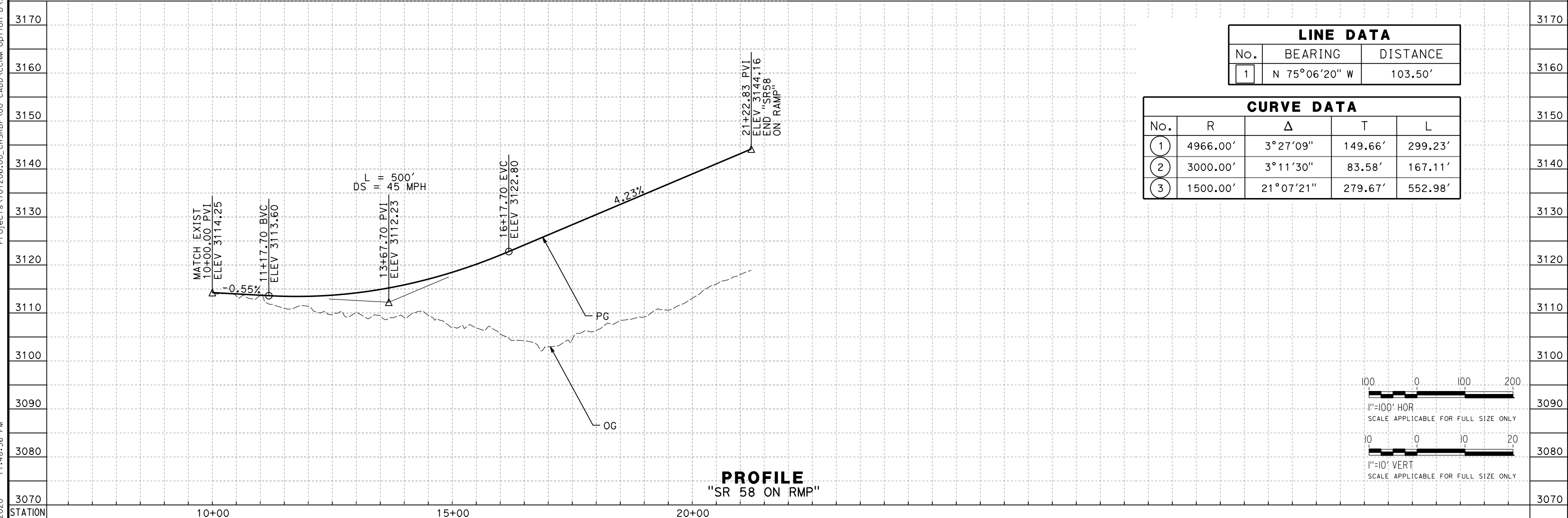

PROFILE
"SR 58 ON RMP"

LINE DATA		
No.	BEARING	DISTANCE
1	N 75°06'20" W	103.50'

CURVE DATA				
No.	R	Δ	T	L
1	4966.00'	3°27'09"	149.66'	299.23'
2	3000.00'	3°11'30"	83.58'	167.11'
3	1500.00'	21°07'21"	279.67'	552.98'

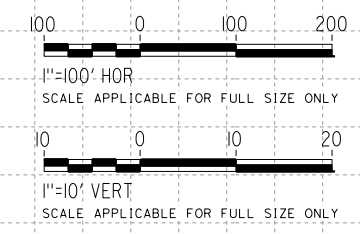

REV	DATE	BY	CHK	APP	DESCRIPTION

DESIGNED BY
A. CARSON
 DRAWN BY
A. CARSON
 CHECKED BY
D. HOLMAN
 IN CHARGE
G. CAMPBELL
 DATE
01/24/2020

**RECORD
PEPD
SUBMITTAL**

**NOT FOR
CONSTRUCTION**



CALIFORNIA HIGH-SPEED RAIL PROJECT
BAKERSFIELD TO PALMDALE
 REFINED CCNM DESIGN OPTION
 ROADWAY
 SR 58 REALIGNMENT ON-RAMP
 PLAN AND PROFILE

CONTRACT NO.
HSR13-44
 DRAWING NO.
CV-R1626
 SCALE
AS SHOWN
 SHEET NO.

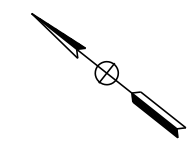
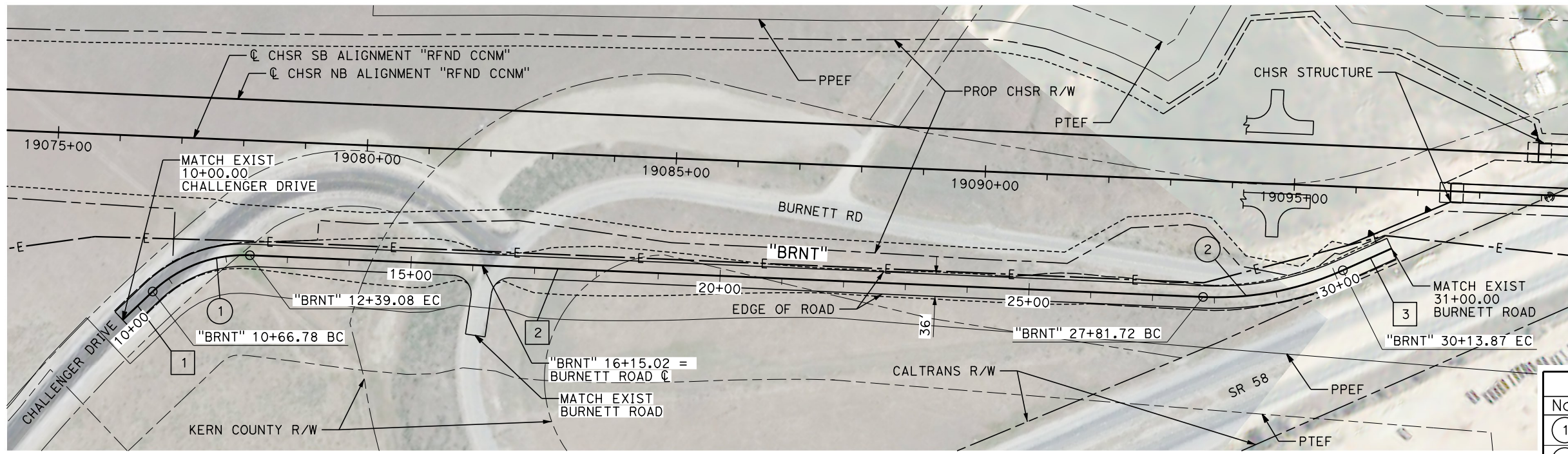

LINE DATA		
No.	BEARING	DISTANCE
1	N 81°51'24" W	66.78'
2	N 33°56'20" W	1542.64'
3	N 62°32'28" W	86.13'

CURVE DATA				
No.	R	Δ	T	L
1	215.00'	45°55'04"	91.08'	172.30'
2	500.00'	26°36'07"	118.21'	232.15'

PLAN

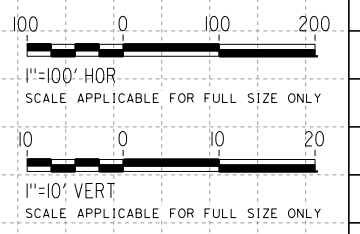
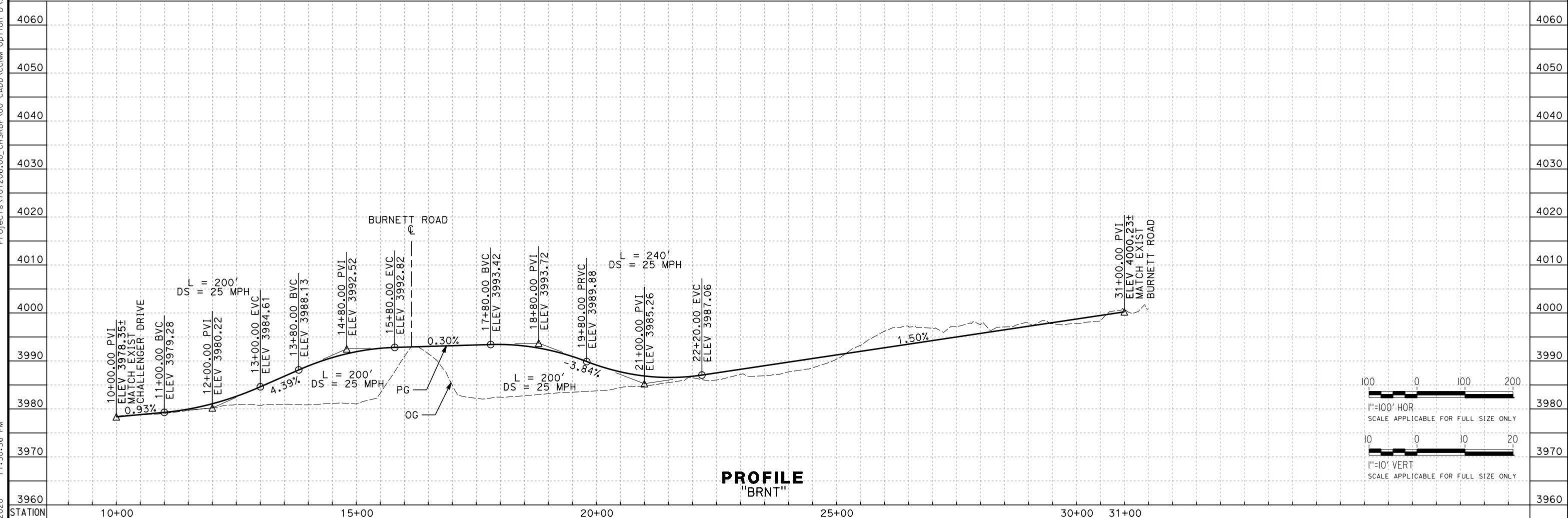

PROFILE
"BRNT"

Projects\701206_00_CHSRBP\00_CADD\CCNM_Option D\Sheets\CV\BP-CV-R1627
 1/22/2020 11:50:36 PM andrew.carson@tylin.com

REV	DATE	BY	CHK	APP	DESCRIPTION

DESIGNED BY
A. CARSON
 DRAWN BY
A. CARSON
 CHECKED BY
D. HOLMAN
 IN CHARGE
G. CAMPBELL
 DATE
01/24/2020

**RECORD
PEPD
SUBMITTAL**

**NOT FOR
CONSTRUCTION**











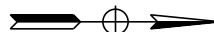



CALIFORNIA HIGH-SPEED RAIL PROJECT
BAKERSFIELD TO PALMDALE
 REFINED CCNM DESIGN OPTION
 ROADWAY
 BURNETT ROAD
 PLAN AND PROFILE

CONTRACT NO.
HSR13-44
 DRAWING NO.
CV-R1627
 SCALE
AS SHOWN
 SHEET NO.

\$USER\$ 1/23/2020 2:42:50 AM \$PENTBLS\$ \$PLTDRVS\$ \$FILE\$

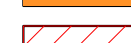
LEGEND

-  NORTH ARROW
-  PROPOSED TEMPORARY ENVIRONMENTAL FOOTPRINT
-  PROPOSED PERMANENT ENVIRONMENTAL FOOTPRINT
-  LIMITS OF EXCAVATION (CUT)
-  LIMITS OF EMBANKMENT (FILL)
-  CONSTRUCTION STAGING / LAYDOWN AREA, ROCK CRUSHING PLANT, OR ROCK CRUSHING & PRECAST OPERATIONS YARD
-  PROPOSED RETAINING WALL
-  PHASE 1
-  PHASE 2
-  PHASE 3
-  CUT AREAS
-  FILL AREAS

GENERAL NOTES

1. DETAILED CONSTRUCTION SEQUENCE FOR GRADE SEPARATIONS IS NOT PROVIDED IN THIS SET OF PLANS. UTILITY RELOCATIONS ARE NOT SHOWN.
2. TRAFFIC DETOURS ARE NOT SHOWN IN THIS SET OF PLANS.
3. LAYDOWN AREAS, STAGING AREAS AND OTHER CONTRACTOR'S FACILITIES ARE INCLUDED IN THIS SET OF PLANS.
4. DETAILED PHASING OF LONG CHSR VIADUCTS ARE NOT SHOWN.
5. LMF (LIGHT MAINTENANCE FACILITY), MOWF (MAINTENANCE OF WAY FACILITY), MOWS (MAINTENANCE OF WAY SIDING), TPF (TRACTION POWER FACILITY), TPS (TRACTION POWER SUBSTATION) MAY BE SHOWN, BUT NOT INCLUDED IN THE SEQUENCING.
6. CONSTRUCTION PHASES WILL OVERLAP AS NEEDED TO REDUCE CONSTRUCTION DURATIONS.
7. DRAINAGE OVERCROSSINGS ALONG THE ALIGNMENTS ARE NOT SHOWN IN THE SEQUENCING PLANS.

ABBREVIATIONS

CHSR	CALIFORNIA HIGH-SPEED RAIL
D&B	DRILL AND BLAST
LMF	LIGHT MAINTENANCE FACILITY
MOWF	MAINTENANCE OF WAY FACILITY
OH	OVERHEAD
RS-WA	RAIL STORAGE & WELDING AREA
SEM	SEQUENTIAL EXCAVATION METHOD
STA	STATION
TPF	TRACTION POWER FACILITY
TPS	TRACTION POWER SUBSTATION
TBM	TUNNEL BORING MACHINE
UP/UC	UNDERPASS / UNDERCROSSING
UPRR	UNION PACIFIC RAILROAD
PPEF	PROPOSED PERMANENT ENVIRONMENTAL FOOTPRINT
PTEF	PROPOSED TEMPORARY ENVIRONMENTAL FOOTPRINT

REV	DATE	BY	CHK	APP	DESCRIPTION

DESIGNED BY
J. TURRELL
 DRAWN BY
B. MOZAFFARIAN
 CHECKED BY
S. LANDOLT
 IN CHARGE
G. CAMPBELL
 DATE
01/24/2020

**RECORD
 PEPD
 SUBMITTAL**

**NOT FOR
 CONSTRUCTION**



CALIFORNIA HIGH-SPEED RAIL PROJECT
BAKERSFIELD TO PALMDALE
 REFINED CCNM DESIGN OPTION
 CONSTRUCTION SEQUENCING GENERAL
 NOTES & LEGEND

CONTRACT NO. HSR13-44
DRAWING NO. CV-10101
SCALE NO SCALE
SHEET NO.

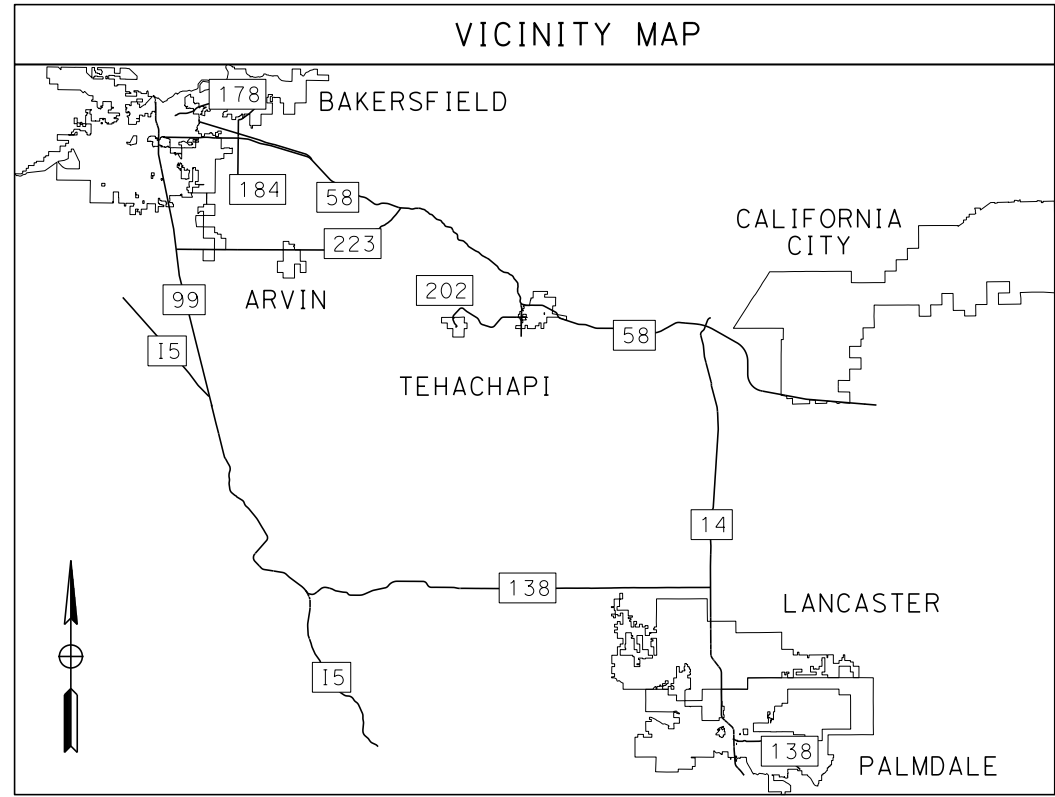
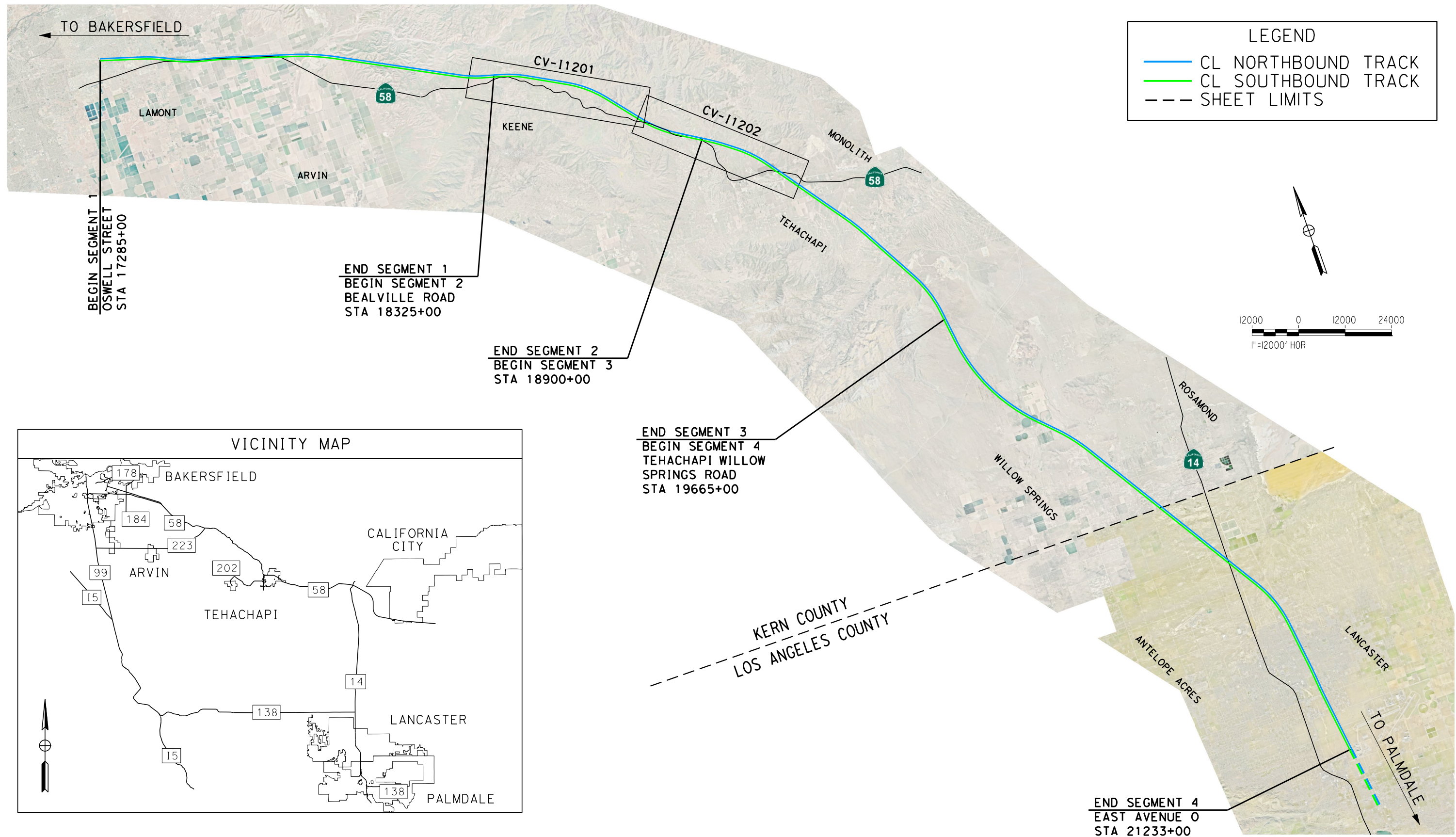

\$USER\$ 1/23/2020 2:43:35 AM \$PENTBL\$ \$PLTDRVS\$ \$FILE\$

REV	DATE	BY	CHK	APP	DESCRIPTION

DESIGNED BY
J. TURRELL
 DRAWN BY
B. MOZAFFARIAN
 CHECKED BY
S. LANDOLT
 IN CHARGE
G. CAMPBELL
 DATE
01/24/2020

**RECORD
 PEPD
 SUBMITTAL**

**NOT FOR
 CONSTRUCTION**



CALIFORNIA HIGH-SPEED RAIL PROJECT
BAKERSFIELD TO PALMDALE
 REFINED CCNM DESIGN OPTION
 CONSTRUCTION SEQUENCING GENERAL
 KEY MAP

CONTRACT NO.
 HSR13-44
 DRAWING NO.
 CV-10102
 SCALE
 AS SHOWN
 SHEET NO.

SEGMENT 2

PHASE 1
"ALL PHASING AT CONTRACTOR'S DISCRETION"

PHASE 2

PHASE 3

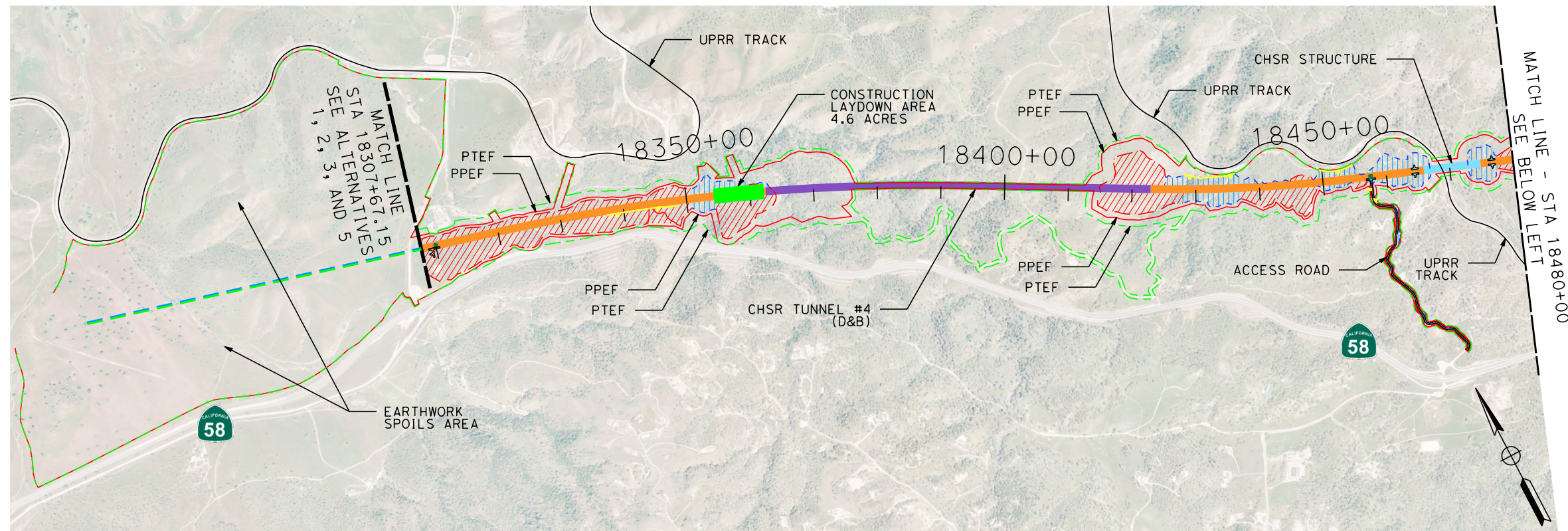

SEGMENT 2

PHASE 1
"ALL PHASING AT CONTRACTOR'S DISCRETION"

PHASE 2

PHASE 3

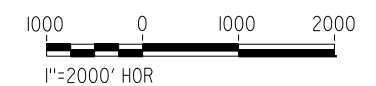
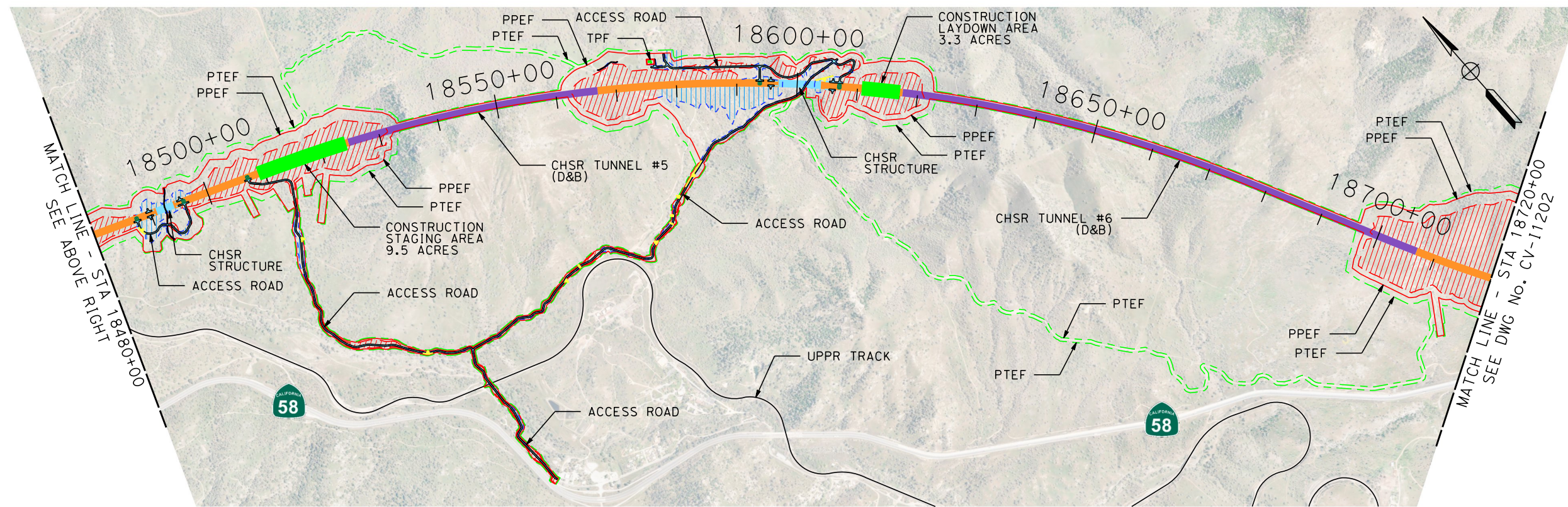

\$USER:\$ 1/23/2020 2:43:40 AM \$PENTBL:\$ \$PLTDRVS:\$ \$FILE:\$

REV	DATE	BY	CHK	APP	DESCRIPTION

DESIGNED BY
J. TURRELL
 DRAWN BY
B. MOZAFFARIAN
 CHECKED BY
S. LANDOLT
 IN CHARGE
G. CAMPBELL
 DATE
01/24/2020

**RECORD
PEPD
SUBMITTAL**

**NOT FOR
CONSTRUCTION**



CALIFORNIA HIGH-SPEED RAIL PROJECT
BAKERSFIELD TO PALMDALE
 REFINED CCNM DESIGN OPTION
 CONSTRUCTION SEQUENCING
 SHEET 1 OF 2

CONTRACT NO.
HSR13-44
 DRAWING NO.
CV-11201
 SCALE
AS SHOWN
 SHEET NO.

SEGMENT 2

PHASE 1
"ALL PHASING AT CONTRACTOR'S DISCRETION"

PHASE 2

PHASE 3

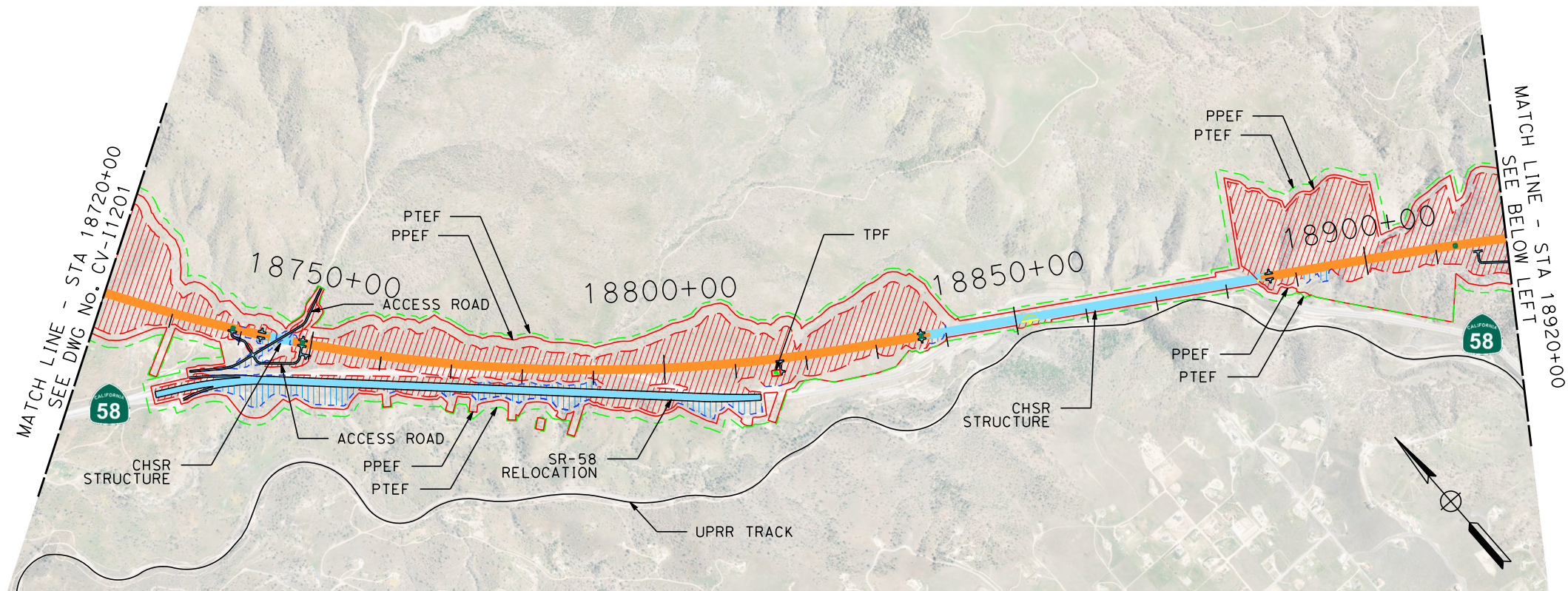

SEGMENT 2

PHASE 1
"ALL PHASING AT CONTRACTOR'S DISCRETION"

PHASE 2

PHASE 3

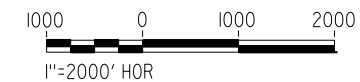
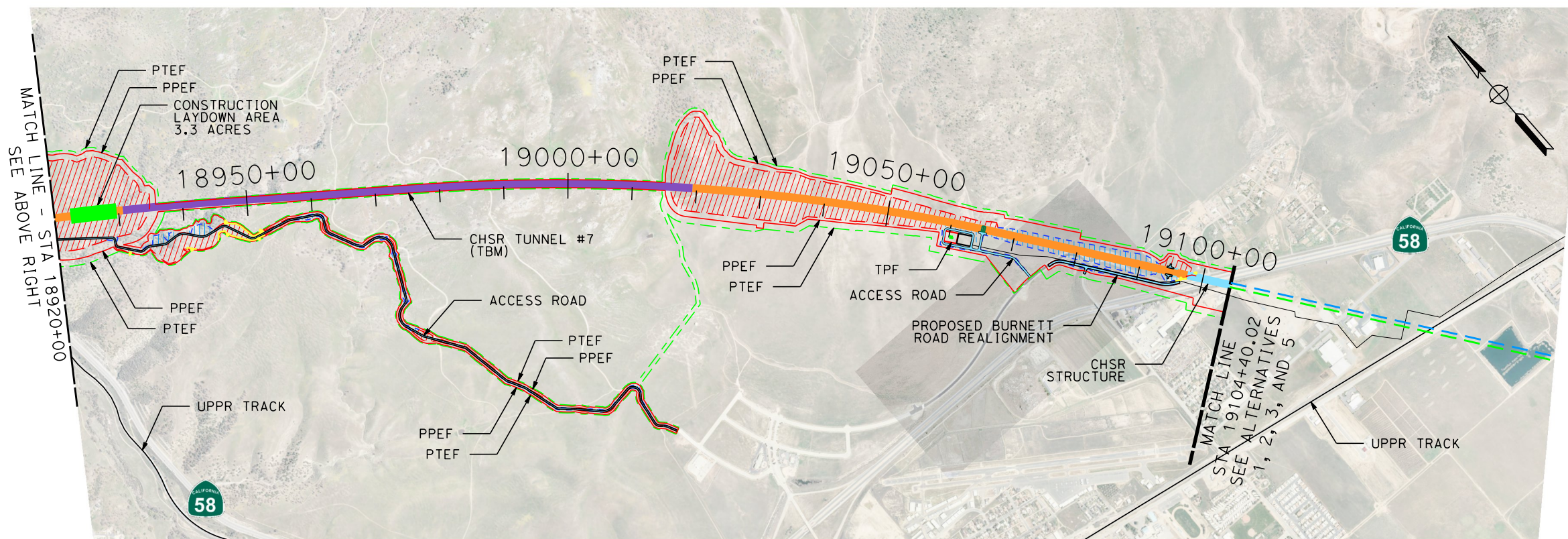

\$USER: 1/23/2020 2:43:41 AM \$PENTBL.S\$ \$PLTDRVS\$ \$FILE\$

REV	DATE	BY	CHK	APP	DESCRIPTION

DESIGNED BY
J. TURRELL
 DRAWN BY
B. MOZAFFARIAN
 CHECKED BY
S. LANDOLT
 IN CHARGE
G. CAMPBELL
 DATE
01/24/2020

**RECORD
PEPD
SUBMITTAL**

**NOT FOR
CONSTRUCTION**



CALIFORNIA HIGH-SPEED RAIL PROJECT
BAKERSFIELD TO PALMDALE
 REFINED CCNM DESIGN OPTION
 CONSTRUCTION SEQUENCING
 SHEET 2 OF 2

CONTRACT NO.
HSR13-44
 DRAWING NO.
CV-11202
 SCALE
AS SHOWN
 SHEET NO.